

User's Manual

LSC

Power Stand-Up Wheelchair



Where to find LifeStand

Contact us if you have any questions regarding servicing or sales in the area where you live.

For the United Kingdom

Permobil UK

Oceanic

Ground Floor

Navigation Business Park

Waters Meeting Road

Bolton

BL1 8SW

Tel. (+44) (0)1484 722 888

Fax (+44) (0)1484 723 013

E-mail: info@permobil.co.uk

For all other countries:

LifeStand France SAS

5 Rue Clément Ader

69740 Genas

France

Tel. : (+33) (0)4 37 26 27 28

Fax : (+33) (0)4 37 26 27 29

Email : info@permobil.fr

Produced and published by Permobil AB, Sweden

Edition no.: 2, 2014-02

Order no.: 205265-UK-0

Index

Important Information	4
Safety Instructions	6
Introduction	14
Operating Instructions	15
1. Adjusting and switching on	15
2. VR2 Control Panel	20
3. R-Net control panel LCD color display	24
4. Handling	30
5. Standing position and adjusting the seat back	32
6. Batteries and Maintenance	33
Accessories	38
Technical Specifications	39
Cabling Overview	40

Important Information about this User's Manual

We congratulate you on your choice of this Permobil LifeStand Stand-Up Wheelchair. Our goal is for you to continue to feel satisfied with your choice of both vendor and wheelchair.

Before you begin using your wheelchair, it is important that you read and understand the content of these operating instructions and in particular the Safety Instructions.

These operating instructions are primarily intended to acquaint you with the functions and characteristics of the wheelchair and how you can use them in the best manner possible. They also contain important safety and maintenance information, as well as describing possible problems that can arise while operating this wheelchair.

Always keep these operating instructions handy, since the need for important information can arise concerning its use, safety and maintenance.

It is also possible to obtain information concerning our products from our home page on the Internet. You can find us at www.permobil.com.

All information, pictures, illustrations and specifications are based upon the product information that was available at the time that these operating instructions were printed. Pictures and illustrations that are found in these operating instructions are representative examples and not intended to be exact depictions of the various parts of the wheelchair.

We reserve the right to make changes to the product without prior notice.

Ordering of Documentation

If you are in need of another copy of the User's Manual, it can be ordered from Permobil.

Technical support

In the event of technical problems, you should contact Permobil.

Always state the seats serial number when contacting Permobil to ensure that the correct information is provided.

Spare part & accessories

Spare parts and accessories must be ordered through Permobil.

Scrapping

Contact Permobil France for information about scrapping agreements in force.

Warranty

All wheelchairs are supplied with a two-year product guarantee. Batteries and charger are supplied with one year warranty.

Incident reporting

If an incident occurs please contact your nearest Permobil representative. Normally the same person you contacted at purchase day. To prepare this contact there is a link on our homepage, on the internet, at www.permobil.com. Open up your country page and the contact page. Here is the needed contact information and a guidance document in what information we need to investigate the incident. Complete the information as much as possible. This is of great help for us.

To increase the product quality and to ensure that our product is safe through the whole life cycle we need you to send in Incident Reports. It is also stated in MEDDEV 2.12-1 and Annex 9 that the manufacturer shall *“Encourage users or those given specific responsibility for reporting incidents that have occurred with medical devices and that meet the criteria within these guidelines to report the incidents to the Manufacturer and or to the Competent Authority in accordance with national guidance”*.

To meet the requirements and to ensure that our products shall remain safe in your hands we need your assistance. We hope you never need to use the information on this page but if there is an incident please contact us.

Product approval

This product fulfill the requirements according to EN 12184 and ISO 7176.

Safety Instructions

Stand-Up wheelchairs are a specialized device and special care must therefore be taken when it is used. Please read and follow all instructions and warnings in this manual before operating your LifeStand by Permobil Stand-Up wheelchair. Incorrect use may both injure the user and damage the chair. In order to reduce these risks, you should read the User's Manual carefully, in particular the safety instructions and their warning texts.

Throughout this manual the following symbol will be used to note items that have significant importance to safety concerns:

 **CAUTION!**

Please use caution where this symbol appears.

 **WARNING!**

Please use extreme caution where this warning symbol appears. Failure to observe warnings can lead to personal injury and property damage, including damage to the wheelchair.

Permobil is not responsible for personal injuries or property damage resulting from any person's failure to follow the warnings and instructions in this manual. Permobil is not responsible for injuries or damage resulting from failure to exercise good judgment.

The final selection and purchasing decision about the type of wheelchair to be used is the responsibility of the wheelchair user and his or her healthcare professional. Permobil Group. is not responsible for inappropriate selections of wheelchair models or features or improper fitting of the wheelchair.

Safety Instructions

Your wheelchair was configured specifically for your needs as prescribed by your healthcare provider. Consult your healthcare provider before changing the seat position or making any other adjustment. Some adjustments may reduce your wheelchair's performance or safety or may not be appropriate for your needs.

It is also of the utmost importance that you devote sufficient time to become acquainted with the stand-up function before you begin using it.

Do not undertake to stand up for the first time in the chair without making sure that you have assistance in the immediate vicinity if you should need help.

In order to make sure that nothing happened to the wheelchair while it was being shipped to you, you should check the following items before beginning to use it:

- that all products ordered are included in the delivery, including operating instructions and possible other documentation. If you suspect that something is missing, then contact your supplier or Permobil for more information as soon as possible.
- that no transport-related or other damages have occurred to the wheelchair and its accessories. If you discover that something has been damaged or in some other manner appears to be incorrect, then contact your supplier or Permobil for more information as soon as possible before you continue the checks.

Always be sure that tires are inflated properly before driving.

If you experience that the wheelchair in any manner is not behaving as expected or if you suspect that something is wrong: get in touch with your service contact or Permobil for more information.

Safety Instructions

CAUTION!

Operation

Do not let children operate the wheelchair without supervision. Do not operate the wheelchair on public streets or roadways. Obey all local pedestrian rules and be aware that vehicle drivers may have difficulty seeing you.

Do not operate your wheelchair under the influence of alcohol. Consumption of alcohol may impair your ability to operate your wheelchair safely.

Some physical limitations or use of medication, either prescribed or over-the-counter, may limit your ability to operate your wheelchair safely. Be sure to consult with your physician about your physical limitations and medications.

WARNING!

Modifications

Any unauthorized modifications to the wheelchair may increase the risk of personal injury and property damage, including damage to the wheelchair.

All modifications to the wheelchair must be performed by a qualified service technician authorized by Permobil to perform such service on Permobil products.

Weight Limitations

The maximum user weight for your LifeStand by Permobil is set forth in the specification section of the supplied User's Manual for this model. Operation of the wheelchair by users who exceed the maximum allowable user weight can lead to personal injury and damage to the wheelchair, as well as voiding any applicable warranty to the wheelchair.

Do not carry passengers on the wheelchair. Doing so can lead to personal injury and damage to the wheelchair.

WARNING!

Operation - Inclines

When propelling up an incline, be sure to drive your wheelchair straight up the incline (perpendicular). Driving at an angle up an incline increases the risk of tipping or falling.

Do not drive down or up a hazardous incline, such as a surface covered with snow, ice, or wet leaves or a surface that is uneven. Also avoid driving on ramps that do not have proper edge protection.

Safety Instructions



WARNING

Operation - Turning

Turning your wheelchair at high speeds can create the possibility of the wheelchair tipping and personal injury. The possibility of tipping can be increased by high turning speed, sharp turns, uneven surfaces, abrupt changes in direction, and driving from an area of low traction (e.g. lawn) to an area of high traction (e.g. sidewalk).

To protect against tipping, personal injury and property damage, reduce speed and reduce the sharpness of your turn when turning.

Overcoming steps or stairways

Whatever the obstacle, always approach slowly preferably assisted by a third person.

The front wheels can be elevated off of the ground by (the attendant) stepping on the Anti-Tip tube on the rear of the chair and simultaneously pulling back and down on the Push Handles. While it is not recommended that the chair be tipped back any further (the Anti-Tip wheels hitting the floor), it is possible. This would be done by rotating the Anti-Tip tubes to the up position (see page 19).

Make certain to return the Anti-Tips to the operating position when the operation is completed.

Going up and down a slope

Going up, always lean the trunk forward and avoid changing direction abruptly. Going down, always lean backwards. It is also important to keep speed and direction under control.

Make certain that the wheelchair is directed straight up or down the slope. Never attempt to traverse or make turns on a slope.

Safety Instructions



WARNING

Passengers

The wheelchair is not intended to transport passengers, regardless of the age of the passenger. The Maximum User Weight stated in the User's Manual for your seating includes the user and any personal effects. The Maximum limit should not be exceeded. The wheelchair's maneuverability and stability can be degraded as a result.

Environmental Conditions

Protect your wheelchair from exposure to any type of moisture, including rain, snow, or wash.

Do not operate your wheelchair in icy or slippery conditions. These conditions can lower the performance and safety of your wheelchair which could lead to an accident, personal injury and property damage, including damage to the wheelchair.



WARNING

Positioning Belt

Permobil positioning belts are designed to position the user only and will not protect you in an accident. You may even receive further injury from the belts.

Transfer into and out of the chair

Be sure that the wheel locks are engaged before entering or leaving the wheelchair and before pivoting the arm for transfer.

When transferring into or out of the wheelchair, every precaution should be taken to reduce the distance between the wheelchair and the place to which the user is transferring. Overextending this distance can cause user to overexert, lose balance, or fall.

Permobil recommends that users transfer in the presence of or with the assistance of an attendant.

Use caution when bending or reaching.

Do not use foot plates or armrests as supports when transferring into or out of the wheelchair. The footplates and armrests are not designed to be weight-bearing structures. Excessive force may cause them to give way, resulting in personal injury or property damage, including damage to the wheelchair.

Your doctor or therapist will advise you how to transfer according to your health and every day life.



Safety Instructions



WARNING

Transport

The wheelchair must be transported in or with transport solutions that have been approved for this purpose.

Check that the wheelchair is properly secured. A defectively fastened chair can cause serious injury to persons in the vehicle and serious damage to the vehicle.

Use Prohibited in Motor Vehicles

Permobil recommends that users NOT be transported in any kind of vehicle while in their wheelchair. The only safe alternative is that users be transferred into factory vehicle seating for transportation and use safety restraints made available by the auto industry. Permobil does not recommend any wheelchair transportation systems.

Never sit in your wheelchair while in a moving vehicle. In an accident or sudden stop you may be thrown from the chair and seriously injured or killed.

Permobil positioning belts are designed to position the user only and will not protect you in an accident. You may even receive further injury from the belts.



WARNING

Maintenance and Service

Carry out only the service and maintenance which are stated in the User's Manual. All other service and maintenance must be performed by a qualified service technician authorized by Permobil to perform such service on Permobil products

Do not use parts or accessories not authorized by Permobil. Use of unapproved "aftermarket" accessories and parts may cause changes in the wheelchair, which may make the wheelchair unstable or uncontrollable. Such use may also void the warranty on the wheelchair.

Damages/malfunctions on the wheelchair and its accessories

If you experience that the wheelchair in any manner is not behaving as expected or if you suspect that something is wrong: Stop operating as soon as possible and contact your service contact or Permobil for more information.

It's also of greatest importance that Permobil be informed if the wheelchair and its accessories have been subjected to transport damages, damages during driving or damages due to another cause as soon as possible after the event.

There exists a risk that the wheelchair and its accessories can no longer be used in a safe manner.

Introduction

Congratulations on the purchase of your new LifeStand Stand-up Wheelchair by Permobil!

You may have confidence in knowing that you have acquired the best in technology from the worldwide leader in mobility products.

Before operating your stand-up wheelchair, it is essential to read and carefully follow the below instructions and operating procedures.

Safety and maintenance:

1. Standing environment

The stand-up feature of this device must only be used on flat, obstacle free surfaces and away from stairs, ramps, slopes, uneven surfaces or inclines of any kind.

2. Adjustments

Adjustments made to a LifeStand stand-up wheelchair, as described in this document or otherwise, must be made by an authorized Permobil dealer. Under no circumstance should these adjustments be made by the end user or non-authorized personnel.

3. Maintenance

It is recommended that you complete a weekly and monthly inspection of your wheelchair. It is also recommended that it be serviced annually by an authorized Permobil dealer.

4. Benefits of a Daily Standing Regimen

The use of any stand-up device should be done only under the prescription and supervision of a medical professional. At the outset, it is recommended that your introduction to regular standing be closely monitored by your Physical or Occupational Therapist.

It has been documented that the regular and cyclical activity of going from the seated to the standing position may offer many benefits to those that are no longer able to stand on their own. The benefits are two fold: 1) there is the ability to once again function in daily activities that necessitate standing (reaching file cabinets and equipment in the workplace, accessing cupboards/stoves/shelving at home, as well as the ability to interact eye to eye); and, 2) the potential of physical benefits that result from repeated standing (these benefits may include improved; range of motion, bone density, circulation, bowel and bladder function, etc.).

Label:



Compliance of this device to annex I of the EU directive 93/42/EEC is confirmed by this CE label.

Operating Instructions

1. Adjusting your wheelchair

1.1 The footrest

Adjust the footrest so that the thigh is almost parallel to the base of the cushion

It is more comfortable if the FRONT of the thigh is slightly raised.

Do not raise it too far as it could cause excess pressure on the buttocks.

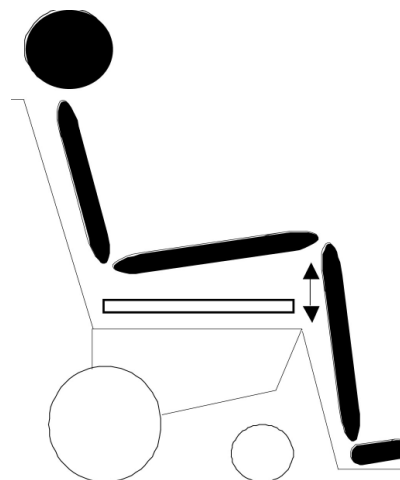

1.2 The tibia supports

1.2.1 : Adjusting the height and the inclination

Adjusting the height: The tibia supports can be adjusted to different heights. This adjustment can be made by unscrewing the bolt in the tibia supports. Ideally the greater part of the tibia support should be approximately 4 cm below the kneecap.

Adjusting the inclination: The holes in the tibia supports are fixed to the footrest cheeks by 2 screws. With the eccentric nut in the oblong hole and depending on the position of the eccentric nut, you can tilt the tibia supports (4 different positions).

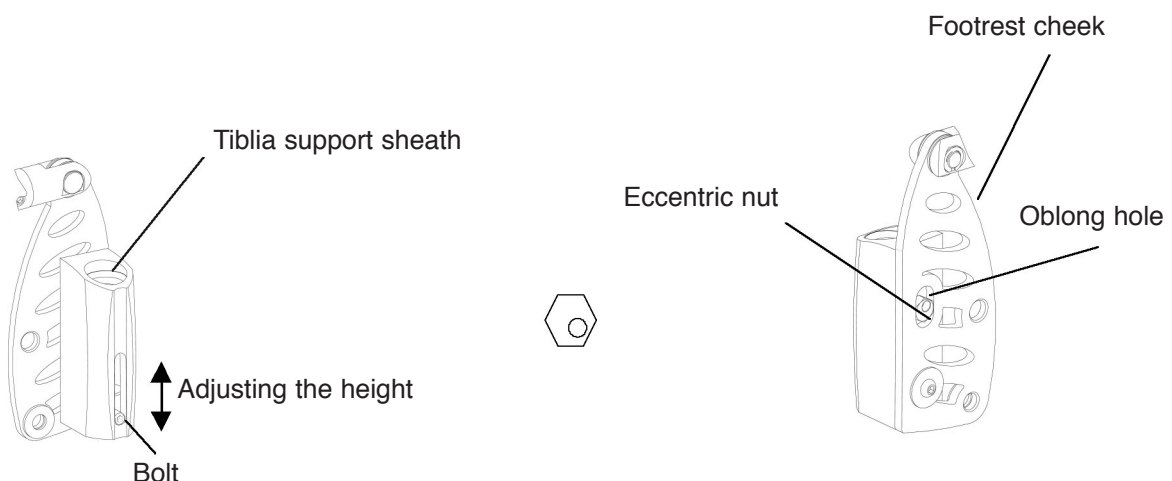

1.2.2 Adjusting the ergonomic kneepad

Each tibia support is made up of one middle stiff and adjustable frame (to be adapted to the patient's calf) with one extra pressure relief cushion.

1.2.3 To lock and release

To lock the system: put each tibia support in its own place, and swivel each one. The left side has to be placed first to bolt the right side in the hook. If you can see the green part of the button, this indicates that the support is correctly locked. The tibia supports **MUST** be correctly locked before standing up.

To release the supports: Press the red button. Swivel the right side. The left side has a passive safety system. To remove, lift it up nearly 2cm and then swivel towards the outside. Remove each side by lifting it.

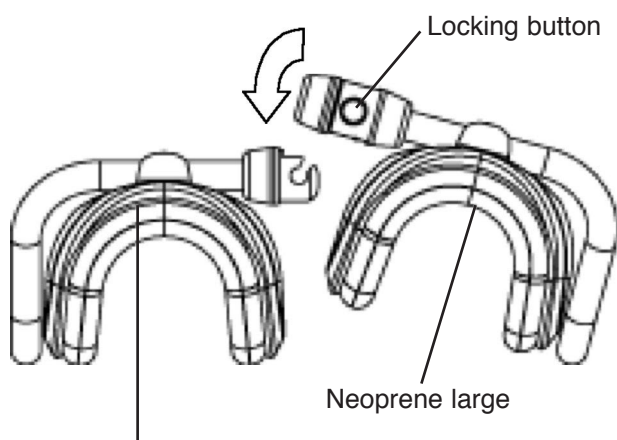

Middle stiff & adjustable tibia support

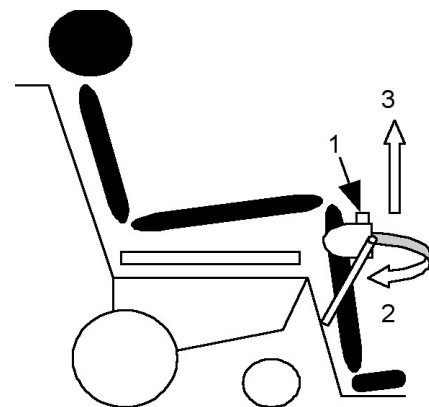

1.3: Armrests

1.3.1: Adjusting the armrest height.

The backrest bar has holes for adjusting the height of the armrest.

In standard position the top part of the backrest has three straps (20 cm/8"), while the bottom part has two (12 cm/4½").

If these 2 sets of straps are swapped around, the armrests can be raised from around 6 cm (2½ ") to 7 cm (3") as follows:

Lift the armrest cover;

Remove the straps;

Remove the armrest and backrest studs and replace them at the required height;

Replace the upper part (3 straps) with the lower part (2 straps) and vice versa;

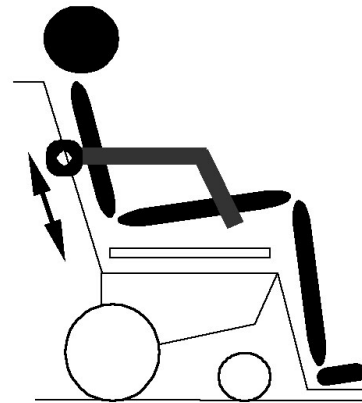

1.3.2 Adjusting the armrest depth

The depth of the armrests can be adjusted by +/- 8 cm (3").

To do this, turn the armrest over. Two hexagon socket screws allow the depth to be adjusted. Try the armrests in the "chest support" position. Slide the armrests until properly adjusted. Return them to the "armrest" position and tighten the screws.

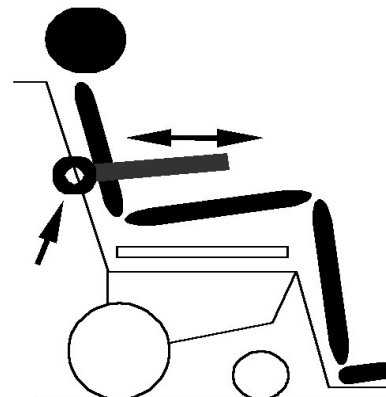

1.3.3 Putting the armrest in the safety position

Swivel the armrests ¼ turn inwards or ¾ of a turn outwards so that they become chest supports.

The armrests MUST be in the correct safety position across the chest BEFORE standing up.

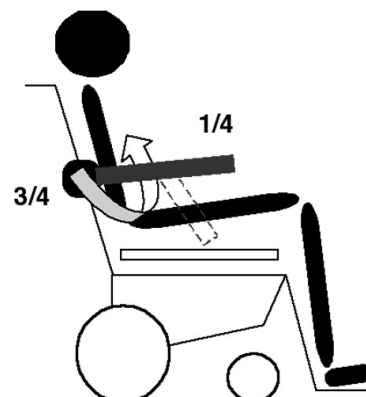

1.4 Adjusting the seat depth

1.4.1 Taking measurements

With the user seated, measure the thigh length (from the lower back to the front of the knee).
(Take care to maintain left/right symmetry).

Move the seat to the hole indicated in the following table.

Adjust the upper part first, then the lower part in the same way.

For example: if hole n° 1 is given for the upper part in the table, select hole n° 1 for the lower seat bar.

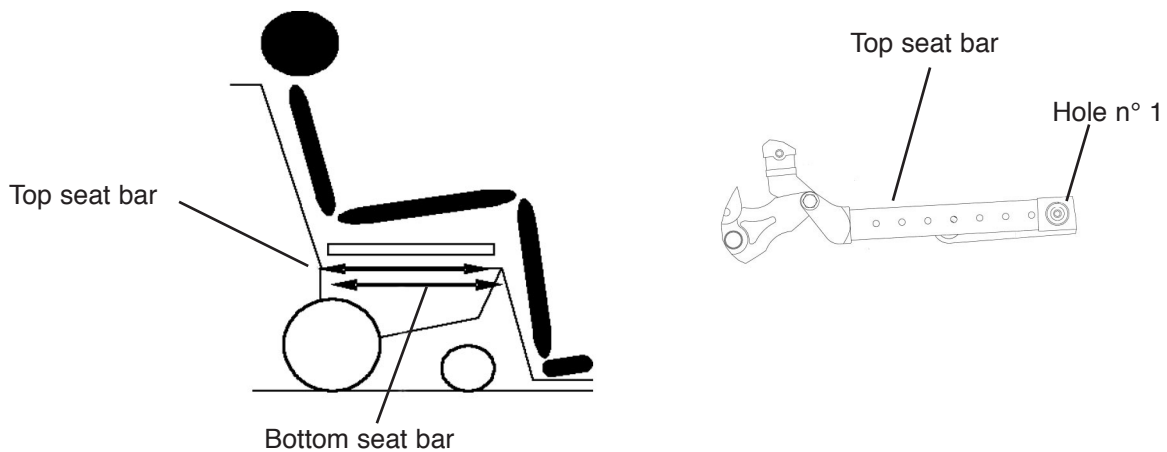

	Thigh length	Seat depth	Hole n°
Kid model	44	33	1
	46	35	2
	48	37	3
	50	39	4
Adult model	52	41	5
	54	43	6
	56*	45	7
	58	47	8
	60	49	9
	62	51	10
	64	53	11

(*) Standard : hole n°7

1.5 Checking the adjustments

Once the chair has been adjusted, the user should move to the standing position with the knees fully extended (refer to § Preparation for moving into the standing position).

The chair is properly adjusted if the line from the hips to ankles, passing through the knees, is perfectly straight. If it is not, the person should be seated once more and the adjustment fine-tuned by retracting first the seat/back assembly and then the tibia supports.

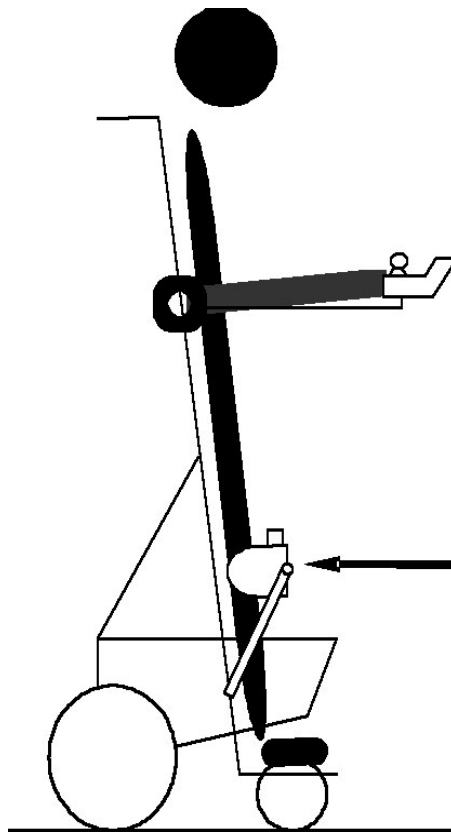

2. VR2 Control Panel

2.1 General

The VR2 Control Panel consists of a joystick, function buttons and indicator lights.

VR2 control panel overview



2.2 Charger Socket

This socket should only be used for charging the wheelchair. Do not connect any type of programming cable into this socket. This socket should not be used as a power supply for any other electrical device. Connection of other electrical devices may damage the control system or affect the E.M.C. performance of the wheelchair.

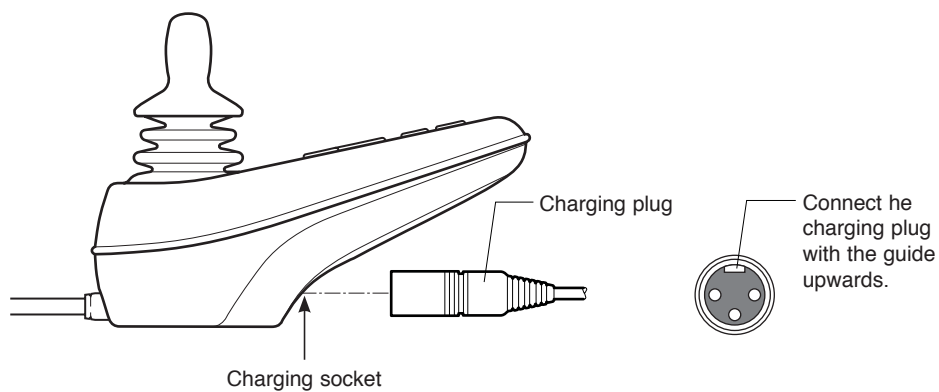

WARNING

The wheelchair's warranty will be voided if any device other than a battery charger supplied with the wheelchair, or the lock key is connected into the control panel's charger socket.

2.3 Function Buttons

On the control panel there are a total of 10 Function Buttons. The number of function buttons depends on the wheelchairs configuration.

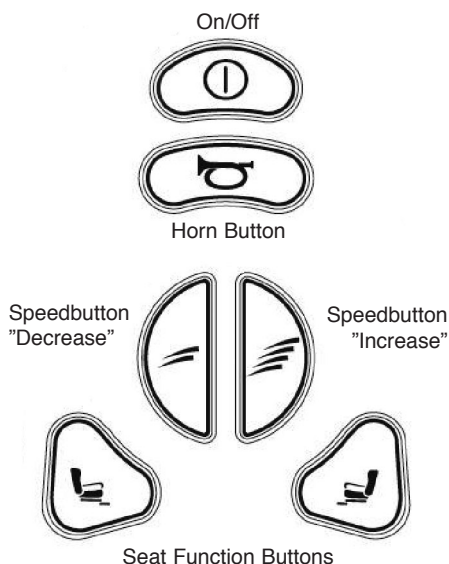

Power Switch, On/Off

Button to power up and power down the wheelchair. This button must have been pressed for the chair to operate.

WARNING

Do not use the Power Switch Button to stop the wheelchair unless there is an emergency. If you do, you may get thrown out of the chair or shorten the life of the wheelchair drive components.

Warning Horn

Press the button to sound the horn and attract attention.

Speed Buttons

These buttons decreases/increases the maximum speed setting. In special applications these buttons could allow the user to change profile of the control system.

Seat Function Buttons

If the wheelchair is fitted with seat actuators, this button will enter and exit actuator adjustment mode.

2.4 Battery Voltage Indicator

The battery voltage indicator lets you know how much charge is left in your batteries (from left to right):

Red+Yellow+Green	= Fully charged
Red+Yellow	= Half charged
Red	= Charge the batteries

The best way for you to use the indicator is to learn how it behaves as you drive your wheelchair. Like the fuel gauge in a car, it is not completely accurate, but will help you avoid running out of "fuel".

The indicator gives you a more accurate reading about a minute after you start driving the wheelchair.

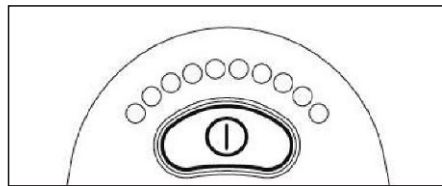

CAUTION

The voltage indicator also serves as a "fault indicator" for the wheelchair's electronic system.
* See page 82-83 for more information.

2.5 Speed display

Speed

Indicates the adjusted speed at which the wheelchair is set.

1 - 2 lamps	= Low speed
3 - 4 lamps	= Medium speed
5 lamps	= Maximum speed

Profile

In special applications the wheelchair can be programmed with more than one profile. In these cases, the display shows the selected profile.

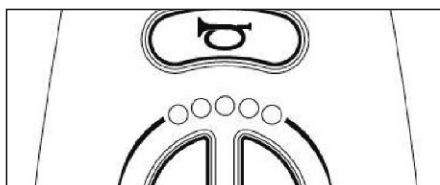

CAUTION

The speed display also serves as a "fault indicator" for the wheelchair's electronic system. *
See page 82-83 for more information

2.6 Locking/Unlocking the Wheelchair

The wheelchair can be locked to prevent unauthorized use.

Locking:

- Make sure the wheelchair is turned on. Press and hold the start up button for aprox. 1 sec. until a short "beep", release the button.
- Push the joystick forward until a short "beep", then push the joystick backwards until a short "beep".
- Release the joystick, a longer "beep" indicates that the wheelchair is locked.

Unlocking:

- Turn on the wheelchair, the speedindicator will riple back and forwards.
- Push the joystick forward until a short "beep", then push the joystick backwards until a short "beep".
- Release the joystick, a longer "beep" indicates that the wheelchair is unlocked.

2.7 Joystick

The joystick is used to regulate the speed of the wheelchair forwards or backwards, to turn and to brake.

The speed is regulated proportionally by moving the joystick forwards or backwards and the speed is directly proportional to the movement of the joystick (small movement low speed - large movement high speed).

The wheelchair is turned by moving the joystick to the left or right.

The wheelchair is braked by moving the joystick back to the neutral position or letting it go.

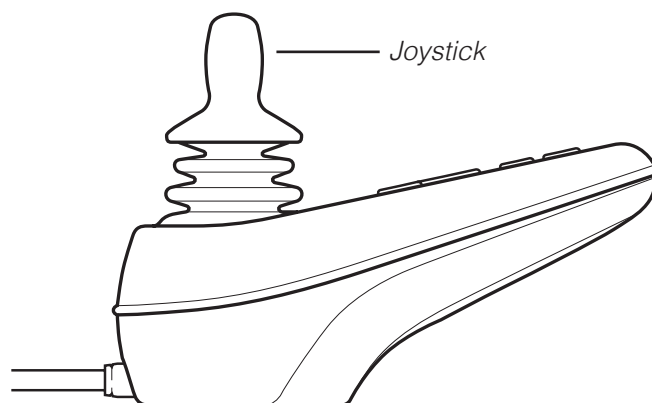

3. R-Net control panel LCD color display

3.1 General

The Control Panel consists of a joystick, function buttons and a display. At the front of the panel is the Charger Socket. Two Jack Sockets are located on the bottom of the panel.

Your wheelchair may also be equipped with a Seat Control Panel in addition to the control panel.

Control Panel Overview

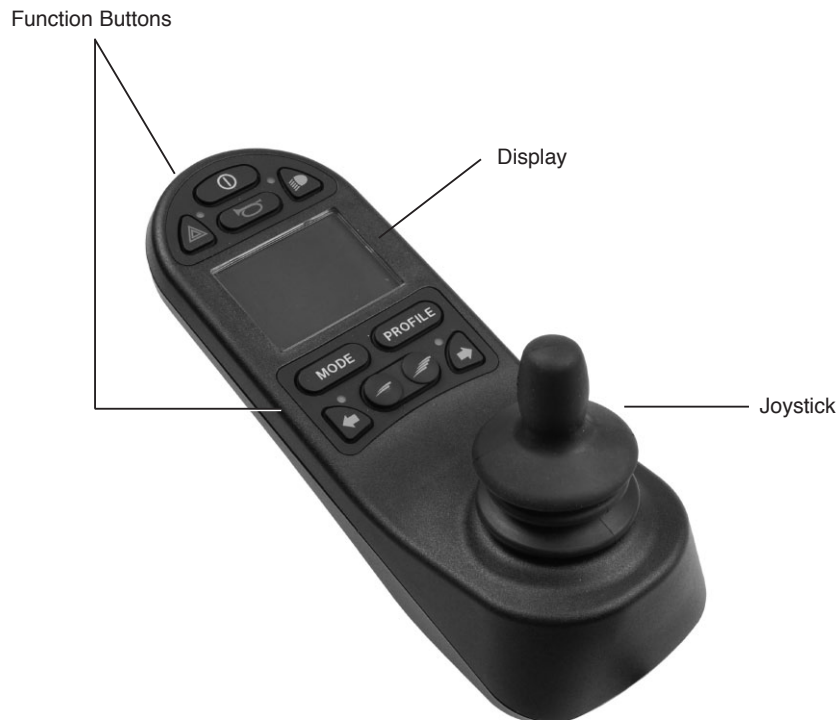

3.2 Function Buttons

On the control panel there are a total of 10 Function Buttons.

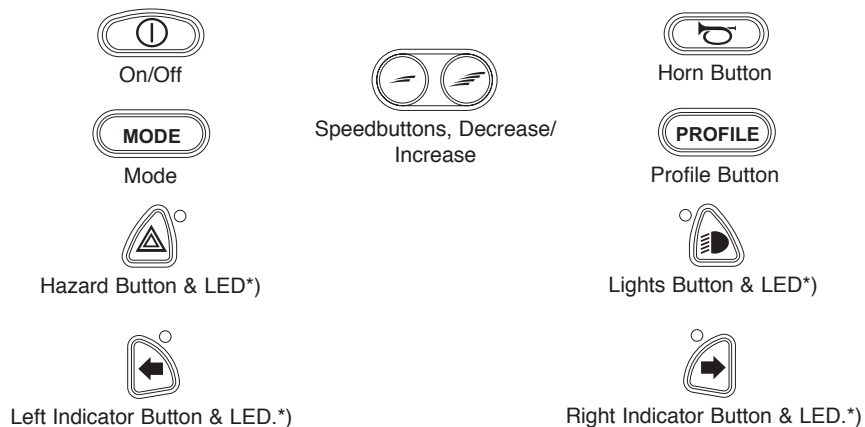

*) Only active if the wheelchair is equipped with lights.

On/Off Button

The On/Off button applies power to the control system electronics, which in turn supply power to the wheelchair's motors.

**WARNING**

Do not use the On/Off Button to stop the wheelchair unless there is an emergency. If you do, you may get thrown out of the chair or shorten the life of the wheelchair drive components.

Horn Button

The horn will sound while this button is depressed.

Maximum Speed Buttons

These buttons decrease/increase the wheelchairs maximum speed. Depending on the way the control system has been programmed a momentary screen may be displayed when these buttons are pressed.

Mode Button

The Mode button allows the user to navigate through the available operating Modes for the control system. The available modes are dependant on programming and the range of auxiliary output devices connected to the control system.

Profile Button

The profile button allows the user to navigate through the available Profiles for the control system. The number of available Profiles is dependant on how the control system is programmed. Depending on the way the control system has been programmed a momentary screen may be displayed when the button is pressed.

Hazard Warning Button and LED*

This button activates/deactivates the wheelchairs hazards lights. This function is used when the wheelchair is positioned in a way making it a obstruction for others. Push the button to activate the hazard lights and push it again to deactivate them. When activated the indicator LED will flash in sync with the wheelchair's indicators.

Lights Button and LED*

This button activates and deactivates the wheelchair's lights. Depress the button to turn the lights on and depress the button again to turn them off. When activated the lights LED will illuminate.

Left Indicator Button and LED*

This button activates and deactivates the wheelchair's left indicator. Depress the button to turn the indicator on and depress the button again to turn it off. When activated the left indicator LED will flash in sync with the wheelchair's indicator.

Right Indicator Button and LED*

This button activates and de-activates the wheelchair's right indicator. Depress the button to turn the indicator on and depress the button again to turn it off. When activated the right indicator LED will flash in sync with the wheelchair's indicator.

*Only active if the wheelchair is provided with lights.

3.3 Display

The status of the control system is shown in the display. The control system is on when the display is backlit.

Screen Symbols

The Drive screen for the R-net has common components, which will always appear, and components which will only appear under certain conditions. Below is a view of a typical Drive screen in Profile 1.

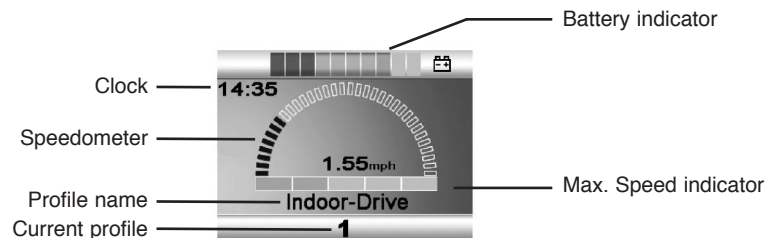

Battery Indicator

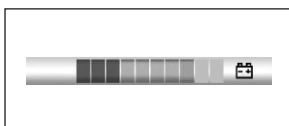

This displays the charge available in the battery and can be used to alert the user of the status of the battery.

Steady

This indicates that all is well.

Flashing Slowly

The control system is functioning correctly, but you should charge the battery as soon as possible.

Stepping Up

The wheelchair batteries are being charged. You will not be able to drive the wheelchair until the charger is disconnected and you have switched the control system off and on again.

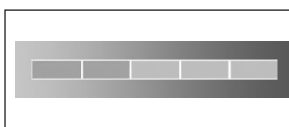

This displays the current speed setting.

The speed setting is adjusted using the Speed Buttons.

Current Profile

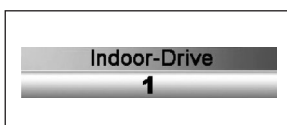

The Profile Number describes which Profile the control system is currently operating in. The Profile Text is the name or description of the Profile the control system is currently operating in.

In Focus

When the control system contains more than one method of direct control, such as a secondary Joystick Module or a Dual Attendant Module, then the Module that has control of the wheelchair will display the In Focus symbol.

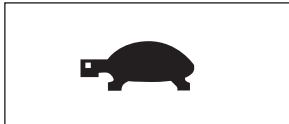
Speed Limit

If the speed of the wheelchair is being limited; for example, by a raised seat, then this symbol will be displayed. If the wheelchair is being inhibited from driving, then the symbol will flash.

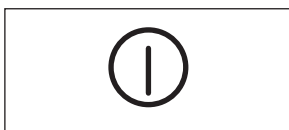
Restart

When the control system requires a restart; for example, after a module re-configuration, this symbol will be flashed.

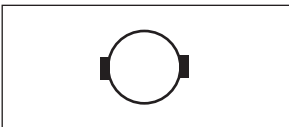

This symbol is displayed when the control system has intentionally reduced the power to the motors, in order to protect them against heat damage.

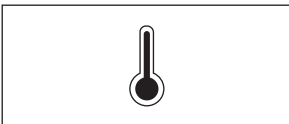
Control system Temperature

This symbol is displayed when the control system has intentionally reduced its own power, in order to protect itself against heat damage.

Timer

This symbol is displayed when the control system is changing between different states. An example would be entering into Programming Mode. The symbol is animated so that you can see the sand running through the hourglass.

E-Stop

If the control system is programmed for latched operation, then it is normal for an Emergency Stop Switch to be connected into the External Profile Switch Jack. If the Emergency Stop Switch is operated or disconnected, this symbol will flash.

3.4 Display Installation menu

The installation menu permits the user to set the clock, the display brightness, background color etc. Access the menu by holding down the keys for higher and lower maximum speed simultaneously. Scroll through the menu by moving the joystick up or down.

Exit the installation menu by first selecting "Exit" at the bottom of the menu and then moving the joystick to the right.

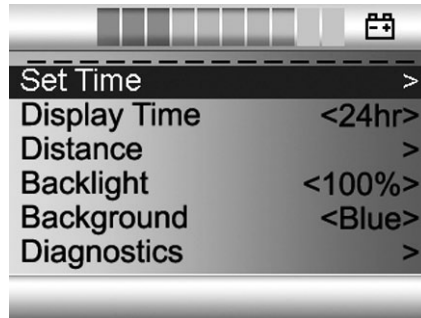

Setting the time (Set Time)

Select "Set Time" in the menu. Move the joystick to the right to go to the menu for setting the time. Then select "Year", "Month", "Date", "Hours" and "Minutes" by moving the joystick left or right. Set the desired value by moving the joystick up or down. Exit the installation menu by selecting "Exit" and then moving the joystick up or down.

Displaying the time (Display Time)

Select "Display Time" in the menu. Move the joystick right or left to select 12 or 24 hour display, or "Off" to remove the clock from the display.

Distance measurement (Distance)

Select "Distance" in the menu. Move the joystick to the right to go to the menu for setting distance measurement. Then select "Total distance", "Trip", "Distance display" or "Reset" by moving the joystick up or down.

- **Total distance** (Total Distance): Shows the total distance traveled by the control system.
- **Trip** (Trip Distance): Shows the total distance traveled since the last reset.
- **Distance display** (Display Distance): Selects Trip or Total Distance in the display.
- **Reset** (Clear trip distance): Move the joystick to the right to reset the Trip measurer.
- **Exit** (Exit): Move the joystick to the right to exit the installation menu.

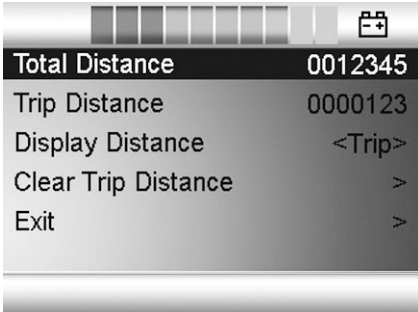

Option	Value
Total Distance	0012345
Trip Distance	0000123
Display Distance	<Trip>
Clear Trip Distance	>
Exit	>

Brightness (Backlight)

Select "Backlight" in the menu. Move the joystick to right or left to set the desired brightness for the display backlight. Ten fixed levels are available from 10-100%.

Background (Background)

Select "Background" in the menu. Move the joystick right or left to select "Blue", "White" or "Auto".

- **Blue** (Blue): The display background is blue in all profiles.
- **White** (White): The display background is white in all profiles.
- **Automatic** (Auto): The display background is programmed in the various travel profiles. E.g. blue background for slow profile for indoors travel and white background for rapid profile for outdoors travel.

Diagnostics (Diagnostics)

For qualified technicians only.

3.5 Maneuvering the seat

1. Press the "Mode" button one or more times until an icon for seat function appears in the control panel display - see illustration.
2. Move the joystick to the left or right to select a seat function. The icon for the seat function selected appears in the display.
3. Move the joystick forwards or backwards to activate the function.

Below is an example of the icons that may be shown in the display. Which icons are shown varies depending on the seat model and available functions.

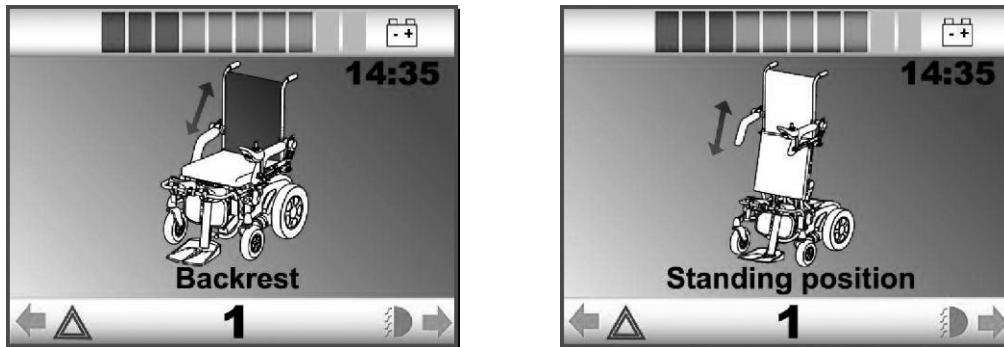

3.6 Joystick

The joystick is used to regulate the speed of the wheelchair forwards or backwards, to turn and to brake.

The speed is regulated proportionally by moving the joystick forwards or backwards and the speed is directly proportional to the movement of the joystick (small movement low speed - large movement high speed).

The wheelchair is turned by moving the joystick to the left or right.

The wheelchair is braked by moving the joystick back to the neutral position or letting it go.

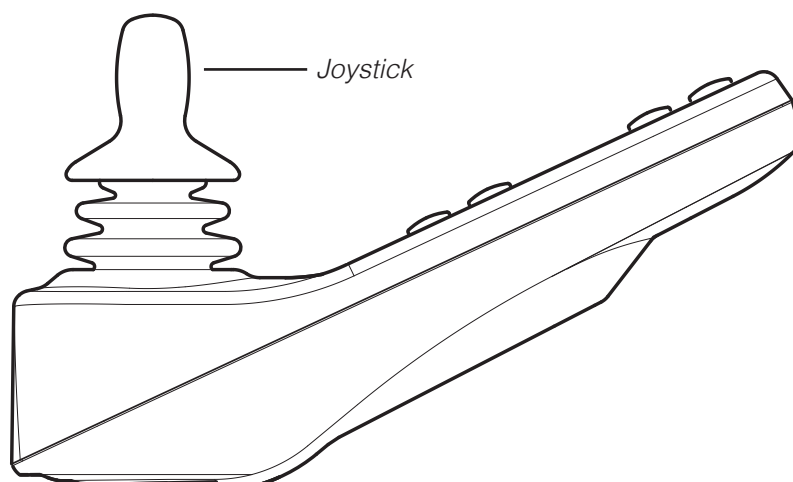

4. Handling

4.1 Disengage and engage the drive wheels.

The wheels of your wheelchair can be used in electrically powered mode or they can be switched into manual mode in order to enable a third person to move the wheelchair without using the motor.

The levers are located on each side at the rear of the wheelchair.

Disengage: Swing both levers outwards. The wheels are disengaged, the wheelchair can be pushed manually.

Engage: Swing both levers inwards. The wheels are connected to the propulsion engines controlled by the Joystick.

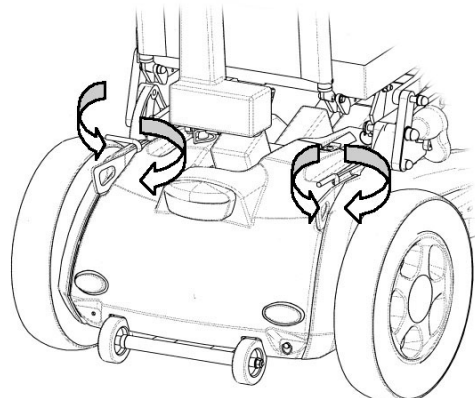

4.2 Driving your chair

The direction of the chair depends on the direction given to the joystick.

Push forward: The wheelchair drives straight forward.

Push to the right: The wheelchair drives to the right.

Push left: The wheelchair drives to the left.

Push backwards: The wheelchair will drive straight backwards.

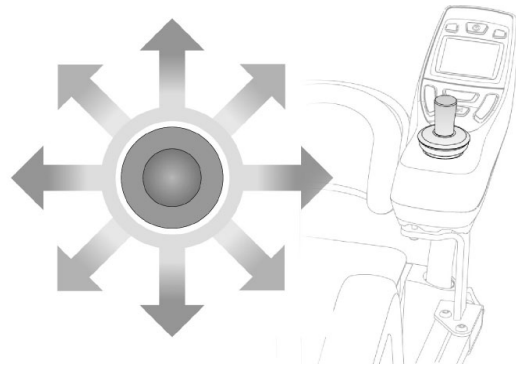

WARNING

The electromagnetic brakes are only effective on slopes of less than 10 %.

4.3 Braking

The system automatically returns to the neutral position when you let go of the joystick. The motor brake operates and stops the chair immediately. In the parking position, the wheels are automatically locked by the electromagnetic brakes.

For an emergency stop, reverse the direction of the joystick control beyond the NEUTRAL position.

5. Standing position and adjusting the seat back

5.1 The standing position

5.1.1 Preparation for moving to the standing position:

Make sure that the chair is on a flat level surface. For obvious safety reasons you must on no account move into the standing position on a slope or if you are anywhere near a definite change of level (example: stairs, ramps, etc.). Put the backrest in the vertical position.

- a) Lock the tibia supports.
- b) Put the armrest in the safety position.

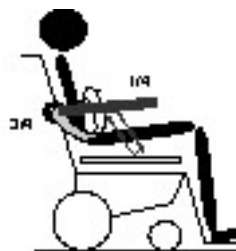

5.1.2 Moving in the standing position and back recline:



WARNING

On both modes, electrically powered or free wheel mode, there is the possibility to come into the standing position. However, if you are on the freewheel mode, we advise you to put ON both brakes before standing up.

R-net Control System: The "Mode" button enables to switch into the actuator-mode where you can choose between 2 electric seat functions (back rest recline & standing position). On the display, the blinking part of the wheelchair diagram display indicates the activated function.

With the joystick, you can select by a lateral pressure (to the left, to the right) the icon "back recline" or "standing position".

VR2 Control System: Press the left "Seat Function" button to activate the "standing up mode". Press the right "Seat Function" button to activate the "back rest recline mode".

Once selected, "the standing position" or "the back recline" is activated by moving the joystick forwards and backwards.

In order to stop the process, release the joystick. There is the possibility to stop in any position in between.



CAUTION

Always think about putting the seat back in its vertical position before coming into standing. Once selected, the standing position or the adjusting of the seat is activated by moving the joystick upwards and downwards.

In case of contractures in moving to the standing up position, move slowly and carefully. In order to stop the process, release the joystick. There is the possibility to stop in any position in between.

5.1.3: Driving in the standing position

After or during a phase in the standing position, if your wheelchair is on the electrically powered mode, it is possible to activate "drive-mode":

R-net Control System: Press the "Mode" button to switch into "drive-mode".

VR2 Control System: Press the activated "seat function button" to switch into "drive-mode".

However, activating this mode in the standing position will switch on a security device SPEED/LIMIT which limits the speed to between 30% to 60% of the maximum speed obtained in the sitting position. (forwards: between 1.8 and 3.6 km/h maxi – backwards: between 1.3 and 2.2 km/h maximum).

WARNING

The security device can be put on mode SPEED/STOP. In this case moving in the standing or in between position is made impossible (contact your specialist dealer).

CAUTION

For safety reasons, while driving in the standing position: move the joystick gently and do not jerk; avoid crossing obstacles; never drive on a slope. Do not attempt to move, or be moved, standing in freewheel mode.

6. Batteries and Maintenance

6.1 The batteries

6.1.1 Characteristics of the Batteries

Your wheelchair is equipped with sealed, maintenance free TRACTION batteries that are conform to the air transport standards DOT and IATA.

These batteries have been developed especially for traction of electric wheelchairs:

- « Traction » means that they are able to provide saved energy over a long period of time, compared to starter batteries which provide a high quantity of energy for only a few minutes.
- « Sealed » means proper, but also that there is no risk of acid coming out of the battery during charge or in case the wheelchair is turned over or fell over. There is no evaporation during the charging process.
- « Maintenance free » means that it is not necessary to monitor the level of the battery:

The only precaution to take is to mind a proper discharge and charge. From those two operations depends the durability of your batteries and the autonomy of your wheelchair.

CAUTION

The use of acid batteries is absolutely prohibited with this wheelchair.

6.1.2 Use and Charge of the Batteries

The traction of your chair is assured by 4 batteries. The durability of the batteries depends on several factors:

1. The product quality:

Use only original batteries that conform to the technical specifications of the manufacturer.

The use of batteries of inferior quality may cause damage on the electronics or derange the functioning.

2. Your use of the batteries: the quality of discharge.

The discharge indicator on your controller provides you with valuable information.

ATTENTION: driving long time with the discharge indicator in the red results in deep discharge that damages non-reversibly the durability of the batteries.

3. The number of charging cycles: charge sensibly.







The durability of the traction batteries depends partly on the number of cycles « discharge/charge » but also on the level of every discharge.

Thus a battery discharged 100% is limited to a number of 200 cycles, while the same battery discharged to only 75% has a number of 275 cycles and still the same battery discharged to only 50% has an even higher number of 450 cycles.

This displays the charge available in the battery and can be used to alert the user to the status of the battery.

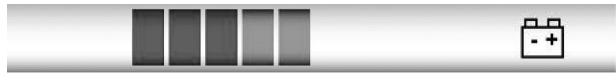
You will not be able to drive the wheelchair until the charger is disconnected and you have switched the control system off and on again.

See battery chapter in the first part for more information.

Battery Gauge	Meaning
	Battery full
	Battery almost full
	Battery half full, drive towards a charger
	Battery low, recharge soon
	Battery almost empty, recharge now
	Battery empty, recharge immediately

Good to know:

The autonomy of your wheelchair is now about 10 to 15 minutes before it completely stops. Thus it's time to conduct a complete charge.

4. Complete charge

A complete charge is long (between 10 and 12 hours), but efficient.

An incomplete charge will also reduce the durability of your batteries by one charging cycle. The battery will not have enough time to store the energy correctly. It will not be able to reconstitute the missing energy. The autonomy will be reduced. A series of incomplete charges will have an even more disastrous effect. In fact, the different batteries that are charged incomplete and unbalanced between each other, will cause a reduced durability of the whole set of 4 batteries.

Conclusion: To maintain a maximum autonomy and optimise the durability of your batteries, every started charging cycle has to be completed. Repeated short or incomplete cycles limit progressively the capacity of your batteries.

5. Long term storing of the wheelchair without using it

The batteries discharge by themselves naturally and loose continuously their capacity. In case the chair isn't being used for a long period of time, it is recommended to charge it at least once a month to maintain a complete level of charge.

Good to know: New batteries need a start-up time of 15 to 20 charging cycles before they reach their full capacity.

6.1.3 Use of the charger

Use only the charger provided with the wheelchair. It's adapted to the batteries of your vehicle. This charger adapts to all voltages in between 110 and 240 Volts.

It initiates a programmed charge phase and disconnects automatically in the end of the cycle to prevent damage of the batteries.

The charger has to be placed on a plane surface and protected from humidity.

For your own security it is imperatively necessary to read and respect the following orders before using the charger

1. Before charging the batteries, switch off the wheelchair.
2. Connect the charging cable to the wheelchair, than connect the charger to the power socket.
3. Once the charge is terminated, unplug the power socket first, than disconnect the charging cable.

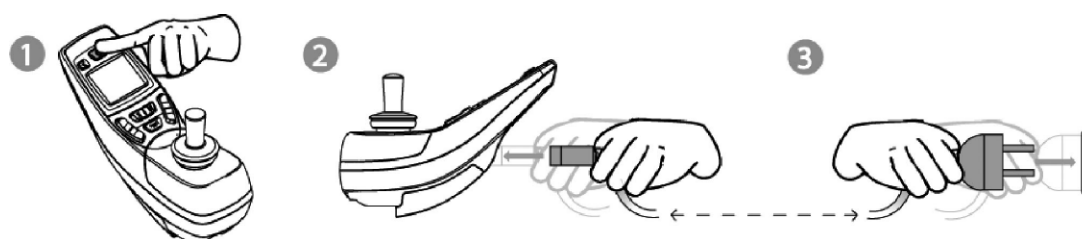

Disconnection

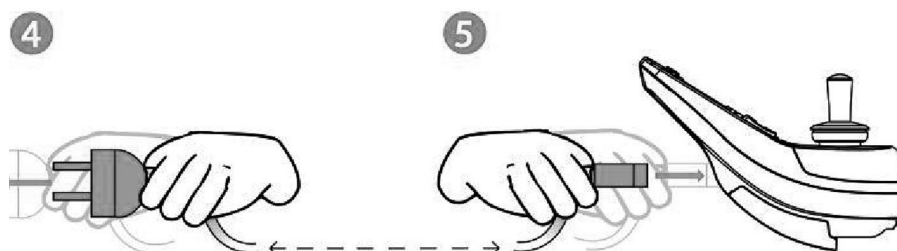

6.1.4 Autonomy of the wheelchair

The autonomy of your wheelchair on flat ground is about 25 km at nominal operation. This autonomy is subject to the influence of various factors. In practice the road condition, inclinations, driving mode, use of lights, tire pressure, total transported weight, outside temperature, etc. are some of the elements to be considered.

The way the batteries are charged has a considerable influence on the energy consumption and thus affects the rapidity of discharge.

Attention: at 10 km/h, a distance of 25 km is overcome in about two hours.

When driving outdoors it is recommended to assure that a sufficient amount of energy is available to return to the point of departure.

WARNING!

This product has been supplied by an environment-friendly manufacturer in compliance with the EC directive (WEEE 2002/96/CE) concerning processing of electrical and electronic equipment. This product may contain substances which are harmful to the environment if you dump them in places inappropriate to their disposal according to law. The wastebin interdict logo is posted on this product to encourage you to recycle whenever possible. Safeguard the environment by recycling this product in a recycling centre at the end of its lifespan.



6.2 Batteries

The space required for carrying the chair in a vehicle can be greatly reduced by:

- a) Removing the tibia supports and folding the footrest.
- b) Folding the backrest down.
- c) Removing the control unit from the wheelchair.

CAUTION

Except specially equipped vehicle, your wheelchair has neither been designed nor tested to be used as a seat in a vehicle. We recommend you to use an ordinary car seat and to use fixings in the car.

After each reassembly of the wheelchair, before use, it is imperative to check if every part is locked in position properly.

6.3 Maintenance

6.3.1 Cleaning

Painted sections and hoods: use only soap and water. Protect electrical connections and motors from possible splashing by water.

Upholstery: dry-clean regularly. We would advise you to clean before the first use.

Control unit may be cleaned with a damp (not wet) rag. Use regular household cleaners in diluted water, never petroleum, ether or the like.

6.3.2 Service manual

For your safety there should be a maintenance check of the main components of the wheelchair every year. To this purpose we supply you with a maintenance record in order to conduct the servicing. We would advise you to have this manual filled in after each checkup in order to carry out an effective followup of the different operations.

6.3.3 Diagnosis Codes on display

The primary objective of this chapter is to assist service personnel in finding the likely area of a detected trip within the whole wheelchair electrical system. It is important to realize that even though the control system is signalling a trip, it may not be the control system itself that is defective. This is because the control system is able to detect problems in other electrical components (motors, batteries, solenoid brakes, etc.) or, more importantly, the wiring to them. When a control system has detected a trip, a system trip is indicated.



WARNING!

After checking the error, consult your retailer for customer service. Don't try to repair your wheelchair without the help of a technician.

Flash code or text code	Description	Cause/Action
Joystick error	Joystick fault	Cause/Action Ensure that the joystick is centered
Joystick calibration error	Joystick Calibration process has not been successful.	Enter OBP and attempt calibration
Module error	Power module fault	Check all cables and connections. Cycle the power.
3B00	Left motor error (M1)	Check the motors, cables and connections to the control system.
3C00	Right motor error (M2)	Check the motors, cables and connections to the control system.
1505	Left brake error	Check the solenoid, cables and connections to the control system.
1506	Right brake error	Check the solenoid, cables and connections to the control system.
Low battery	Low battery	Check The condition of the batteries and the connections to the control system.
High battery	High battery voltage	Check the condition of the batteries and the connections to the control system.
7205 / 7206 / 7207	Left Light error	Check the indicator and the lights, cables and connections to the control system
7209 / 720A / 7208	Right light error	Check the indicator and the lights, cables and connections to the control system
Overtemp (acts)	Overtemp of the actuator	Allow the power module to cool. If the power module is frequently overheating, check the condition of all the actuator motors and the connections of them.
Overtemp (lamps)	Overtemp of the lights	Allow the lights module to cool. If the lights module is frequently overheating, check the condition of all the connected bulbs and lights.
Over- current	Excessive amount of current in an actuator.	Check the movement of the actuator is not obstructed. Check the endstop switches are terminating the power to the actuator motor.
Other error	Memory error, module error, bad settings, system error, inhibit active...	Check all cables and connections and cycle the power. Consult your retailer.

6.3.4 Stand-up mechanism problem

Should a problem arise regarding the stand-up mechanism i.e. if the chair is stuck in stand or semi-stand position : it is equipped for this eventuality with a safety system located under the rear bonnet to enable a return to the sitting position.

The procedure is as follows:

- remove the rear plastic bonnet.
- unplug the jack from the stand-up gas cylinder.
- plug the jack into the jack socket which forms one piece with the right-hand battery tray.
- the gas cylinder automatically initiates a slow descent into the sitting position.
- once the position is reached, unplug the jack and contact your distributor.
- if this procedure does not work, contact your specialised dealer.

Technical Specifications

Chassis	Rigid, made from treated steel and aluminium with epoxy resin paint
Seat	Depth adjustable with cushion
Back	Rest electrically adjustable
Upholstery	Fire-resistant (M3), washable fabric
Arm rests	Retractable, can be converted to adjustable chest supports
Foot-rests	Height can be adjusted
Wheels	Front 200 x 50 (8 ") Rear 350 (3.00 / 8 ")
Brakes	Manual by pushing and electromagnetic in the wheels
Tibia supports	Adjustable in height, in inclination and in width
Propulsion	Electric
Rear stabilisation	By two anti-tip rollers with variable symmetry
Range	approximately 25 km
Maximum speed	7 km/h
User 's maximum weight	120 kg
Maximum gradient	9% with 80 kg load / 6 % with 120 kg load
Batteries	: 4 x 12 Volt / 18 Ah
Charging voltage	24 Volts
Operating temperature	ambient temperature range (approx.-15 °C / +45 °C)

Weight of parts

Batteries	16 kg per pair
Charger	1 kg
Control unit	0.4 kg

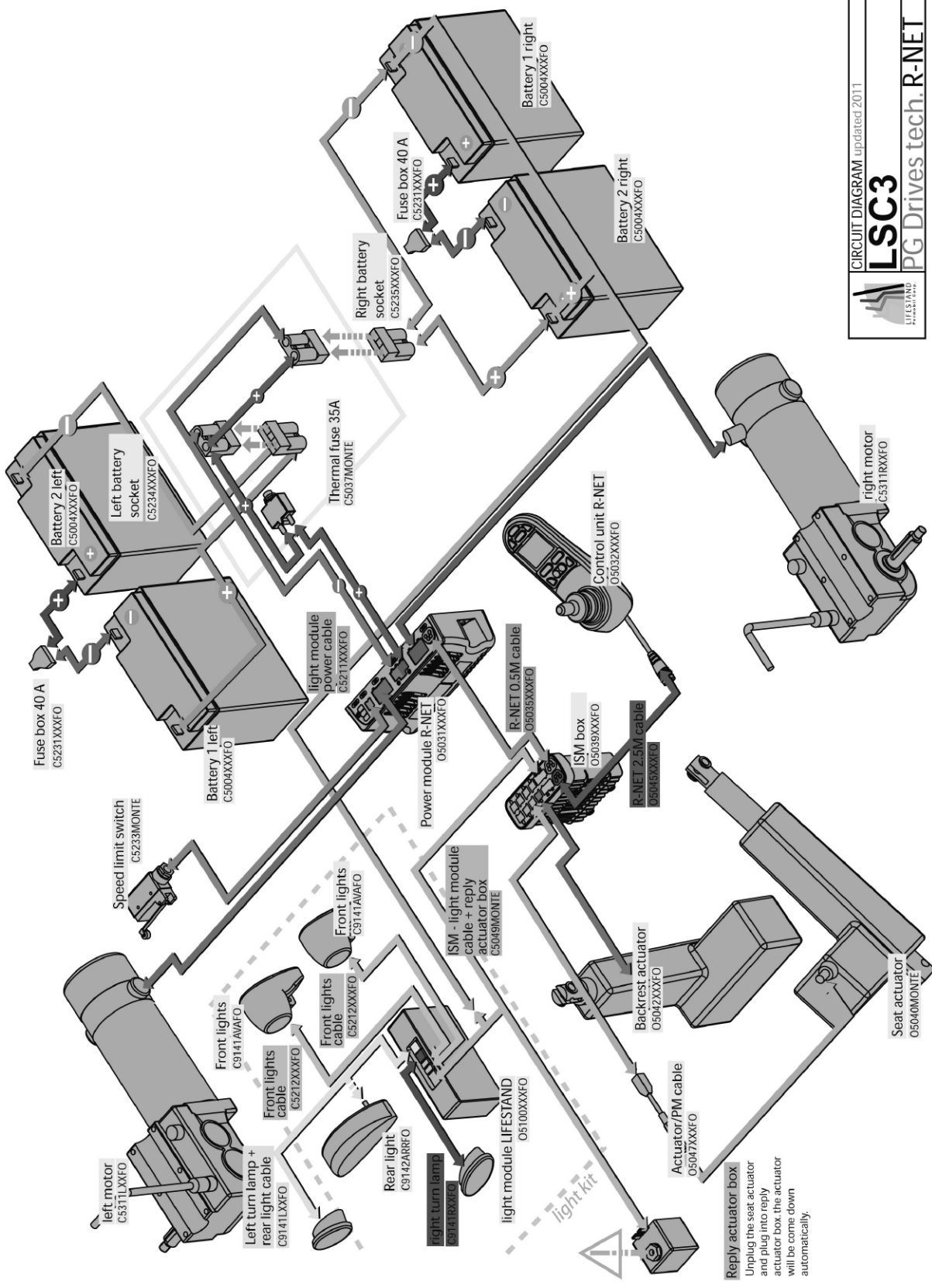

CIRCUIT DIAGRAM updated 2011

LSC3

PG Drives tech. R-NET

LIFESLAND
Produced in Italy

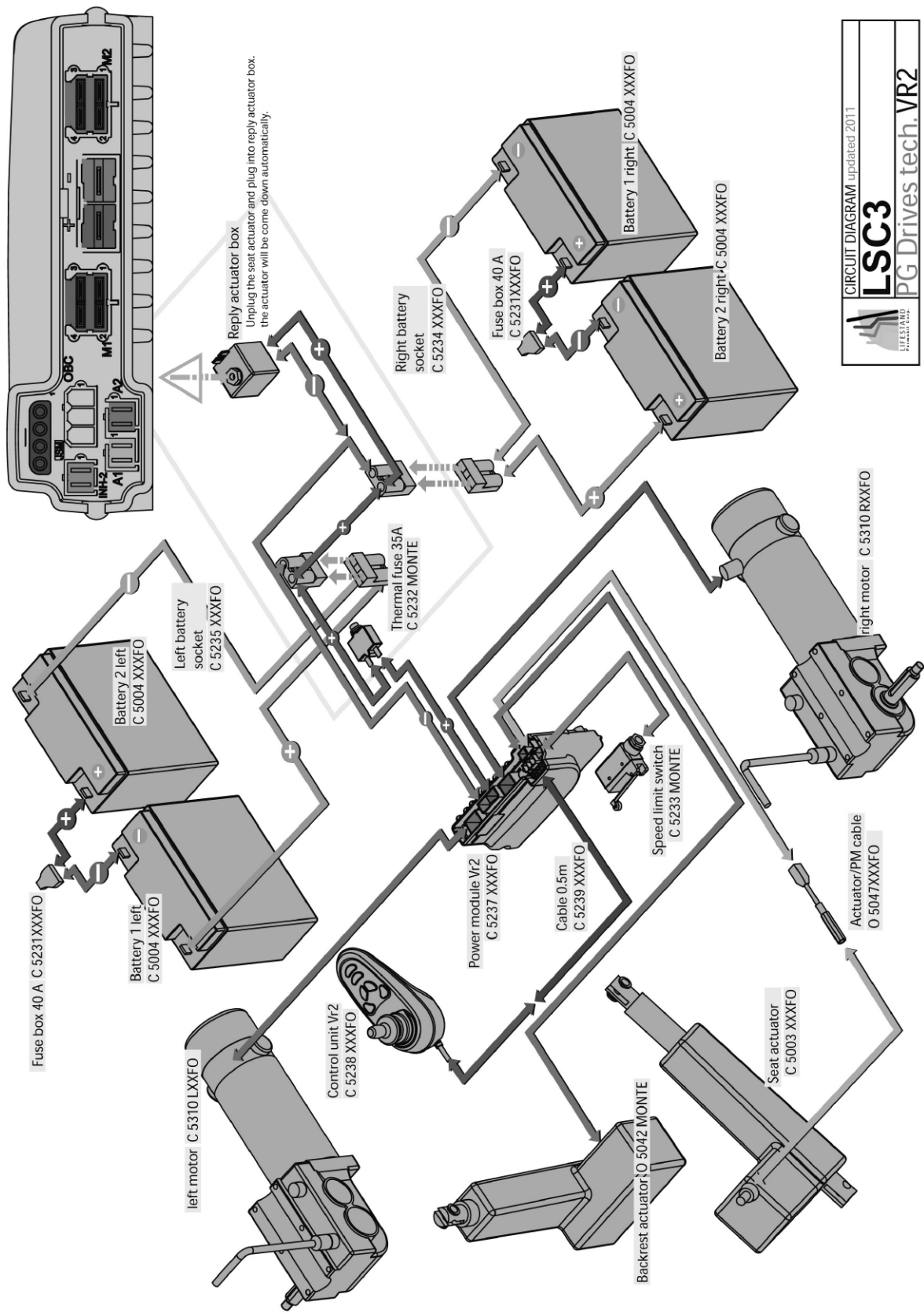



Order no.: 205265-UK-0