

# LEVO *combi* & *combi JR*

## INSTRUCTION- and SERVICE MANUAL



**Please read the Instruction Manual carefully  
before attempting to use your wheelchair  
The Service Manual is provided for the use of  
Agents and Authorized Repairers  
Alterations in constructional and technical manner  
or to the electronic require the written authorisation  
of LEVO AG, otherwise no warranty or product  
liability will be accepted.**

**In case of difficulty contact:**

Manufacturer:

Agent:

LEVO AG  
Anglikerstrasse 20  
CH-5610 Wohlen  
Tel:+41 (0)56 618 44 11  
Fax:+41 (0)56 618 44 10  
Internet: <http://www.levo.ch>



# Contents

<b>INSTRUCTION MANUAL</b> .....	5
<b>Possible positions</b> .....	6
<b>Declaration of Conformity</b> .....	9
<b>Seating and Standing Assessment</b> .....	10
<b>1. Introduction</b> .....	12
<b>2. Warranty</b> .....	13
<b>3. Delivery</b> .....	13
3.1. Despatch and transportation.....	13
3.2. Delivery.....	13
3.3. Storage.....	14
<b>4. Accessories</b> .....	14
<b>5. Warning</b> .....	14
<b>6. Preparing the wheelchair for use and operation</b> .....	15
6.1. LEVO combi standard backrest.....	15
6.2. V-Trak backrest system (optional).....	16
6.3. Further preparations.....	16
<b>7. First adjustments</b> .....	16
7.1. Seat depth.....	16
7.2. Seat cushion.....	18
7.3. Footplate.....	18
7.4. Armrest.....	19
7.5. Low shearing at the back.....	20
7.6. Backrest assembly of the LEVO <i>combi</i> standard backrest.....	21
7.7. V-Trak backrest system (option).....	21
<b>8. Safety harness</b> .....	23
8.1. Knee support.....	23
8.2. Chest strap.....	23
<b>9. Using the LEVO combi</b> .....	24
9.1. Getting into the wheelchair.....	24
9.2. Getting out of the wheelchair.....	24
9.3. Sideways transfer.....	25
9.4. Skirt guards.....	25
<b>10. The safety cut-out</b> .....	26
<b>11. Joystick module</b> .....	27
11.1. Security key.....	28
11.2. On / Off switch.....	28
11.3. Battery indicator.....	28
11.4. Joystick.....	28
11.5. Speed selection.....	28
11.6. Mode functions.....	29
11.7. Lighting installation.....	32
11.8. Horn.....	33

<b>12. Electromagnetic interference (EMI)</b> .....	33
<b>13. Driving the wheelchair</b> .....	34
<b>14. Motor solenoid brakes</b> .....	36
<b>15. Free wheel device / Motor disengaging lever</b> .....	37
<b>16. Batteries</b> .....	37
16.1. Charging the batteries.....	37
<b>17. Attendant instructions</b> .....	38
17.1. Motor brakes .....	38
17.2. Lifting & general safety .....	38
17.3. General safety.....	39
<b>18. Cleaning</b> .....	39
<b>19. Maintenance</b> .....	39
19.1. Motor brakes .....	39
19.2. Spare parts .....	39
<b>20. Transporting your wheelchair</b> .....	39
<b>21. Disposal</b> .....	40
<b>22. Trouble shooting</b> .....	40
<b>23. Controller self help guide</b> .....	41
<b>24. Technical information</b> .....	42

<b>SERVICE MANUAL</b> .....	43
<b>1. Introduction</b> .....	44
<b>2. Health &amp; safety</b> .....	44
<b>3. Adjustments</b> .....	44
3.1. Seat depth .....	44
3.2. Low shearing at the back.....	44
3.3. Adjustment of the backrest.....	44
3.4. Electronic control system .....	44
<b>4. Repairs: general instructions</b> .....	45
<b>5. Tools &amp; torque settings</b> .....	45
<b>6. Important points</b> .....	46
<b>7. Recommended safety checks</b> .....	46
<b>8. Repairs</b> .....	48
8.1. Replacing the drive wheels .....	48
8.2. Replacing the tire of a drive wheel.....	48
8.3. Replacing the front wheels .....	49
8.4. Replacing the back wheel.....	49
8.5. Replacing the wheel fork (at front and back).....	50
8.6. Replacing the connector of the back low shearing system.....	50
8.7. Replacing the motor disengaging cable (free wheel device).....	51
8.8. Replacing the driving motor.....	52
8.9. Replacing the batteries .....	52
8.10. Replacing the joystick module .....	53
8.11. Replacing the power module.....	53
8.12. Replacing the ALM (Actuator-Lights-Module).....	54
8.13. Replacing the gas spring .....	54
8.14. Replacing the actuator "standing" .....	55
8.15. Replacing the actuator "lift" .....	55
8.16. Replacing the actuator "lying" .....	56
8.17. Replacing the safety cut-out.....	56
8.18. Replacing bulbs .....	57
8.19. Replacing the light (front, white) .....	58
8.20. Replacing the indicator.....	58
<b>9. Testing the wheelchair</b> .....	59
<b>10. Cleaning</b> .....	59
<b>11. Technical information</b> .....	60
11.1. Measurements (metric).....	60
11.2. Measurements (imperial).....	61
11.3. General technical information .....	62
11.4. Electromagnetic Interference (EMI) .....	63

**LEVO** *combi & combi JR*

**INSTRUCTIONMANUAL**

**Please read these instructions carefully  
before attempting to use your wheelchair**

## Possible positions

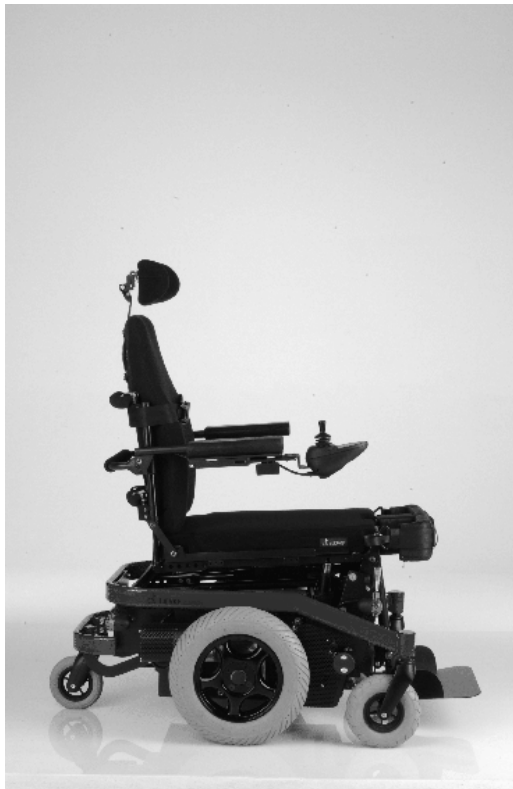

**LEVO combi**  
Seating position (standard)



**LEVO combi**  
Seating position  
plus lift (option)



**LEVO combi**  
Standing position (standard)

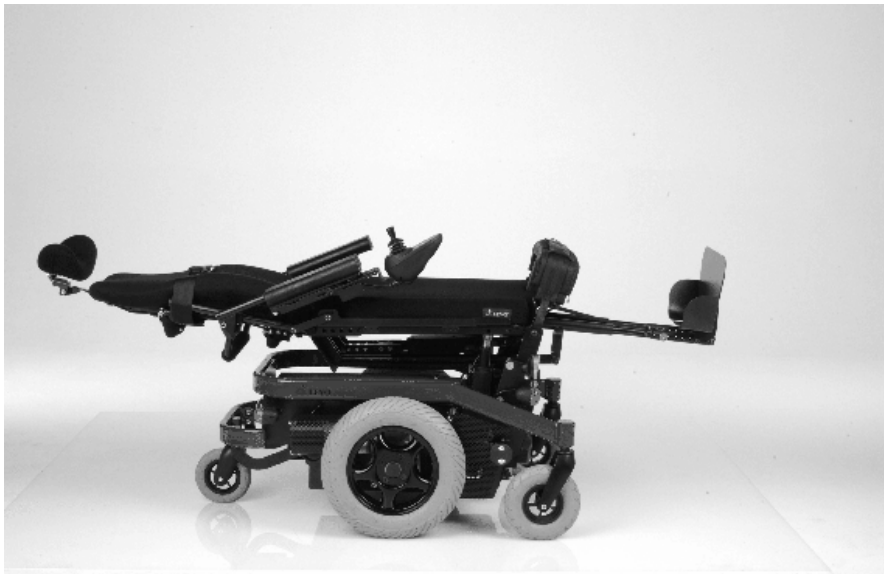

**LEVO combi**  
Lying position (option) and  
armrest mechanism for reclined  
position (option)



**LEVO combi**  
Sitting position shown with  
powered reclining backrest  
and legrest (options).



**LEVO combi**  
Relax position (option)



## Declaration of Conformity

As manufacturer of the LEVO Stand-up wheelchair, the company

**LEVO AG**

Anglikerstrasse 20

CH-5610 Wohlen

Switzerland

Tel.: +41 (0)56-618 4411

Fax: +41 (0)56-618 4410

Email: office@levo.ch

Internet: <http://www.levo.ch>

declares in all responsibility that the product hereby mentioned (see following list) corresponds with the valid direction of the EC instructions for medical products determined 14th June, 1993 (93/42/EWG).

Moreover we declare valid the correspondence of this products with following norms / nominal documents:

- EN 12 184**      **Electrically powered wheelchairs, scooters and their chargers**
- UNI 14971**    **Medical Equipment – Risk Management**
- EN 60601-1-2** **Medical electrical equipment: General requirements for safety, electromagnetic compatibility**
- EN 61000-4-2** **Electromagnetic compatibility (EMC): Electrostatic discharge immunity test**
- EN 61000-4-3** **Electromagnetic compatibility (EMC): Radiated, radio-frequency, electromagnetic field immunity test**
- EN 61000-4-4** **Electromagnetic compatibility (EMC): Electrical fast transient/burst immunity test**
- EN 61000-4-5** **Electromagnetic compatibility (EMC): Surge immunity test**

**Type of stand-up wheelchairs:**

*LEVO Combi*    S-M / L-XL

Wohlen, July 1. 2004

Dr. Kurt H. Fischer    Thomas Räber

## Seating and Standing Assessment

Seat depth: correct



Knee support attachment screw even with center of knee

Seat depth: too long



Knee support attachment screw beyond center of knee

Seat depth: too short



Knee support attachment screw short of center of knee



Ankle/Knee/Hip joint straight



Knee joint hyper extended



Incomplete knee extension

Correct position



Seat cushion too high



Cushion for pressure relief in seated position

Back too deep/thick



Backrest cushion or solid back for more comfort or stability

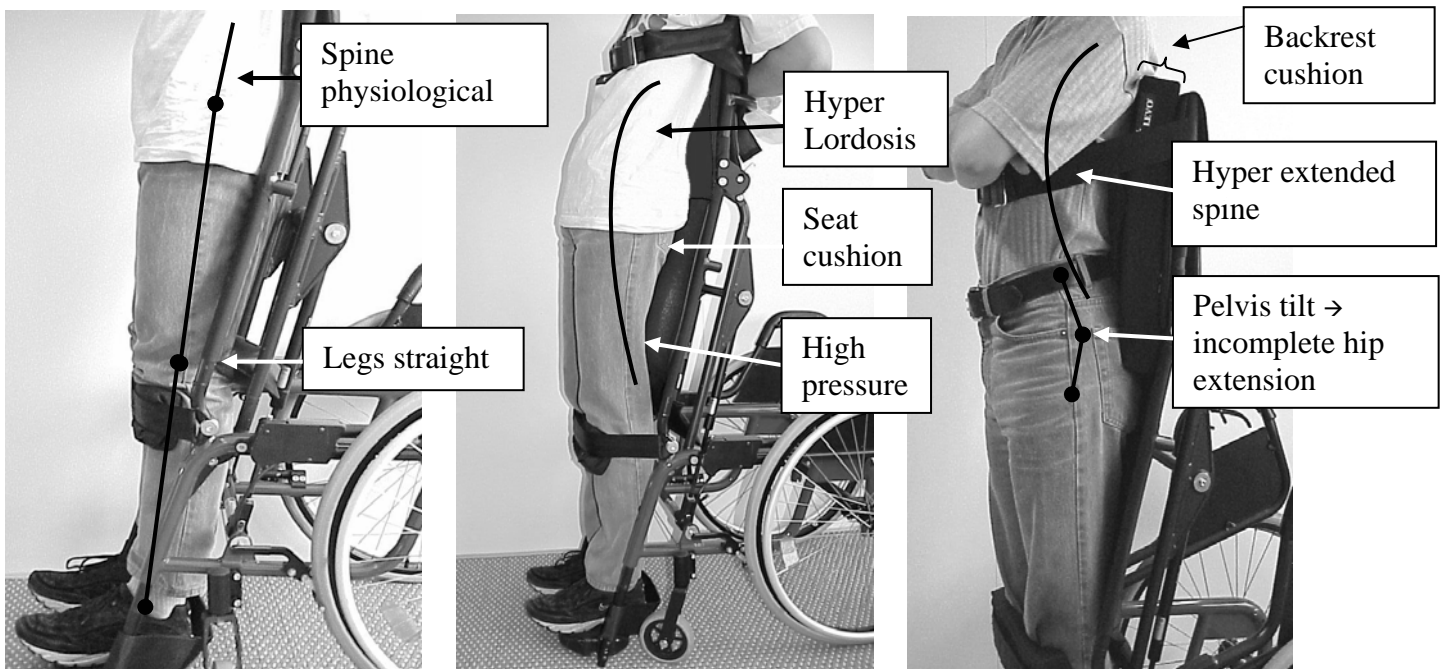

## 1. Introduction

Thank you to choose the LEVO *combi*.

The LEVO *combi* has been designed as a powered stand-up wheelchair for indoor and outdoor use. As such it belongs to the wheelchair category B.

The LEVO *combi* makes it possible to stand-up and to drive in a standing as well as in a sitting position; all these functions are powered. (As an option there are more functions beside sitting and standing available.) The mentioned functions provide to the users great independence.

The LEVO *combi* is made for everyone whose muscles do not support them to propel a wheelchair manually. The LEVO *combi* is a unique aid for those facing difficulties in standing and walking.

The LEVO *combi* has been designed for older children and adults who will benefit from motorised mobility and the ability to stand up at will.

All functions are powered and it is easy to change position by using a joystick. The standard model of the LEVO *combi* allows comfortable sitting and standing on every stage between the sitting and the complete standing position. Driving is possible in all stages.

As an option the LEVO *combi* model includes a powered seat lift and/or a reclining back. The seat tilt function comes with the seat lift in a wide range of angles and correlating to the seat height, respectively the space between the battery cover and the seat plate in a limited range. Seat tilt in combination with the backrest reclining function allows the user to be in a most comfortable position called “relax”, which means the seat plate is tilted at its end, the backrest is reclined and the feet rest is raised.

As further option “lying to standing directly” can be chosen.

The wheelchair has two drive wheels in the middle, two castors at the front and one security back wheel. This construction allows easy steering. The LEVO *combi* is constructed with a mid wheel drive for the smallest turning circle. The turning radius is 57,5 cm or 22,6 inches.

For easier transportation it is possible to detach the back. The armrests lift up for easy sideways transfer.

The seat and backrest are fully adjustable to meet the needs of a wide range of users.

The maximum load weight is 120 kilograms or 265 pounds; this includes all personal belongings carried along too.

The LEVO *combi* is certificated with a **CE**-sign. This product corresponds to the regulations notified as 93/42 EWG.

Several technical features of the LEVO *combi* are protected by patents. LEVO AG possesses the US-Patent No. 5'964'473 and patents pending in other countries.

## 2. Warranty

Your LEVO product is guaranteed from the date of purchase for:

- Two years covering all material and manufacturing defects of mechanical parts.
- One year covering all electronic components including the motors.
- Batteries are excluded from the warranty.

LEVO AG will not repair or replace free of charge any part or parts found to be defective due to abuse, misuse or lack of maintenance.

Warranty claims should be directed to:

- In Switzerland LEVO AG
- Other Countries To your local agent

Addresses and telephone numbers are given on the front page.

## 3. Delivery

### 3.1. Despatch and transportation

For delivery all LEVO wheelchairs are packed in a big cardboard box. The back is detached for careful packing. Especially sensitive parts have extra protection to avoid any damages caused by transportation. All wheelchairs are carried by lorry or air freight.

### 3.2. Delivery

Because of the complex nature of this wheelchair it will be delivered and demonstrated to you by your local agent.

The wheelchair comprises the following components:

Item	Component	Number
	Wheelchair base	1
	Seat unit	1
	Backrest unit	1
	Knee support	1
	Chest strap	1
	Footrest	1
	Set of batteries	1
	Joystick unit	1
	Battery charger	1
	Accessories as on delivery note	Corresponding to order form

### 3.3. Storage

The ideal condition to store the LEVO *combi* is a temperature between  $-40^{\circ}$  and  $+60^{\circ}$  Celsius (between  $-30^{\circ}$  and  $+140^{\circ}$  Fahrenheit). The humidity should not be above 90%. Please take care to guarantee these mentioned conditions to provide a long life time for the LEVO *combi*.

## 4. Accessories

There are many kinds of suitable accessories to the LEVO *combi*. A list of accessories is available from your local agent.

## 5. Warning

For your own safety you should read and carefully follow all instructions in the manual.

- Before using the LEVO *combi*, have your LEVO dealer explain the instructions to you. It also helps if you have a friend to listen as well. Study the instruction manual yourself or if you cannot understand it, get a friend to help you doing so. Don't hesitate to ask for any explanation.
- The LEVO *combi* is designed for outdoor and indoor use. In principle it is not recommended to drive on uneven, soft or steeply sloping ground. Using the LEVO *combi* outdoors switch on the lights at dawn and dusk and in the dark of course.
- Avoid driving through puddles. The wheelchair and especially electrical components are very sensitive to too much water even some splashes of water don't harm. (There is a danger of false function regarding some electrical parts getting too wet.)
- It is not recommended to drive long distances in the standing position in outdoor areas. This function is meant for moving around standing indoors, as in the kitchen or in the office for examples.
- The LEVO *combi* is a complicated piece of machinery. Do not attempt to maintain it yourself. For all maintenance work, please contact an authorized dealer. It is recommended that your authorized dealer is in charge to services the wheelchair once every year.
- Standing up stresses your body in ways you may not be used to. Therefore we recommend you to consult your doctor or physical therapist before using the LEVO *combi*.
- The LEVO *combi* is only allowed to bring you into the stand-up position when the free wheel device is "ON", this guarantees the motor brakes function correctly.
- We recommend to stand-up only when in company in case of sudden spasticity, convulsions and similar problems.
- To eliminate a potential risk of tipping while driving in the standing position, the LEVO *combi* features a tilt switch. The tilt switch system prevents to drive in the complete or

almost complete standing position on ground showing a wide downtilt. Increases the downtilt to 3 degrees (only at downhill rides), it will be impossible to continue to drive in the complete or almost complete standing position. To drive on lower the seat, respectively reduce the standing angle.

- Before standing up it is absolutely vital that the knee support and chest strap are fitted correctly (see section 8) and the two backrest locking pins are properly located. Always check these pins so they are fully in place each time you use the wheelchair.
- **Important:** Check if the quick release axles are fitted correctly into the leg rest tubes and so the footplate is fixed securely at the leg rest pieces.
- The following symbols are to be found on the wheelchair:



Warning, risk of pinching! Make sure no parts of the body, clothing or other items get jammed.



Warning, read user's manual!

**Caution:** Federal law restricts this device to sale by or on the order of a medical professional licensed by the law of the State in which he /she practices.

You should under no circumstances attempt to stand up without following all safety precautions.

## 6. Preparing the wheelchair for use and operation

A specialist should be responsible for first adjustments and he should get the chair ready for operation.

- Please make sure that all components listed are delivered with the chair. Check the list shown in sector 3.2.

### 6.1. LEVO combi standard backrest

Information about the assembly of the LEVO *combi* standard backrest is printed under the sector 7.6. The standard backrest is not developed for quick fitting and removing.

## 6.2. V-Trak backrest system (optional)

### Fitting and removing the V-Trak backrest

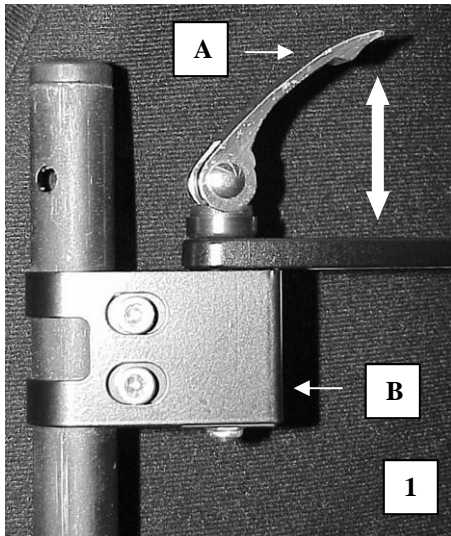

- Lift both backrest levers (A) at the back shell the way that they can turn freely.

#### Fitting:

- For fitting the back stick the clamp bolt of both backrest levers in the tubes of the connecting piece (B) of both backrest tubes. The back shell should be in front of the backrest tubes for fitting. For fixing both backrest lever (A) push them down. (See picture 1).

#### Removing:

- For removing the back fold the backrest lever (A) up on both sides. Now lift the backrest up and remove it.

## 6.3. Further preparations

- Fold down the footrest.
- Put the seat upholstery on the seat. Fix the upholstery on the seat metal plate using the velcro fastener.
- Screw the joystick module to the intended holder at the armrest.
- Plug in the control cable behind the joystick module.
- Check that the free wheel device is clicked shut and the motor brakes function. (For more information about that subject consult sector 14)
- Ensure that the main fuse below the battery cover is put on.

## 7. First adjustments

### 7.1. Seat depth

The seat depth has to be adjusted to the length of the upper legs. Precise adjustment is very important considering a perfect sitting and standing position. Let a specialist adjust your seat depth according to the measurements indicated on the order form.

For an individual adjustment of the seat depth it is necessary to change four components:

1. Seat support plate
2. Both seat supports
3. Adjusting lever on the right hand side
4. Adjusting lever on the left hand side

Is the LEVO *combi* equipped with the option reclining backrest, it is also necessary to adapt the adjustable plates of the actuator for backrest reclining.  
(See picture 4, B)



The seat cushion is fixed on the adjustable plate of the seat support made of metal.

- Detach the seat cushion first.
- Move the seat in a more upright position using the joystick module for easier access.
- Switch off the joystick module as well as the fuse automatic.
- Remove the four adjusting screws on the seat support plate using a 4 mm hexagon key, to adjust the depth of the seat support plate. (See picture 2).

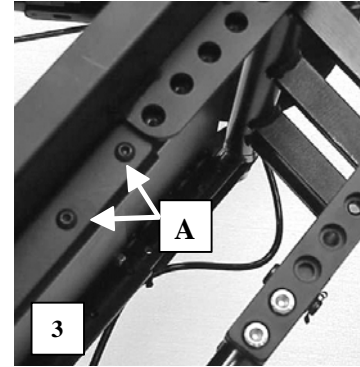
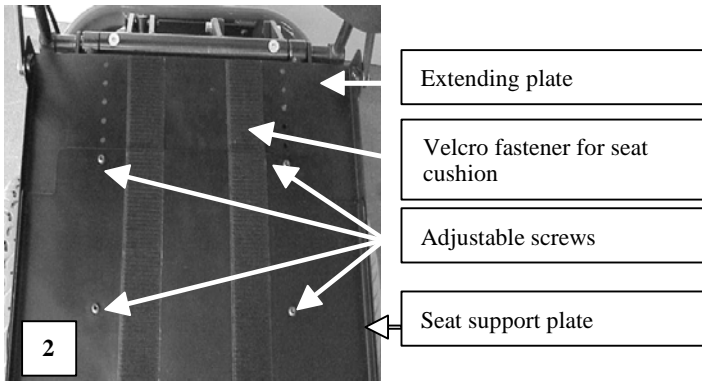

- Remove two screws (A) at each seat support using a 4 mm hexagon key. (See picture 3). Pull or push the seat support in the requested position and tighten the screws. (all positions must be adjusted to the same number, see positions-marks in picture 3a and 3b)
- Push the extending plate to the corresponding position and also tighten the screws. (See picture 2).

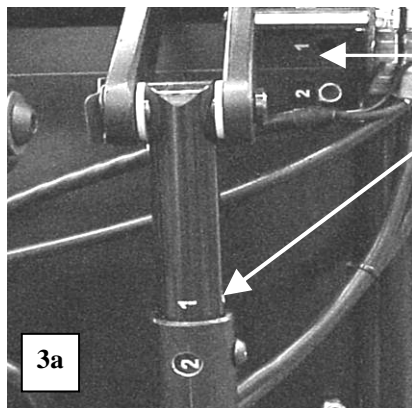

Marks

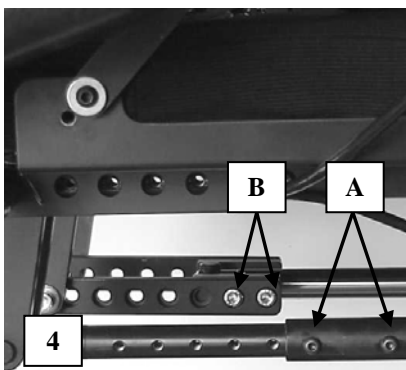
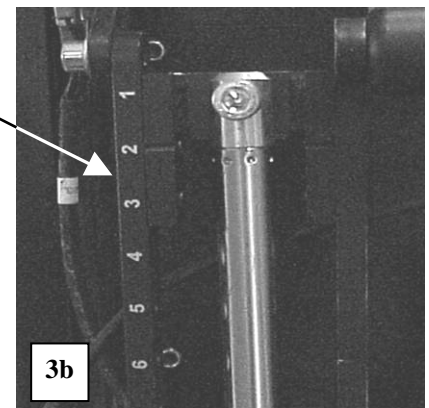

For any changes of position regarding the adjusting lever and the adjustable plates of the actuator for backrest reclining, please follow the instructions:

- Remove both screws (A) from the adjusting lever using a 4 mm hexagon key. (See picture 4).
- Remove all together four screws (B) from the adjusting plates of the actuator for backrest reclining using an 6 mm hexagon key. (See picture 4).
- Push or pull the adjusting lever and the adjusting plate to the correspondent position and tighten all screws.

**Important:** When changing the seat depth please take care that all four components (seat support, extending plate, adjustable lever and adjustable plate) are adjusted at the same time! All four components must be fixed at exactly the same position (see picture 3 and 4).

## 7.2. Seat cushion

The seat cushion is shaped in such a way at the front edge to provide you the most comfort and the ideal distribution of pressure. The cushion will be fixed with a Velcro fastener so it doesn't move around. For fixation just put it on the seat and push it down.

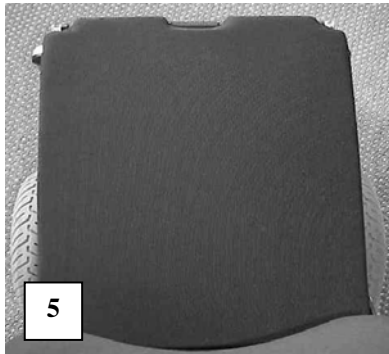

The edge in front of the cushion is shaped to cover optimally the seat. (See picture 5).

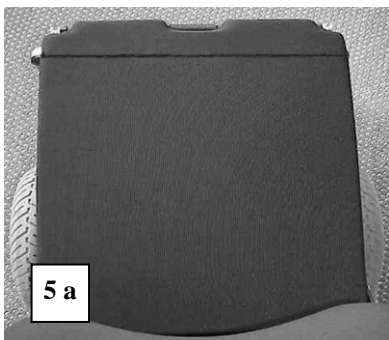

There is the possibility to use seat cushions from other manufacturers. We recommend a leg protector to avoid any risk of pressure ulcers at the front edge of the seat. The leg protector is available as an option. (See picture 5a). For more information please contact your local specialist.

## 7.3. Footplate

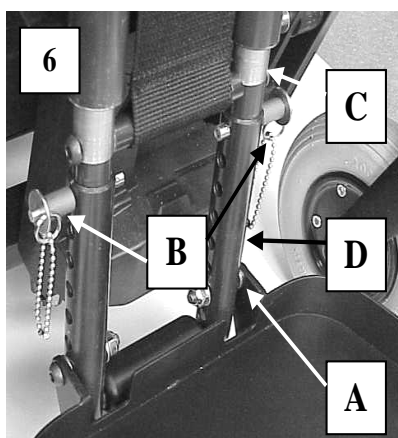

The adjustment of the footplate is possible in between a range of 13 cm/5'' (8 different positions of holes (D) with a distance of 18 mm/0.07'' from one to the next). Adjust the height of the footplate removing both hexagon screws (A) by using a 6 mm and a 10 mm hexagon key (see picture 6). Lift the footplate to the requested height and tighten the screws.

- In case the footplate is meant to be fixed at the most upper position, so replace the quick release axle by a hexagon screw (A).

For transportation the footplate and the leg rest tubes can be detached.

Use the lift function or put the chair in the lying position.

- Push the button in the center of the quick release (B) and pull these pieces out of both leg rest. (See picture 6).
- Remove the leg rest including the footplate.

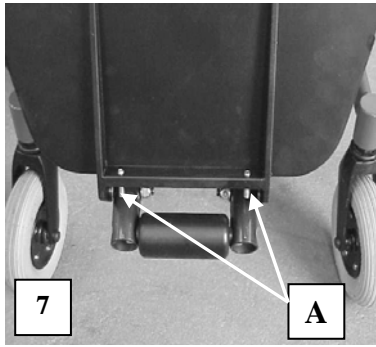

The angle of the footplate can be changed in a range from minus 5° to plus 15° to the horizontal level. To put the angle of the footplate in the requested position adjust the two threaded pins (A) below the footplate using a 6 mm hexagon key. Turn the pins in or out just the way needed to get the requested angle of the footplate.

**Caution:** Both pins must touch the leg rests when the footrests are in a flip-down position.

#### 7.4. Armrest

The armrest can be put in a flip-up position for an easy transfer sideways. This also allows a better access to the chair. (See picture 8).

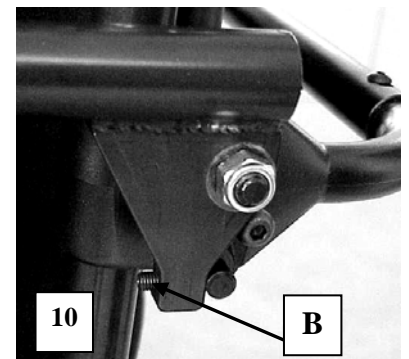
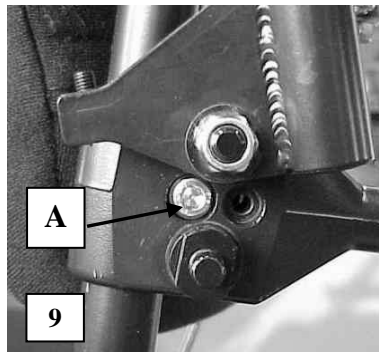
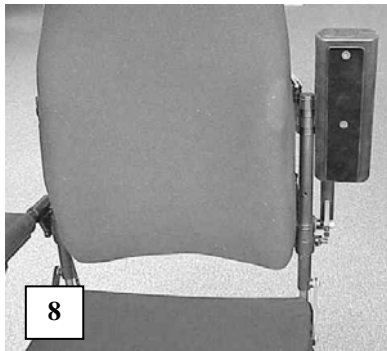

The height of the armrests is fully adjustable in between a range of 14 cm/5.5" to 33 cm/13"; the height of the armrest is measured from the upper edge of the seat cushion to the upper part of the armrest.

- Loosen the cylindrical screw on either side of the armrest joints using a 5 mm hexagon key. (See picture 9).
- Now push the connecting rod and the armrest joints along the backrest tube for the ideal position.
- Tighten the cylindrical screw on the right and left side.

The angle of the armrest is also adjustable.

- For lifting the armrest in front turn the threaded pin in (B) using a 2,5 mm hexagon key. Turn the pin clock wise further in the armrest joints. (See picture 10).
- For lowering the armrest in front turn the threaded pin out (B) using a 2,5 mm hexagon key. Turn the pin counter clock wise further out of the armrest joints. (See picture 10).

The support of the joystick module can be swung away to the side and further pushed back. This allows the wheelchair user to get closer to the table.

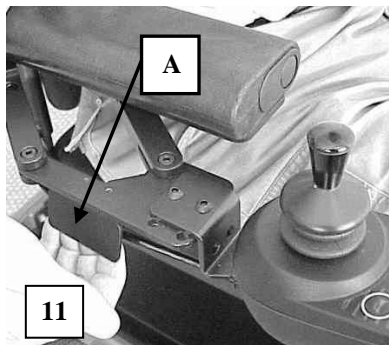

- Push the release catch (A) to the side and backwards simultaneously (see picture 11). Now move the joystick module first to the side and then backwards.

As a further option the LEVO *combi* features a tilted armrest mechanism. (See picture 24 on page 22). Armrests tilting while changing position from sitting to lying, provide most comfort to the user, because his arms are horizontally well-positioned and they feel continuously stable. This function is set on the program and, therefore, there is no action necessary. The tilted armrest mechanism also function reversed, that means that the armrests raise, when the chair is moved back from the lying or relaxing position to the sitting position or as well when activating the function (optional) “lying to standing directly”. During both actions the armrests move in such a way that the user’s arms are lying stable and comfortably on it.

**Caution:** Do not use the joystick as a support. Please use the armrests to support you when transferring to another chair or to the bed or back to the LEVO *combi*.

**Caution:** To prevent the risk of snapping off the joystick module, please be careful and avoid hitting the joystick against any object.

#### 7.5. Low shearing at the back

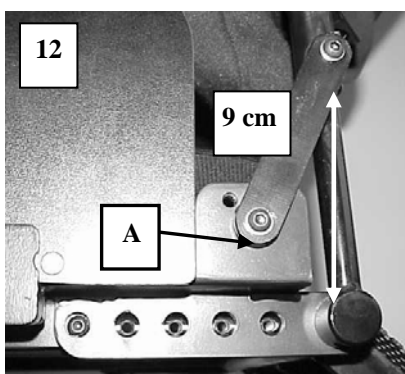

The LEVO *combi* is equipped with a new low shearing mechanism (see picture 12) which eliminates the shearing movements for most comfort as a user benefit in a sitting as well as standing position. This shearing mechanism counteracts to the shifting of the wheelchair's back towards the upper body of the user. This shifting movements were often considered as uncomfortable. Thanks to the low shearing mechanism the LEVO *combi* feels like tailor made in each position. The most comfortable stand-up motion is also realized by the fact that the distance between the armrest and shoulders stays constantly the same.

The new unique low shearing mechanism is adjustable to the individual body measurements using correlatively one of the three different positions to mount the connecting piece (A). As a standard the connecting piece is fixed to middle drill hole; this means the medium adjustment and the compensation of 9 cm / 3.5". Fixing the connecting piece on one of the other holes the compensation will be of 8 cm / 3", respectively 10 cm / 4". Please read the service instructions for more information about this subject. (Service instruction section 8.6.)

## 7.6. Backrest assembly of the LEVO *combi* standard backrest

The standard backrest consists of a fabric covering. Around the backrest tubes are four strong broad straps with stitched on Velcro fastener mounted. The straps are hidden under a cover which is fixed with a Velcro fastener to the seat plate. The cover is lightly cushioned and is positioned over the front of the backrest. The back part is covered by a strong fabric.

### Adjustment of the backrest

The standard backrest can be individually adjusted.

- Remove the back cover from the backrest to get access to the straps.
- Span each of the four straps individually according the needs of the user to optimize the support in the sitting position.
- Put the back cover back in place.

## 7.7. V-Trak backrest system (option)

The LEVO *combi* can be supplied optionally with the V-Trak backrest system, which guarantees most comfortable sitting. The V-Trak system provides features for most individual adjustment. The backrest consists of a comfortable padded adjustable back shell and a fully adjustable mounting system. A backrest of 63 cm / 25 inches length is known as a V-Trak standard. Further options are available such as a head support for example.

For more information about the backrest systems please contact an authorized dealer.

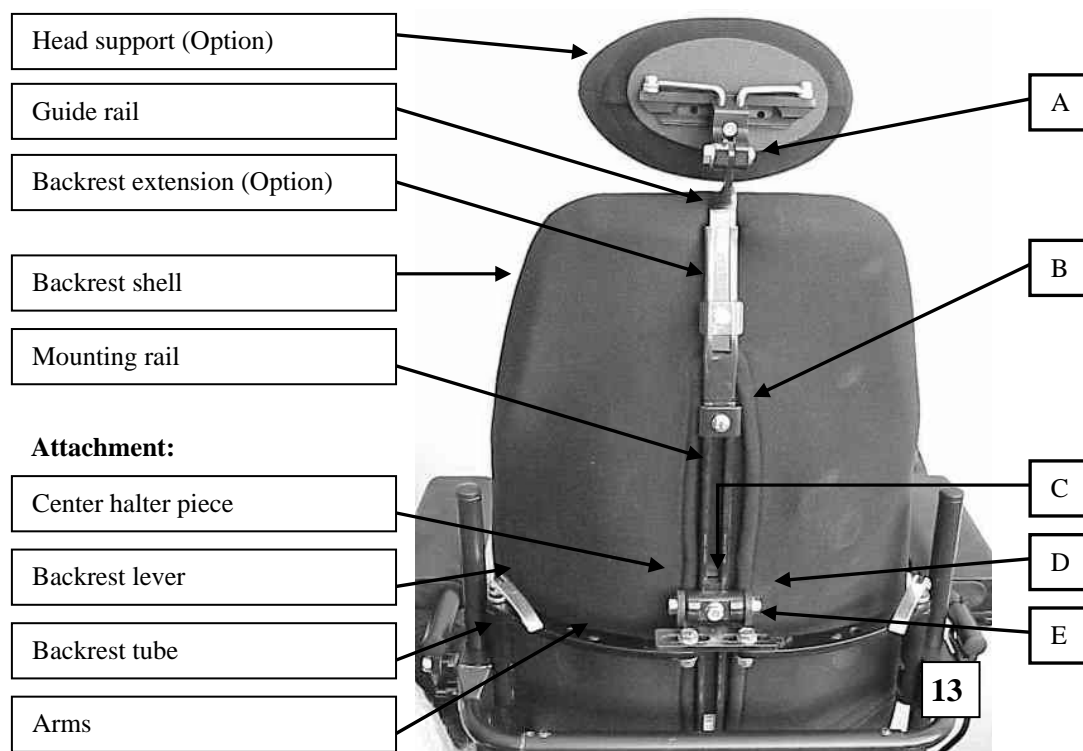

## Adjustments of the backrest

### Backrest depth:

- Loosen the two arm pivot bolts and nuts (E) using a 13 mm spanner.
- Move the backrest forwards or backwards to the desired location (see picture 13).
- Retighten the bolts and nuts.

### Backrest height:

- Loosen the height set bolts (C) using a 13 mm spanner.
- Move the backrest up or down to the desired location (see picture 13).
- Retighten the bolts.

### Backrest rake (recline):

- Loosen the two rake set bolts (D) using a 13 mm spanner.
- Rotate the backrest to the desired location (see picture 13).
- Retighten the bolts.

### Adjustment of back shell:

The tension of the backrest cushion can be changed as follows:

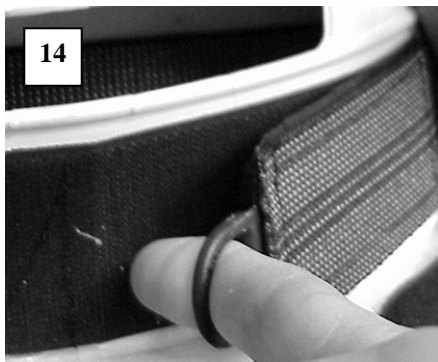

- Peel back the rear cover of the backrest to expose the adjustment straps.
- Put finger through loop as shown and pull the strap off the Velcro fastener (see picture 14).
- Increase or decrease the tension on the strap to the desired level and press the strap down onto the Velcro fastener.
- Repeat for each strap.
- When you are satisfied with the tension on the cushion refit the rear cover.

### Adjustment of the head support (option)

- To remove the head support, loosen the screw (B) using a 10 mm screwdriver.
- Lift the head support (see picture 13).
- To refit the head support, push the guide rail of the head support into the mounting rail.
- Retighten the screw.
- For the adjustment of the head support rake loosen the screw (A) and retighten it at the desired position. (See again picture 13).

**Important:** To mount a head support to a 63 cm/25” or a 80 cm/31.5” back rest ex post there is a rail extension necessary.

For additional adjustment of the backrest as well as for information about accessories to the backrest please contact your local specialist.

## 8. Safety harness

The safety harness consists of two parts: a chest strap and a knee support.

**Caution:** Before attempting to stand in your wheelchair fit and adjust the chest strap and the knee support.

### 8.1. Knee support

The knee support helps your knee not to bow in the standing position; you are standing with your legs totally stretched. Beside that the knee support keeps you in the perfect position during the stand-up motion.

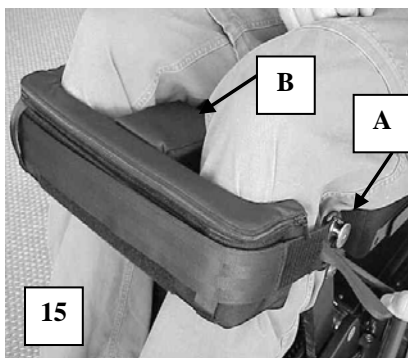

- Attach the two eyes of the knee support to the big double-head screw on either side of the wheelchair (A). (See picture 15).
- Fit the knee support over your legs so that the knee wedge is between your legs (B). Close the quick release catch on the belt.
- The knee support should be just below the kneecap (max. 2 finger widths). Tighten the belt until there is just enough room to insert a hand between the support and your leg.

### 8.2. Chest strap

Standard backrest of the LEVO *combi*

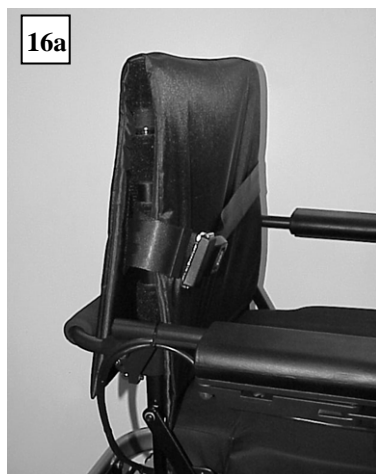

Remove the back cover of the backrest upholstery. Pull it from the Velcro band and fold it up. Press now the Velcro strip of the chest strap onto Velcro bands of the backrest. Fold down the back cover and push it back on the Velcro band of the backrest.

The chest strap passes around the backrest tubes. The height of the chest strap may be changed. Simply readjust it by following again the instructions above. (See picture 16a)

## V-Trak backrest (Option)



Press the Velcro strip of the chest strap onto the back of the backrest. Make sure the chest strap is passed around the backrest and the backrest tubes. The height of the chest strap may be changed. Simply pull it off the backrest and refit it to the desired position. (See picture 16b)



Pass the strap around to the front of the wheelchair and secure over your chest using the quick release buckle. (See picture 16c). Adjust the length of the strap so that it is not too tight but fits comfortably across your chest.

The length of the chest strap can be adjusted as follows. To loosen, hold the belt buckle at a right angle to the belt and pull. To tighten, buckle the belt together and pull on the end of the belt.

## 9. Using the LEVO combi

**Warning:** To avoid any risk of tipping over the LEVO *combi* must only be used in the stand-up position on firm level ground.

### 9.1. Getting into the wheelchair

- Make sure the wheelchair joystick module is switched off.
- Check if the motor disengaging lever is in the ON position for no movements of the powered wheels.
- Lift up the footplates.
- Transfer yourself onto the seat using the armrests for support or have yourself transferred onto the seat.
- Lock the footrests down and rest your feet on them.
- Fit the knee support and chest strap.

### 9.2. Getting out of the wheelchair

- Make sure the wheelchair joystick module is switched off.
- Check if the motor disengaging lever is in the ON position for no movements of the powered wheels.
- Remove the chest strap and knee support.
- Lift up the foot plates.
- Transfer yourself in your usual way out of the wheelchair or have yourself transferred out of the wheelchair.



### 9.3. Sideways transfer

- Drive as close as possible to a chair, bed or any other objects you want to transfer to.
- Make sure the joystick module is switched off.
- Check if the motor disengaging lever is in the ON position for no movements of the powered wheels.
- Flip up the footrest of the wheelchair and put your feet on the ground.
- Lift up the armrest on the side you are transferring to.
- Transfer yourself in your usual way out of the wheelchair or have yourself transferred out of the wheelchair.

### 9.4. Skirt guards



As an option there are skirt guards available. A skirt guard is put on either side of the seat plate. (See picture 17a). Mounting and dismounting can easily be done by hand. Please read the following instructions for taking the skirt guards off and see the pictures 17b to 17e. To put the skirt guards back in place follow the instruction in the reverse order.

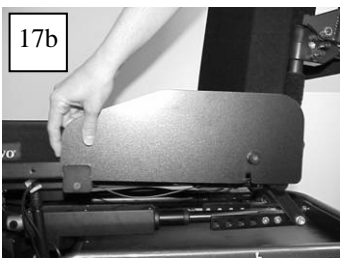

1. Grasp the skirt guard with your hand at the front edge.

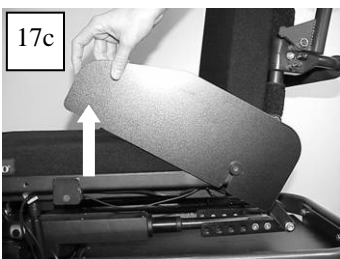

2. Lift the skirt guard.



3. Move the skirt guard backwards and down until the double-head screw is blocked by the left end of the jog.

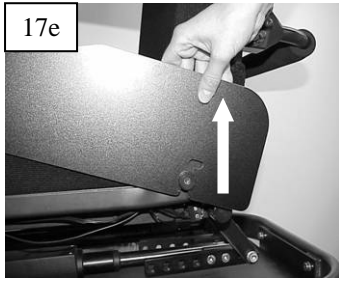

4. Pull up the skirt guard the way that the double-head screw slides along the vertical jog and the guard can be completely removed from the chair.

## 10. The safety cut-out

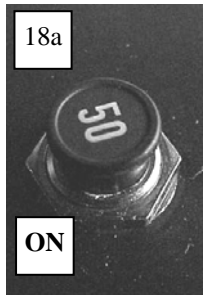

The safety cut-out situated on the battery cover must be switched ON. You can reach it sitting in the wheelchair on the left hand side under the front edge of the side cover.

The safety cut-out system protects the stand-up mechanism, the motors and controller circuits against too high electrical power. Push the switch down to switch it ON (see picture 18 a). Pull the switch up to switch it OFF (see picture 18 b).

We suggest for convenience you leave this switch ON.

## 11. Joystick module

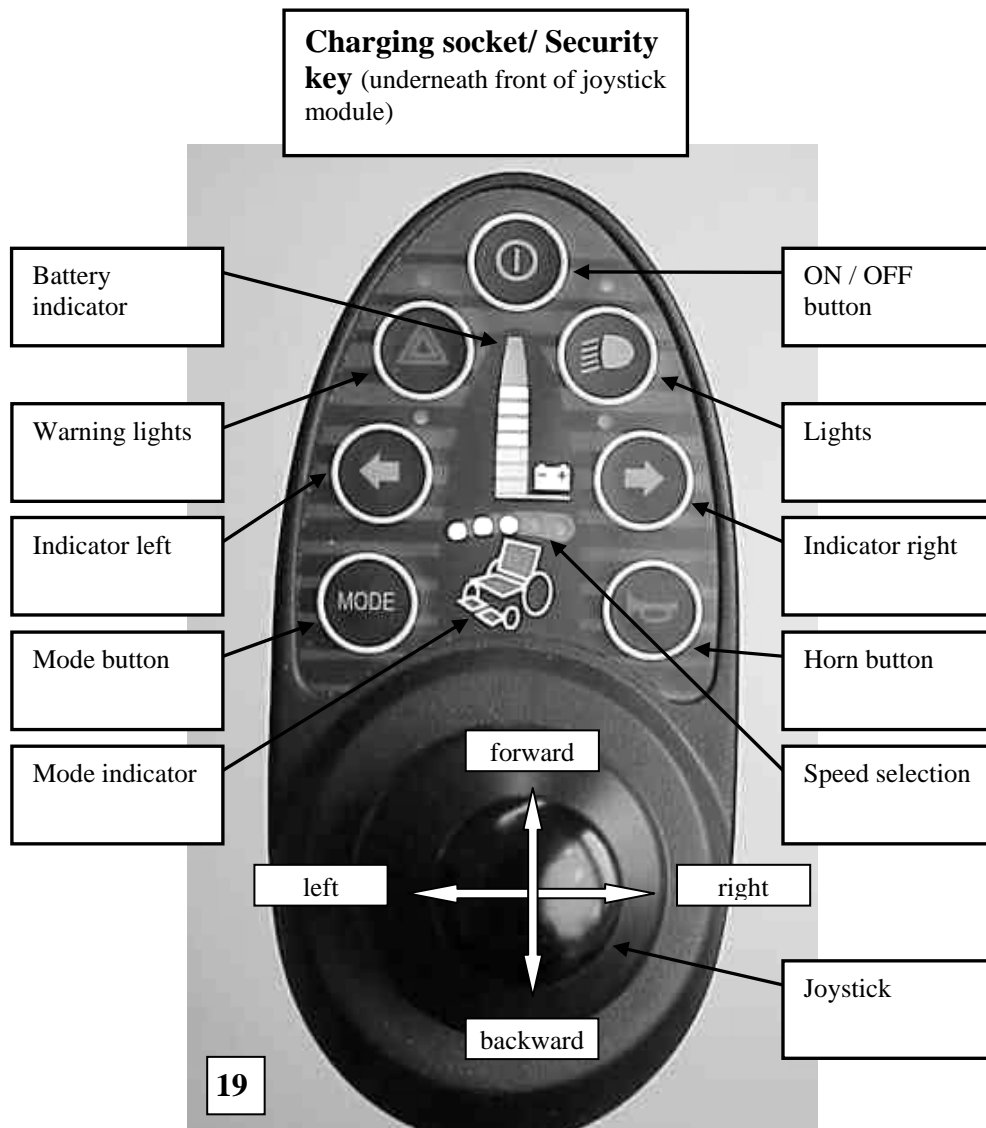

### Warnings:

- Avoid knocking your joystick module and especially the joystick.
- Be careful not to drive the joystick module into obstacles.
- Avoid damage to cables.
- Do not let your joystick module get damp or contaminated with food or drink. If it gets damp or dirty clean it off as soon as possible.
- Always clean your joystick module with a cloth dampened with diluted detergent. Never use abrasive or spirit cleaners.

### 11.1. Security key

A security key is supplied to your LEVO *combi* to lock your joystick module to prevent unauthorized use. With this security system goes a key which you will find delivered with the chair.

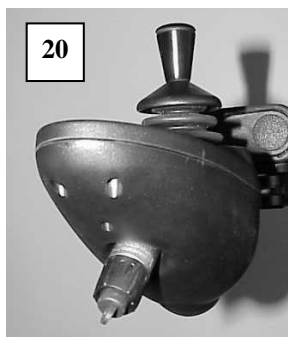

To lock: switch on the joystick module then insert the key into and remove it from the charging socket at the front of the joystick module (see picture 20). The wheelchair cannot be driven and the standing function as other functions are disabled.

To unlock: switch on the joystick module then insert the key into and remove it from the charging socket at the front of the joystick module (see picture 20). The wheelchair can now be driven and the standing function as other functions are enabled again.

### 11.2. On / Off switch

Press once to turn the joystick module on, press again to turn it off. (See picture 19).

### 11.3. Battery indicator

The battery indicator lights up when the joystick module is switched on (see picture 19). The indicator shows you the level of battery charge left in the batteries. (Also see section 16.1 charging the batteries). It also indicates any faults; details are given in section 22.

### 11.4. Joystick

The joystick controls the direction and speed of the wheelchair. The joystick is also used to choose the different mode functions. (See picture 19).

To drive forwards push the joystick forwards. The further you push it from the centre the faster the wheelchair will move. Let go of the joystick and the wheelchair will stop and the brakes come on.

For backwards driving push the joystick backwards. Pushing the joystick to the right side means a right hand curve as a reaction. Pushing the joystick to the left then the chair will drive to the left hand side.

For information about choosing different mode functions please consult sector 11.6.

### 11.5. Speed selection

The display shows the present speed setting of the wheelchair. There are five speed settings. One light lights for the slowest speed and five lights lit for the fastest speed.

To change the speed when stopped press the MODE button once then move the joystick to the right to increase speed (more lights lit) or to the left to decrease speed (less lights lit).

You can also change the speed while driving. Press the MODE button and the speed will be increased by one step. Repeated pressing of the MODE button will increase the speed until 5 lights are lit (maximum speed). If the MODE button is pressed once more the speed automatically returns to the slowest.

The maximum speed is 10/8/6 km/h respectively 6/5/3,7 mph. The lowest speed to drive (one light lit) is approximately 40 % of its maximum.

For safety we advise you to change the speed when the wheelchair is stationary.

## 11.6. Mode functions

### Standing (standard function)



The LEVO *combi* is supplied with a stand-up function to set the seat and the back of the chair upright for an almost completely upright standing position. (See picture 21).

To operate the stand-up mechanism, with the wheelchair stopped, press the MODE button (see picture 19) until the red indicator light comes on at the wheelchair symbol. Move the joystick to the left or right side until the indicator lights are at the seat and at the back of the wheelchair symbol. This way you select the mode for the standing function.

To raise the seat push the joystick forward. To lower the seat pull the joystick backward. To stop in any position between seated and well standing just let go of the joystick. To stand up to the full standing position, push the joystick forward until the mechanism switches off automatically. To lower the seat again just pull the joystick back towards yourself.

## Lift (optional function)



The LEVO *combi* can optionally be supplied with a lifting function to horizontally raise the seat up to 15 cm / 6". (See picture 22).

To operate the lift mechanism, with the wheelchair stopped, press the MODE button (see picture 19) until the red indicator light comes on at the wheelchair symbol just set at the seat. This way you select the mode for the lift function. Whenever the indicator light is on the seat of the wheelchair symbol, the lift function is activated.

To raise the seat, push the joystick forward. To lower the seat, pull the joystick backward. To stop at any level of sitting height just let go of the joystick. To sit as high as possible, push the joystick forwards until the mechanism switches off automatically. To lower the seat again just push the joystick back towards yourself.

## Relaxing and lying position (optional function)



The LEVO *combi* can optionally be supplied with a relaxing and lying function. Activating this function the backrest reclines and the footrest raises simultaneously. (See picture 23).

To operate the mechanism for relaxing and lying press the MODE button (see picture 19) until the red indicator light comes on at the wheelchair symbol. Move the joystick to the left or right side until there is a red indicator point only at the back of the wheelchair symbol. This way you select the mode for the relax and lying function.



To recline the back and to raise the footplate, pull the joystick backwards. To get back into the sitting position or in a more upright sitting position, just push the joystick forward. To stop in any position between sitting and lying, let go of the joystick. To be transferred in a total horizontal lying position (see picture 24; including optional armrest reclining) pull the joystick backward until the mechanism switches off automatically. To sit upright again just push the joystick forwards. (Operate all these functions with the wheelchair stationary.)

For an easy transfer in the lying position (for example from the bed to the wheelchair or versus) use the lift function (optional function) to put the chair on an equal height as the other object.

## Lying to standing function (optional function)

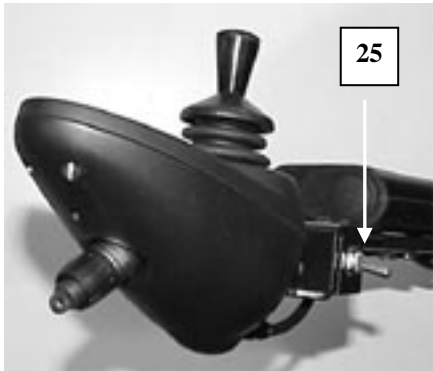

The option lying to standing moves the chair from a horizontal position directly to a total upright position. To activate this function, press the little switch on the front end of the armrest down (See picture 25. same armrest as the joystick module is mounted at). Then press the MODE button (see picture 19) until the red indicator light comes on at the wheelchair symbol. Move the joystick to the left or right side until the indicator lights point at the back and the seat of the wheelchair symbol. This way you select the mode for standing while you are in the lying position.

To raise the back and the seat plate to transfer into an upright position push the joystick forward. To return into the lying position or in a less upright position, just pull the joystick backward. To stop in any position between lying and standing, let go of the joystick.

To reach the completely upright standing position (see picture 21), push the joystick forward until the mechanism switches off automatically. To lie down again, just pull the joystick backward and let of the joystick when you feel comfortable.

Changing from standing to sitting requires to push down the little switch while you are in the total standing position. Choose the standing function by pressing the MODE button until a red light appears at wheelchair symbol. Move the joystick to the left or right side until the indicator lights are at the seat and at the back of the wheelchair symbol. Then pull the joystick backward to be seated.

Only press the little switch on the end of the armrest when the chair is in a completely lying or standing position.

Operate all these functions with the wheelchair stationary!



A position between lying and standing is just possible with the option “standing-lying direct” (picture 25a).

## Seat tilt (optional function)



The option seat tilt is only possible with the option seat lift. Depending on the seat height of the *LEVO combi* and the space between seat plate and cover of the batteries it allows you to lower the seat plate at its back end to get into a more stable position which is especially appreciated for driving. (See picture 26.)

There are two steps needed to tilt the seat. Press the MODE button until the red indicator light comes on at the wheelchair symbol, just set at the seat. Now the seat lift is activated. Push the joystick forward until the maximum seat height is reached and the mechanism switches off automatically. Then move the joystick to the left or right side until the indicator lights are at the back and the seat of the wheelchair symbol. Pull the joystick backward and the seat plate will lower at its back end. Let go of the joystick

if you feel to be in a comfortable position. This mechanism will switch off automatically as soon as the seat plate touches the cover of the batteries. Then the seat reached its maximum tilt angle.

## Relax position including seat tilt (optional function)



This position called “relax” is a further option which allows a most comfortable position for activities as reading, listening to music, watching TV or just relaxing. This function can only be operated with the options “backrest reclining” and “seat lift” (when the user’s seat height is rather high this option works limitedly without the seat lift function). (See picture 27.)

Being in the position with a comfortable seat tilt is the initial position to relax. Please read in chapter “seat tilt” the description how to tilt your seat. Now check if there is a red indicator light on the wheelchair symbol. If not, press the MODE button (see picture 19) until a red indicator light is on the seat of the wheelchair symbol. Move the joystick to the left or right side until the indicator light points only at the back of the wheelchair symbol. This way you select the mode for the backrest reclining function. Pull the joystick backwards and you will be moved to the relax position. To stop when you feel comfortable, just let go of the joystick.

## 11.7. Lighting installation

The lighting installation of the *LEVO combi* includes two white lights pointing forwards and two red lights pointing backwards as well as four indicators.

### Light

Press the light switch (see picture 19), in case of driving outside at night or at dawn. We recommend driving with the lights on as soon as there are bad light conditions so that you can be seen by anyone.



**Important:** Please notice that the capacity of the batteries is affected by using the lights.

#### Indicator

Press the right indicator switch any time you like to turn right. After turning switch off the indicator by pressing the same switch again. (See picture 19).

Press the left indicator switch any time you like to turn to the left hand side. After turning switch off the indicator by pressing the same switch again. (See picture 19).

#### Flashing warning light

Press the switch for the flashing warning lights (see picture 19) for parking at blind and dangerous spots. Switching on the flashing warning lights all four lights blink. Press the switch again for deactivating these lights.

Check the function of all lights at regular intervals. Repair any fault found.

### 11.8. Horn

To warn other people of your presence press the horn button (see picture 19) and the warning horn will sound. Please be careful when using the horn. Repeated and inappropriate use will only upset those around you. Only use the horn as a warning to other people and not as a way of getting them to move out of your way.

## 12. Electromagnetic interference (EMI)

**Important:** You must be aware of the effect of electromagnetic interference (EMI) regarding your LEVO *combi*. Please study the following facts carefully.

#### Electromagnetical interference of transmitter and radio wavelength

Powered wheelchairs might be influenced by strong electromagnetic interference. This interference is caused by radio and tv stations, amateur radio sets (walkie-talkie), two-way radios and mobile phones. Interference (especially of radio stations) might have an influence on the brakes of a powered wheelchair so that they get released and so the chair runs away. It could also happen that the wheelchair starts driving in a not desired direction or the stand-up function could operate non-requestedly. There could occur constant damages to the steering system of the powered wheelchair.

The intensity of power is measured in volt per meter (vpm). All powered wheelchairs are able to resist to a certain amount of electromagnetic interference. This is called "level of disruptive strength". The security depends on the level of disruptive strength; the higher the level the better the protection. Thanks to modern technology the capability of disruptive strength is up to 20 vpm.

The LEVO *combi* standard version (no further measures) is supplied with a disruptive strength level of 20 vpm.

The LEVO *combi* is constructed to resisted to a regular level of interference as it occurs in a household. Beside that there exists a certain number of sources of relatively strong magnetic fields to which you should stay in a save distance. Some of these magnetic fields are obvious and easy to avoid. Some other are not easy to be realized and it is hard to stay off at times.

Please take knowledge of the following list of sources of interference and avoid getting close to these disruptive factors. The EMI-risk is reduced to the minimum when you follow these instructions.

The sources of radiated EMI is put in three categories:

- Portable sender and receiver on which an aerial is directly mounted. Examples: CB-radio, walkie-talkie, sender and receiver of alarming systems, fire alarm, police radio equipment, mobile phone and various private communication systems.  
Please notice: Some mobile phones and similar objects transmit signals as soon as they are switched on even if they are not in use at the moment!  
There have not been any known incidents caused by mobile phones to date.
- Mobile sender and receiver of intermediate range, as they are installed in police cars, fire engines, ambulances and cubs. The aerial is normally fixed on the outside of the vehicle.
- Sender and receiver of a huge range, as radio and TV stations and amateur radio sets.

Be aware that wireless phones, lap tops, AM/FM-radios, TVs, CD players, recorders as well as gadgets like razors, hair dryers and so on are only small sources of electromagnetical interference. These objects don't cause any problems regarding the functionality of the LEVO *combi*.

Electromagnetical interference in regard to a powered wheelchair

Considering that electromagnetical power reaches high intensity in just a short time as soon as you get close to the source, it is advised to take especially care carrying a sender and receiver with you. It might occur that an item as mentioned gets very close to the controller of the wheelchair and like that electromagnetic energy gets unintendedly too close too. In this situation the electromagnetic energy might influence negatively the function of brakes as well as the motion characteristics of the wheelchair.

### **13. Driving the wheelchair**

Before starting to drive your wheelchair take time to read all the instructions regarding the LEVO *combi* and to get to know the controls. When first learning to drive your wheelchair, practice in an area you know well. We suggest a large flat smooth area such as your living room or the driveway to your home. Do not attempt to drive the wheelchair in confined areas or where there is traffic until you are sure you can control the wheelchair safely.

When driving outdoors always have the seat plate in a horizontal position or tilted backwards (in case seat angle tilt is an optional function).

Switch on the joystick module and practice driving the wheelchair slowly forwards, backwards and turning side to side. When you have more confidence increase the speed and practice until you have mastered driving the wheelchair.

It is possible to drive the wheelchair in the standing position. Speeds are cut to half the speed as soon as the seat leaves the lowest seat position. When indoors practice standing up in the wheelchair and slowly driving it across the room.

The wheelchair allows to drive absolutely safely in a sitting position on slopes with a maximum gradient up to 10 degree. When driving up or down steeper slopes than this or over

uneven ground, braking and steering response will be limited due to reduced traction. When on a slope don't lean out of the wheelchair down the slope. Danger of tipping. Driving in a standing position is no problem up to a gradient of 3 degree.

A limit switch with some important security features programmed is a standard of the LEVO *combi*. In correlation of the current position of the chair and the inclination of the ground the speed is automatically reduced. In extreme situations the system prohibits to continuing driving for the safety of the user. It is be possible to go on as soon as the seat plate is lowered. Please read the detailed information below.

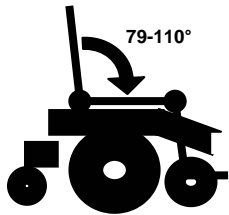

Chair drives up to 100% of maximum speed

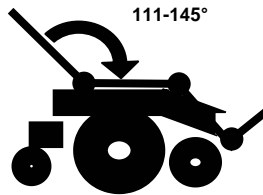

Chair drives up to 40% of maximum speed

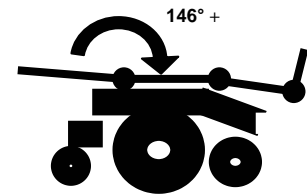

Chair drives up to 10% of maximum speed

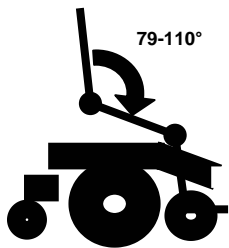

Chair drives up to 100% of maximum speed



Chair drives up to 40% of maximum speed

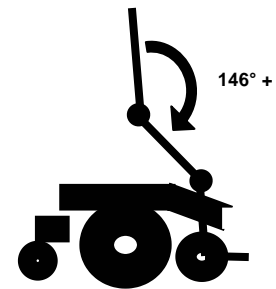

Chair drives up to 10% of maximum speed

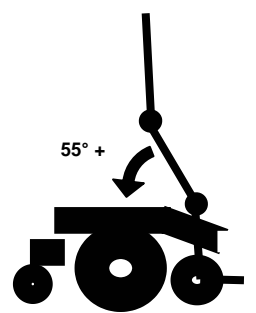

Chair drives!

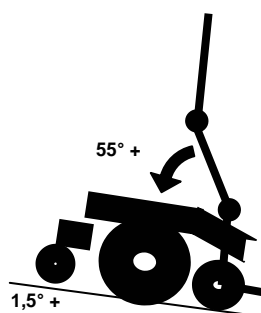

Gradient: Chair stops!  
Bring the seat in a lower position than 55°!

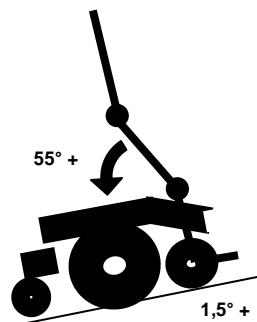

Slope: Chair drives!

The test (TUV, Germany) of the stability of the LEVO *combi* while not in motion proved the following results:

Sitting position facing downhill	12,5 degree
Standing position facing downhill	10 degree
Sitting position facing uphill (front wheels not touching the ground at the max., but still 100% of stability)	18 degree
Sitting position crossways direction	16 degree
Sitting position 45° to the horizontal direction	9 degree

Always approach small obstacles such as dropped curbs, ruts and thresholds at right angle. Always drive over obstacles slowly to avoid jolting or tipping. The LEVO *combi* has a curb climbing ability of maximum 6 cm / 2,4" being in a sitting position and 4 cm/1.6" being in an upright standing position.

Prevent the risk of overheat. Do not strain your motor too hard. Take care when climbing steep slopes at full speed for a far distance.

**Warning:** Never drive the wheelchair in the standing position outdoors or over obstacles. Please be attentive and always face ahead while driving. Watching what is going on around you with concentration leaves you enough time to react in case of an unexpected obstacle. Taking care like that helps to avoid accidents. Please watch for passengers, children, dogs and so on close to you and ahead of you because they intend to stop or change direction unexpectedly.

Never switch off the joystick module while driving the wheelchair. If you do, the wheelchair will stop instantly and there is a danger of being thrown out of the wheelchair. Always let go of the joystick and the wheelchair will stop smoothly.

If you think that you cannot find a maximum speed control setting that suits you, the control system can be programmed to meet your needs.

**Warning:** Programming should only be conducted by healthcare professionals within depth knowledge of Penny&Giles electronic control systems. Incorrect programming could result in an unsafe set-up of a wheelchair for the user. LEVO AG accepts no liability for losses of any kind if the drive or stability characteristics of the wheelchair are altered without prior notification and discussion with LEVO AG.

**Important:** Please ask for the regulations of your country considering the admittance for the usage of the roads regarding the wheelchair as a vehicle taking part of the traffic. These regulations vary in each country.

#### 14. Motor solenoid brakes

The wheelchair is fitted with automatic solenoid brakes on each motor. These brakes operate automatically whenever the joystick is moved. To put the brakes on simply let go of the joystick. The brakes also come on automatically when the joystick module is switched off.

**Caution:** To guarantee the function of the automatic motor brakes it is absolutely necessary to put the motor disengaging lever to the ON position. For more information please consult sector 15 about the free wheel device and the motor disengaging lever.

## 15. Free wheel device / Motor disengaging lever



For driving the wheelchair using the motor pull the motor disengaging lever out and turn it simultaneously to the ON position (A). (See picture 28a).

In this position the brakes are on until the joystick is moved.

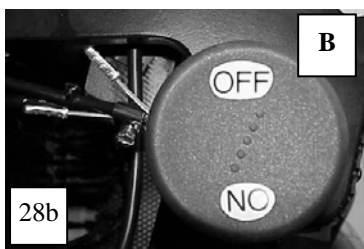

The wheelchair can be pushed when the free wheel device is not locked. Pull the motor disengaging lever out and turn it simultaneously to the OFF position (B). (See picture 28b).

**Caution:** In this position the brakes do not function.

When pushing the wheelchair avoid steep curbs, slopes or flights of steps because of the danger of losing your grip on the chair or of the occupant being tipped out. Always use a ramp or lift if available.

**Warning:** Never leave the wheelchair unattended with the motor disengaging lever on the OFF position. There would be a risk of the wheelchair running away. If the wheelchair starts to run away immediately turn the lever half way around the way that ON is at the upper position. This will stop the wheelchair immediately.

## 16. Batteries

The LEVO *combi* is supplied with maintenance free, dry rechargeable batteries of the type "Sonnenschein" A 512/55.0 A. They do not require any maintenance by the user other than regular charging.

### 16.1. Charging the batteries

The LEVO *combi* is supplied with a 24 Volt automatic battery charger type G2-300 which is easy to operate.

Charge the batteries at a time convenient to you. We suggest overnight. It is recommended to charge for 16 hours.

Always charge the batteries when the battery indicator on the joystick module is showing one bar lit. It is recommended to charge as often as possible.

Also if you are not going to use your wheelchair for some time charge the battery before storing the chair and at intervals of 4 weeks for 24 hours while the chair is being stored. Before using the chair again charge the batteries first for 24 hours.

**Notes:**

- The wheelchair cannot be driven when the charger plug is connected.
- The battery will not charge if the main switch on the battery box is switched off (see sector 10)

To charge the battery, insert the small round plug on the lead from the battery charger into the socket beneath the front of the joystick module. Plug in the mains plug.

The battery charger has four indicator lights.



LED1 (green): This lights up to show the battery is connected to the mains.

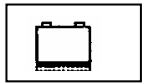

LED 2 (yellow): This lights when charging commences and blinks when the battery charged to 90%.

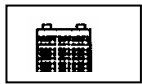

LED 3 (green): This lights up to show that the battery is fully charged and the charger is switched into the equalizing phase. Simultaneously LED 2 switches off.



LED 4 (red): If this lights up the battery is connected in reverse polarity. Disconnect the mains supply immediately and contact your local agent for advice.

To disconnect the charger, unplug the main plug then remove the small round plug from the wheelchair joystick module.

The battery can be left on charge indefinitely. The batteries will not be overcharged.

Allowing the batteries to deep discharge will damage them. If a deep charge occurs charge the battery as soon as possible for 24 hours. Always take every opportunity to charge them, this will considerably extend their lifetime.

## 17. Attendant instructions

### 17.1. Motor brakes

Always make sure the motor disengaging lever is in the ON position (motor brakes activated) when helping the user to get into or out of the wheelchair or when leaving the user unattended. For more information about the motor disengaging lever consult sector 15.

### 17.2. Lifting & general safety

- Never try to lift the wheelchair when the user is sitting in it.
- For your own safety never lift the empty wheelchair by yourself. Because of the weight and size of the wheelchair two people must lift it. It helps if you remove the footrests, backrest/headrest and batteries before lifting.

### 17.3. General safety

The wheelchair is designed to be used by one person only. Never allow children to play on the wheelchair or stand on the footrests or battery cover plate.

## 18. Cleaning

- Whenever the wheelchair gets dirty it should be cleaned using a damp cloth and then dried thoroughly.
- For more stubborn stains wipe with a damp cloth using a mild solution of warm water and a mild cleansing agent.
- Never use furniture polish, spirit or solvents to clean the frame.

## 19. Maintenance

### 19.1. Motor brakes

The LEVO *combi* is designed to be maintenance free and apart from the items below does not require attention from the user. Please note that to maintain safe and efficient operation the wheelchair should be serviced at least once per year by your LEVO agent or authorized dealer.

The user or their family can easily carry out the following tasks.

- Keep the wheelchair clean.
- Never store the wheelchair when damp.
- Keep the batteries charged to the maximum.
- Check if all fittings, harness, etc. are working properly (see section 6. - 8.).
- Check operation of motor disengaging lever weekly.
- Check operation of all controls daily.
- If any faults are found, report them immediately to your agent. He will advise you whether to continue using the wheelchair or not, and what action you should take to repair the wheelchair.

### 19.2. Spare parts

LEVO AG delivers single parts or modules as spare parts. Your distributor can provide all spare parts listed for your LEVO *combi*. You have also the opportunity to order a spare part list from LEVO AG directly.

## 20. Transporting your wheelchair

(This sector will be completed with information and instruction about the handling of the LEVO *combi* considering transportation.)

The LEVO *combi* has to pass the Crash Test. The information regarding this sector will be based on these results.

## 21. Disposal

Return the wheelchair after the product lifetime to the sales point. The dealer will dispose of it according to local regulations. Regarding the possibilities for individual adjustments your LEVO *combi* might be of use to another stand-up wheelchair user.

Return old batteries to the sales point of the wheelchair or of the new batteries. The dealer will dispose of them according to local regulations.

## 22. Trouble shooting

If you have problems with your wheelchair check this list before calling your local agent.

ITEM	PROBLEM	SOLUTION
Joystick module	Battery level indicator does not light	<ul style="list-style-type: none"> <li>• Switch on ON/OFF switch</li> <li>• Switch on safety cut out</li> <li>• Unplug charging plug</li> <li>• Replace battery</li> <li>• If above does not work consult LEVO agent</li> </ul>
	Battery level indicator flashes slowly	<ul style="list-style-type: none"> <li>• Charge Battery</li> </ul>
	Battery level indicator blinks every 2.5 Seconds	<ul style="list-style-type: none"> <li>• Joystick module in sleep mode. To restart switch off then on again.</li> </ul>
	Battery level indicator flashes rapidly	<ul style="list-style-type: none"> <li>• See section 23 below</li> </ul>
Driving	Will not drive in a straight line	<ul style="list-style-type: none"> <li>• Consult LEVO agent</li> </ul>
	Motors turn and battery level indicator lights up but chair does not drive	<ul style="list-style-type: none"> <li>• Make sure motor disengaging lever is pushed fully forwards.</li> <li>• Charge batteries</li> </ul>
	Motors do not turn but battery indicator lights	<ul style="list-style-type: none"> <li>• Charge batteries</li> <li>• On steep slope, set speed at max.</li> <li>• Consult LEVO agent</li> </ul>
Stand up Mechanism	Mechanism does not respond	<ul style="list-style-type: none"> <li>• Select stand-up mode on the joystick module</li> <li>• Charge batteries</li> <li>• Consult LEVO agent</li> </ul>
Battery charger Type G2-300	LED 1 does not light	<ul style="list-style-type: none"> <li>• Plug in main plug</li> <li>• Check household fuse</li> </ul>
	LED 1 lights but no other LED lights up	<ul style="list-style-type: none"> <li>• Consult LEVO agent</li> </ul>
	LED 1 lights, LED 2 flashes immediately	<ul style="list-style-type: none"> <li>• Check charging plug is inserted</li> <li>• Check safety switch is on</li> <li>• Consult LEVO agent</li> </ul>
	LED 1 lights, LED 2 continues flashing after lengthy period of charging (> 16 h)	<ul style="list-style-type: none"> <li>• Replace battery</li> <li>• Consult LEVO agent</li> </ul>
	Red Polarity lamp lights	<ul style="list-style-type: none"> <li>• Unplug charger immediately</li> <li>• Consult LEVO agent</li> </ul>



### 23. Controller self help guide

The battery indicator provides information in case a fault occurs to the wheelchair's electrical system. An appropriate number of lights flash rapidly on the display for a particular fault. Please see below.

If the fault is not corrected after following the recommended action, please contact your local agent for advice.

Lights Flashing		
10 green	High battery voltage	An excessive voltage has been applied to the control system. This is usually caused by a poor battery connection. Check battery and power module connections. If the fault remains contact your local agent.
9 green	Solenoid brake fault	The parking brakes have a bad connection. Make sure all connectors are plugged in properly. If the fault remains contact your local agent.
8 green	Possible power module fault	A Power Module fault is indicated. Make sure all the power module connections are pushed in properly.
7 yellow	Possible joystick module fault	A joystick fault is indicated. Make sure the joystick is in the rest position before switching on.
6 yellow	Charger connected	The battery charger is plugged into the wheelchair. Unplug the charger from the joystick module.
5 yellow	Right motor wiring fault	The right-hand motor has a short circuit to a battery connection. Contact your local agent.
4 yellow	Right motor disconnected	The right-hand motor has a bad connection. Make sure the motor connector is plugged in properly.
3 red	Left motor wiring fault	The left-hand motor has a short circuit to a battery connection. Contact your local agent.
2 red	Left motor disconnected	The left-hand motor has a bad connection. Make sure the motor connector is plugged in properly.
1 red	Low battery voltage	The battery needs charging or there is a bad connection in the battery. Check connections to the battery, power module (on front of battery box) and joystick module.

Please contact your local specialist in case you followed the advices but the problem still exists. Please provide your specialist with the serial number of your LEVO *combi* which is noted on the warranty card. This number might be important in case of questions to the manufacture company LEVO AG.

## 24. Technical information

Model	S-M		L-XL	
Wheelchair category	B			
Seat width	38 / 44 / 50 cm; 15 /17/20"			
Seat depth adjustable (incl. leg protector)	36 - 47 cm; 14 – 18,5"		47 - 58 cm; 18,5 – 23"	
Seat height (from top of cushion)	56 - 71 cm; 22 – 28"			
Armrest height (from top of cushion)	11 - 27 cm; 4 – 11"			
Footrest height (from top of cushion)	37 - 58 cm;14,5 – 23 "			
Footrest	height and angle adjustable			
Back height (incl. standard back upholstery)	43 cm; 17"			
Overall width	66 cm; 26"			
Overall length	110 cm; 43"			
Smallest turning circle	110 cm; 43"			
Type of tire	breakdown safe, without air			
Size of tire	front 8"	middle 1"	back 7"	
Overall height (incl. standard back upholstery)	89 – 104 cm; 35 – 41"			
Speed	0 – 10 km/h / 6mph			
Range (55 Ah batteries)	35 km; 22 miles			
Max. gradient (sitting position)	10°			
Max. gradient (standing position)	3°			
Kerb climbing ability (sitting position)	6 cm; 2,4"			
Kerb climbing ability (standing position)	1 cm; 0,4"			
Measurements LxWxH (no back system included)	93 x 66 x 67 cm; 36x26x26,5"			
Max. weight	170 kg; 375 pounds			
Max. total load	120 kg; 265 pounds			
Batteries	55 Ah			
Battery charger	type G2-300, 24 V DC			
Joystick module	Penny and Giles Pilot +			
Programming of driving characteristics	Standard for trained	Classic for new comer		Fun for experts
Colour	standard: red, yellow, blue, platinum, black			
	optional: metallic colours yellow, red, blue, silver	optional: 184 other colours of the RAL-offer	optional: 5 different reflex colours (turquoise, orange, lemon, white, silver)	optional: chrome

# **LEVO *combi & combi JR***

## **SERVICE MANUAL**

**This manual is for use by LEVO AG agents or their authorised dealers.**

**Read these instructions before servicing the wheelchair.**

**This service manual must be read in conjunction with the user manual.**

**Alterations in constructional and technical manner or to the electronic require the written authorisation of LEVO AG, otherwise no warranty or product liability will be accepted.**

## **1. Introduction**

Apart from regular charging of the batteries and keeping the wheelchair clean the LEVO *combi* is maintenance-free and no attention is required by the user.

Because of the complexity of the wheelchair the LEVO agent or authorised dealer should carry out a safety check at least once per year.

This service manual is to be used by the LEVO agent or authorised dealer. The manual gives information on how to perform a safety check and carry out repairs to the LEVO *combi*. This manual provides a good service to the persons in charge of the maintenance of the LEVO *combi*. And of course, the user appreciates the safety and the reliability of a well maintained wheelchair.

This manual must always be read and used with the user manual.

## **2. Health & safety**

Accidents do occur. When working on or testing the wheelchair be aware of the dangers and take care to ensure your own and other peoples health and safety.

## **3. Adjustments**

The majority of the adjustments can be carried out by the user or his family and are covered in the instruction manual. However, the LEVO agent should always, on delivery, adjust the wheelchair to suit the user.

### **3.1. Seat depth**

The adjustment of the seat depth should only be done by the LEVO agent or authorised dealer. For information consult the user instruction manual at section 7.1.

### **3.2. Low shearing at the back**

The adjustment of the low shearing at the back should only be done by the LEVO agent or authorised dealer. For information consult the user instruction manual at section 7.5.

### **3.3. Adjustment of the backrest**

The adjustment of the backrest should only be done by the LEVO agent or authorised dealer. For information consult the user instruction manual at section 7.6. and 7.7.

### **3.4. Electronic control system**

The preset settings are chosen to ensure safe operation. The settings are in compliance with all relevant legal requirements regarding the entire operating range of the joystick and the speed

control. In case the preset settings don't meet the needs of the user, the control system can be programmed individually; the maximum speed might be decreased for example.

**Warning:** Programming should only be conducted by healthcare professionals with in-depth knowledge of Penny&Giles electronic control systems. Incorrect programming could result in an unsafe set-up of a wheelchair for the user. LEVO AG accepts no liability for losses of any kind if the drive or stability characteristics of the wheelchair are altered without prior notification and discussion with LEVO AG.

It is in the responsibility of the person programming the control system to make sure that the stopping distance requirement specified for the country in which the wheelchair will be used is satisfied. If the braking rate is low, the forward and reverse maximum speed settings may need to be re-programmed. It is in the responsibility of the person programming the control system to make sure that the settings are safe and to note any programming changes made.

#### **4. Repairs: general instructions**

Only a LEVO agent or their authorized dealers should carry out servicing and repairs to the LEVO *combi*.

- Repairs: For advice in all repairs in Switzerland contact LEVO AG, Switzerland. For all other countries contact your local LEVO agent. Addresses are given at the front of this service manual.
- Major repairs: For all major repairs, e.g. bent or damaged frame, always replace complete components. Never try to repair damaged steel work or components.
- Replacement parts: Factory replacement components should be used in all repairs, these are available from LEVO AG. To order parts see the parts list drawings and the correlative list, both available at LEVO AG.

#### **5. Tools & torque settings**

The following tools are required to service the wheelchair:

- Spanners and sockets: 8 mm through to 24 mm.
- Hexagon key: 2 mm through to 8 mm.
- Screwdrivers: 1 Nm through to 50 Nm.
- Phillips head screwdriver and slotted screwdriver
- Soft headed hammer
- Snap through tool

Torque settings:

<b>Bolt size</b>	<b>Torque Nm</b>
M4	3
M5	6
M6	10
M8	25
M10	50

## **6. Important points**

- Do not reuse nuts. Always replace with a new nut.
- Always use thread locking compound.
- Always use recommended components and parts available from LEVO AG.
- Do not modify or repair the frame.
- LEVO AG is responsible for any repairs on gas springs, motors and electronic parts.

## **7. Recommended safety checks**

The following safety checks should be carried out at least once per year. This should be done by a LEVO agent or authorized dealer. If a fault is found do not allow the wheelchair to be used until it has been corrected.

1. Make sure that the backrest, options and additional material is fixed safely. Using a V-Trak backrest system check the lever of the backrest. All levers have to be completely pushed down. Repair any fault found immediately.
2. Examine the wheelchair frame for any damage. Replace any damaged or faulty components.
3. Examine the condition of the seat cushion and the backrest cover (standard version), respectively the therapod back shell cover (V-Trak backrest system) and replace if necessary.
4. Examine condition of all harnesses, straps and buckles and replace if necessary.
5. Examine and operate the footrest mechanism. Replace any damaged or faulty components.
6. Examine nuts, bolts, pivots and frame plugs for tightness and general condition. Replace any faulty components.
7. Examine the rear wheel, the front wheels and their castors for free rotation and security. Optimize the rotation and repair any fault found.
8. The tires are maintenance-free besides occasional cleaning. Use a damp cloth for cleaning. Tires must get replaced when the tire's profile is worn down. (For more information please consult sector 8.1. to 8.4.).

9. Check the free wheel device and the motor disengaging lever for correct operation. Repair any fault found.
10. Check the mechanical function of the motor disengaging lever. Pull the motor disengaging lever out and turn it simultaneously to the OFF position. At this stage it should be possible to push the wheelchair. Pull the motor disengaging lever out and turn it simultaneously to the ON position to activate the motor brakes. The power wheel should be blocked now. In case the power wheels are not completely blocked, it is absolutely necessary to replace the motor.
11. Check the powered function of the motor disengaging lever. Switch on the joystick module and start driving forwards. Let of the joystick. As a reaction the wheelchair should stop and the solenoid brakes of the motor should snap in evidence. Repeat this check driving backwards and to each side. In case the motor brakes don't function correctly check the battery indicator on the joystick module for any failure indication. Consult the controller self help guide (user manual sector 23) for details about failure indications.
12. Make sure all the connectors are properly inserted, that the brake solenoids are energized and that the solenoid coil is not open or short-circuited by testing the two bigger pins on the motor lead plug. If necessary, replace the motor.
13. Check all electrical cables and wires for chafing and clamp spots. Replace if necessary.
14. Check all electrical connectors for corrosion and security. Replace if necessary.
15. Clean the batteries and terminals. Test the battery capacity and advise the customer of their condition. Charge the batteries before returning the wheelchair to the customer.
16. Check all MODE functions as standing-up and sitting as well as the optionally added functions (lift, backrest reclining, seat tilt, lying to standing directly). Repair any fault found.
17. Check all lights and indications. Replace components with failures.
18. Use all functions and drive the wheelchair as a final check. In case you notice any kind of problems arrange the fixing.

## 8. Repairs

### 8.1. Replacing the drive wheels

When removing a wheel, the wheelchair must be unoccupied. The wheelchair must be supported (B) so that it neither falls over or moves when a wheel is removed.

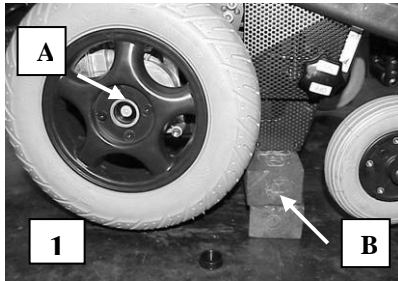

- Pull off the protective end cap which covers the countersunk screw.
- Remove the countersunk screw (A) using a 5 mm hexagon key.
- Remove then the black washer (F, picture 2).
- Withdraw the wheel from the wheelchair.
- To mount the new wheel follow the instructions in the reverse order.

### 8.2. Replacing the tire of a drive wheel

When replacing the tire, means removing a wheel, the wheelchair must be unoccupied. The wheelchair must be supported so that it neither falls over or moves when a wheel is removed.

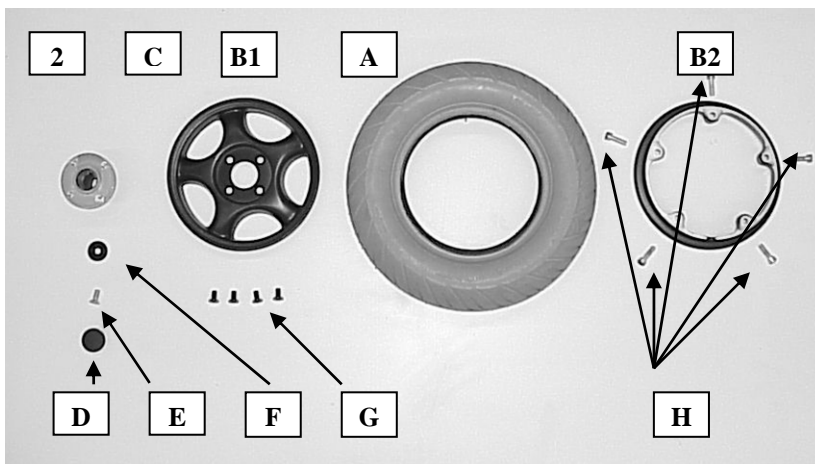

- Remove the drive wheel as described in sector 8.1.
- Remove the four black countersunk screws (G) to take the flange (C) of the wheel using a 5 mm hexagon key.
- Remove five screws (H) of the rim using a 6mm hexagon key.
- Withdraw the rims (B1 and B2) from the tire (A).
- Reassemble in reverse order.
- To fit the rims to the tire use gunk to make it easier.
- **Important:** Take note of the circulation direction indicated on the tire before fixing.



### 8.3. Replacing the front wheels

When removing a wheel, the wheelchair must be unoccupied. The wheelchair must be supported so that it neither falls over nor moves when a wheel is removed.

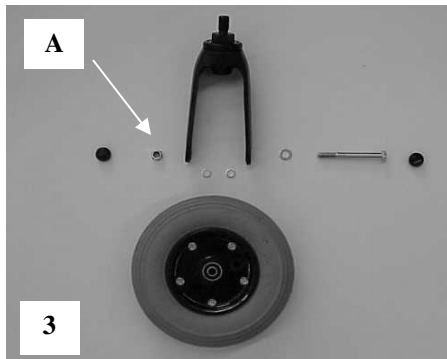

- Pull off the protective end caps from the axle.
- Loosen the hexagon screw and washer using a 13 mm hexagon key and remove the screw, the washer and the nut (A).
- Withdraw the wheel from the fork.
- Reassemble the new wheel in reverse order.
- Make sure all washers are placed correctly!

### 8.4. Replacing the back wheel

When removing the wheel, the wheelchair must be unoccupied. The wheelchair must be supported so that it neither falls over or moves when the wheel is removed.

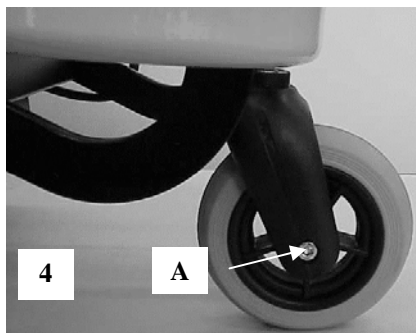

- Loosen the screw (A) using a 6 mm hexagon key and remove the screw, the washer and the nut.
- Withdraw the back wheel from the fork.
- Reassemble the new wheel in reverse order.
- Make sure all washers are placed correctly!

### 8.5. Replacing the wheel fork (at front and back)

When removing a wheel and/or a wheel fork, the wheelchair must be unoccupied. The wheelchair must be supported so that it neither falls over nor moves when a wheel is removed.

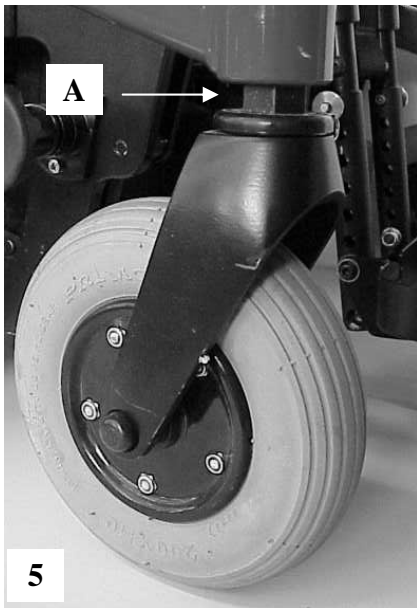

- Loosen the hexagon spike (A) at the wheel fork axle as much as it needs to withdraw the fork from the mount. (Use a 24 mm hexagon key.)
- Replace the wheel fork.
- Reassemble the used wheel in case it is still in a good condition. Doing so please follow the instruction in sector 8.3. respectively 8.4.
- Mount the new wheel fork in the reversed order.

(Picture 3 shows all parts in details.)

### 8.6. Replacing the connector of the back low shearing system

As a standard a connector of medium size is fixed. The shearing range regarding the back movement is 9 cm / 3,5". The replacement of this connecting piece using a shorter or a longer piece causes a variation of 8 cm / 3" respectively 10 cm / 4" of the shearing range.

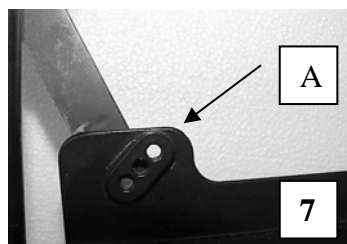
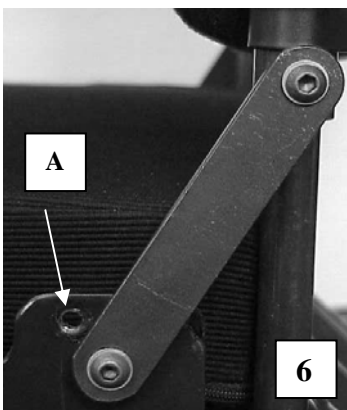

- Raise the seat to its maximum upright standing position.
- Switch off the joystick module.
- Loosen the fillister head screw at the backrest tube as well as the double-head screw at the seat plate using a 4 mm hexagon key.
- Remove the mentioned screws, the washers and the connector.
- First mount the upper end of the new connector at the backrest tube. Make sure to put the two washers back in place.
- After that mount the lower end of the new connector at the seat plate using the corresponding punched hole (A on picture 6 and 7). Again make sure to put the two washers back in place.

### 8.7. Replacing the motor disengaging cable (free wheel device)

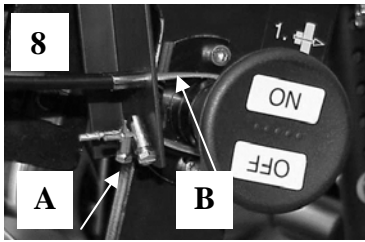

- Raise the seat to its maximum upright standing position.
- Switch off the joystick module.
- Remove the cover of the motor loosening both screws using a 4 mm hexagon key.

#### Right hand side motor disengaging cable

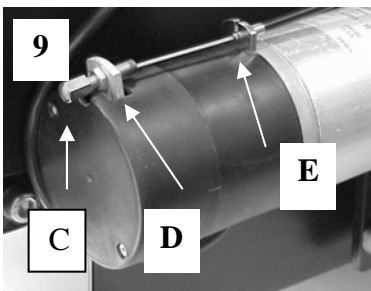

- Cut the right hand side motor disengaging cable (B) from the cable clamp (A). (See picture 8).
- Withdraw the motor disengaging cable backwards.
- Make sure the motor disengaging lever is at the ON position.
- Lead first the new motor disengaging cable through the adjusting screw (C). The nut (D) should be centred at the adjusting screw (C).
- Lead then the cable through the hole of the disengaging motor and through the other hole in the metal piece (E) on the motor.
- Lead further the cable through the cable jacket and around the disengaging shaft.
- Adduct the cable that a slight tension occurs. The cable should not escapade of the disengaging shaft spline.
- Tighten the pen headed slotted screw around the cable clamp using a slotted screw driver.

#### Left hand side motor disengaging cable

- Cut the left hand side motor disengaging cable (B) from the cable clamp(A)(See picture 8)
- Withdraw the motor disengaging cable backwards out.
- Make sure the motor disengaging lever is at the ON position.
- Lead first the new motor disengaging cable through the adjusting screw (C). The nut (D) should be centred of the adjusting screw (C).
- Lead then the cable through the hole of the disengaging motor and through the other hole in the metal piece (E) on the motor.
- Lead the cable through the small tubes at both side of the battery box.
- Lead further the cable through the cable jacket and around the disengaging shaft.
- Adduct the cable that a slight tension occurs. This cable should not escapade of the disengaging shaft spline.
- Tighten the pen headed slotted screw around the cable clamp using a slotted screw driver.
- First controlling: turn the motor disengaging lever to the OFF position and check if the motor is unlocked. In case it is not unlocked turn the nut (D) on the adjusting screw (C) forwards as far as it needs to unlock the disengaging motor, the lever set on the OFF position.
- Second controlling: turn the motor disengaging lever to the ON position and check if the motor is locked. In case it is still unlocked turn the nut (D) on the adjusting screw (C) backwards as far as it needs to lock the disengaging motor, the lever set on the ON position. Shorten the end of the cable at 15 mm and clamp the cable end-protector piece.
- Fix the motor cover in the reverse order.

## 8.8. Replacing the driving motor

When removing the driving motor, the wheelchair must be unoccupied. The wheelchair must be supported so that it neither falls over or moves while replacing the driving motor.

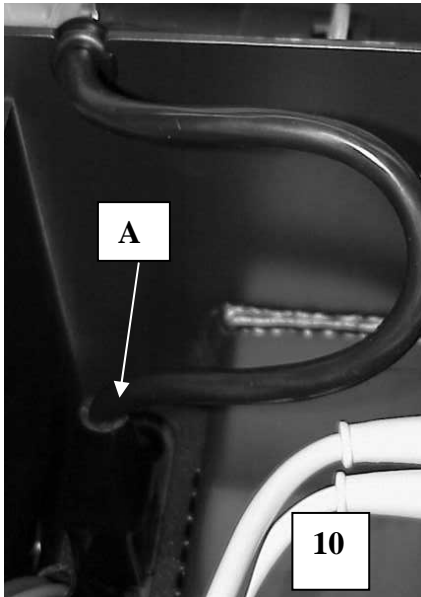

- Switch off the safety cut-out.
- Open the cover of the battery box and disconnect the motor plug (A) from the power module.
- Remove first the drive wheel as described in sector 8.1.
- Remove the motor cover loosening the screws using a 4 mm hexagon key.
- Loosen the motor disengaging lever cable.
- Now loosen the four cylinder head screws (B) at the motor using a 6 mm hexagon key.
- Mount the new motor with the four cylinder head screws (B) using the 6 mm hexagon key again.
- Fix the disengaging motor cable as described in sector 8.7.
- Reassemble the motor cover.
- Mount the drive wheel in the reverse order.
- Connect the motor plug to the power module.

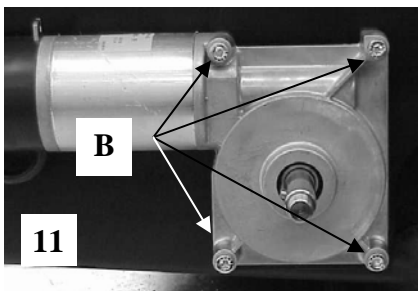

## 8.9. Replacing the batteries

**Caution:** The battery box is heavy, take care when lifting and carrying.

**Caution:** When working on the batteries take great care not to short out the terminals with any metal tools etc. Always remove wristwatches or jewelry. When reconnecting make sure all wires are connected to the correct battery terminals.

**Caution:** Contact with acids is dangerous. If you come into contact with acids, rinse the contaminated body parts immediately with water and consult your doctor. Take off immediately using acid contaminated clothing.

**Caution:** Always wash your hands after working on the batteries.

- If possible, raise the seat to the fully upright position.
- Switch off the safety cut-out.
- Open the battery cover.
- Loosen the screws at the electrical contact of the batteries using a 13 mm screw wrench and remove the small metal terminal piece (A).

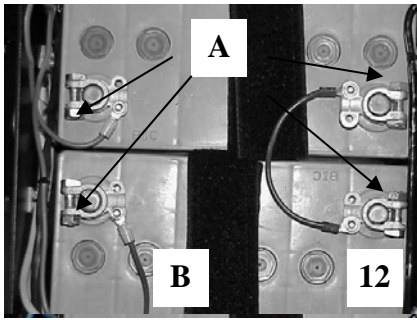

- Lift the batteries out of the battery box.
- Put the new batteries in the battery box.
- Reassemble in the reverse order.

The batteries should always be replaced as a complete set.

### 8.10. Replacing the joystick module

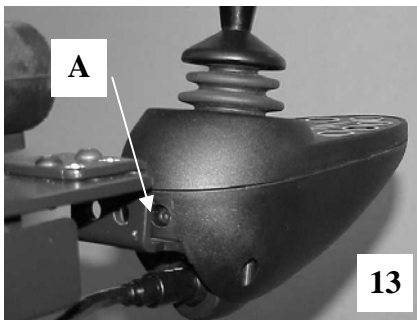

- Switch off the joystick module.
- Unplug the joystick cable at the back of the joystick module.
- Loosen the two hexagon screws (A) at the back of the joystick module using a 3 mm hexagon key and remove them.
- Lift the joystick module.
- Mount the new joystick module in the reverse order.

### 8.11. Replacing the power module

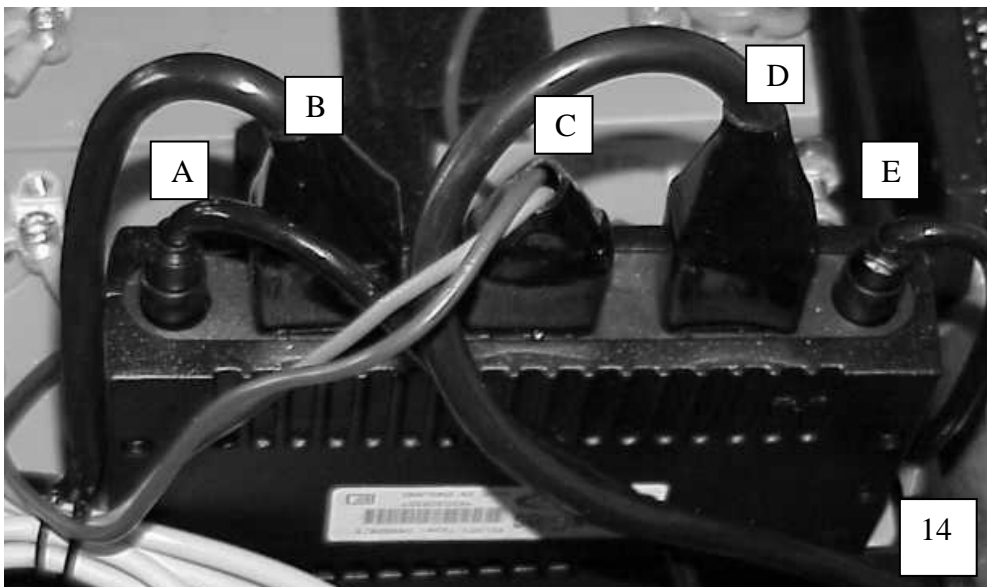

- Raise the seat to its maximum upright standing position.
- Switch off the safety cut-out on the battery box.
- Open the cover of the battery box.
- Unplug the following connections:
  - ALM cable (A)
  - left motor cable (B)
  - battery cable (C), which is either red and black or red and blue

- right motor cable (D)
  - joystick cable (E)
- (all cables are listed from the left to the right hand side, see picture 14)

Please notice the interlocking of the different plugs:

- ALM and joystick plug: pull back the lock.
- Motor cable plug: press the release catch at both sides of the plug.
- Battery plug: press the release catch at the upper side of the plug.
- The power module is fixed with a Velcro fastener at the bottom of the battery box.
- Reverse the above to refit.

### 8.12. Replacing the ALM (Actuator-Lights-Module)

- Raise the seat to its maximum upright standing position.
- Switch off the safety cut-out.
- Open the cover of the battery box.
- Unplug the ALM cable of the power module pulling back the lock. (Consult sector 8.11. for more information).
- The ALM is fixed with a Velcro fastener at the bottom of the battery for keeping it in place while driving.
- Remove the ALM from the battery box.
- Disconnect the plugs at the connector.
- Connect the plugs of the new ALM along the scheme shown at the inside of the battery cover.
- Reassemble the new ALM in the reverse order.

### 8.13. Replacing the gas spring

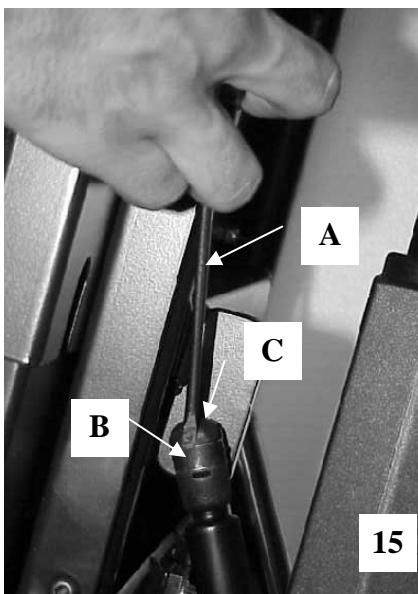

The gas spring serves for easy manual raising of the seat in case of any disorder considering of the batteries or the actuator "standing" and you still need access to the battery box in order of any repair.

The gas spring raises the seat and supports it in the standing position without the actuator "standing" in use.

- Raise the seat to the maximum standing position.
- Lift the clip (B) on the upper part of joint of the gas spring using a slotted screwdriver (A) and press the joint part off the joint pivot (C).  
**Caution:** Do not remove the clip!
- Lift the clip on the lower part of the joint of the gas spring using a slotted screwdriver and press the joint part off the joint pivot.  
**Caution:** Do not remove the clip!
- Remove the gas spring now.
- Mount the new gas spring in the reverse order pressing the ends on the correlative joint pivot.

#### 8.14. Replacing the actuator "standing"

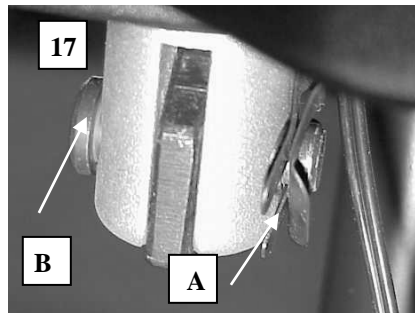
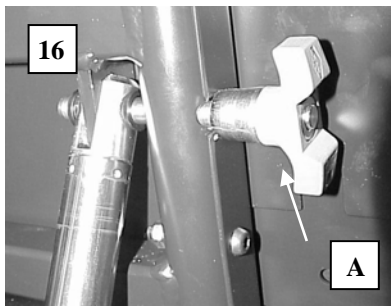

- Raise the seat to the upright standing position.
- Switch off the joystick module and the safety cut-out.
- Remove the quick-release axle (A, picture 16) from the upper end of the actuator.
- Push the seat further to the upright position as high as it needs to remove the actuator off the recess drilled into the seat support. In case the seat is already at the maximum standing position the gas spring has to be unfixed at the upper end. (Read the instruction in sector 8.13.)
- Remove the clip (A, picture 17) at the inside of the lower end of the actuator.
- Press out the spike (B, picture 17), use a hammer and a snap through tool to strike the spike carefully out of the rod.
- Unplug the actuator from the battery box and remove it.
- Reassemble the new actuator in the reverse order.

#### 8.15. Replacing the actuator "lift"

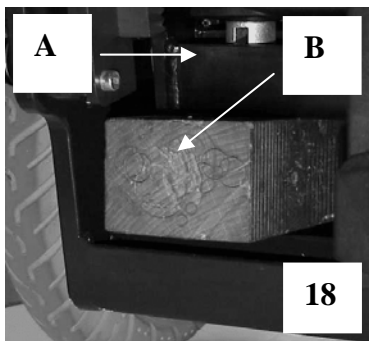

- If the chair is supplied with the relax/lying function as an option get the chair in the maximum lying position. It is hard access to the actuator "lift" if there is no such function added.
- Switch off the joystick module and the safety cut-out.
- Support the lower base of the yoke (A) using a log (B) or wooden rod that might be a broomstick for example to secure the lift from falling down. (See picture 18.)
- Unplug the actuator "lift" from the battery box.
- Remove the clip (A on picture 17) at the upper end of the actuator.
- Press out the spike (B on picture 17), use a hammer and a snap through tool to strike the spike carefully out of the rod.
- Remove the actuator from the upper end of the halter of the actuator.
- Detach the clip (A on picture 17) at the lower part of the actuator and remove the spike as described before.
- Now remove the actuator.
- Reassemble the new actuator "lift" in the reverse order.  
Take care that the piston rod of the new actuator is retracted (inside). Start work at the lower part of the actuator and connect the plug of the actuator at the battery box first. Retract the piston rod until it fits to the halter of the actuator "lift".

### 8.16. Replacing the actuator "lying"

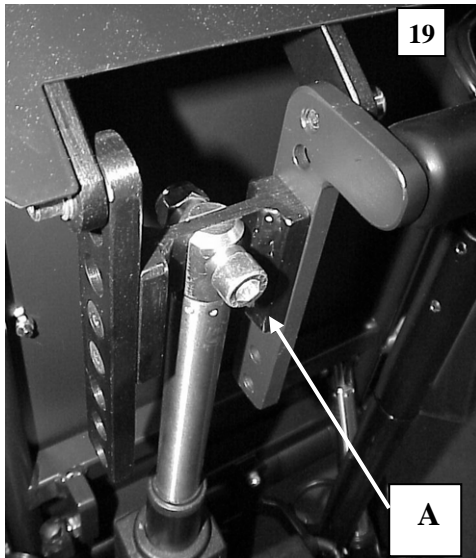

- Raise the seat to the upright standing position.
- Switch off the joystick module and the safety cut-out.
- Disconnect the plug of the actuator "lying" from the battery box.
- Loosen the screw (A on picture 19) using a 8 mm flat wrench.
- Remove the back end of the actuator from the connecting part.
- Remove the clip (A on picture 17) at the front end of the actuator.
- Press out the spike (B on picture 17), respectively use a hammer and a snap through tool to strike the spike carefully out of the rod.
- Press the front end of the actuator down and off the

halter. Pull it then to the front and off the back halter.

- Now remove the actuator.
- Reassemble the new actuator "lying" in the reverse order. Take care that the piston rod of the new actuator is retracted (inside). Start work at the front part of the actuator and connect the plug of the actuator at the battery box first. Retract the piston rod until it fits to the halter at the back.

### 8.17. Replacing the safety cut-out

To replace the safety cut-out the seat needs to be in the standing position for access to the safety cut-out and the battery box. In case the seat is locked in the sitting position or the safety cut-out is set in the OFF position, then the actuator "standing" has to be detached at the upper end and the seat has to be raised manually. (Consult sector 8.14 for instructions considering the detachment of the actuator "lying".)

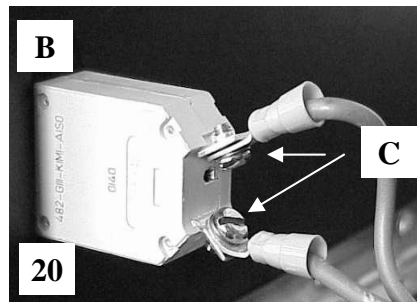
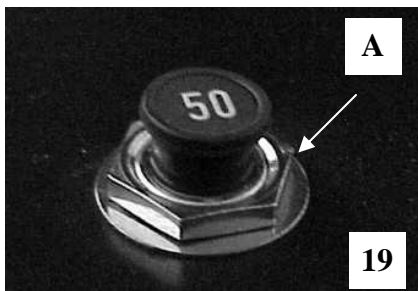

- Remove the nut (A) at the safety cut-out switch using a 14 mm slotted screw driver.
- Open the cover of the battery box.
- Disconnect both connectors at the safety cut-out (B) loosening two thross head screws (C) using a small slotted screw driver.
- Replace the safety cut-out in the reverse order.



## 8.18. Replacing bulbs

### **Important instructions for replacement of indicators, indicators and bulbs:**

**Caution: Always switch off the safety cut-out first before any part of the lighting system will be replaced or fixed.**

**Caution: Never touch a bulb at the glass casing with bare fingers. This effects the life time of the bulb most negatively.**

The LEVO combi is supplied with the following types of bulbs:

- lights in front, white 12V / 3W, screw thread E10
- indicators in front/back, orange 24V / 10W, bayonet fixing
- lights at the backside, orange 24V / 5W, stick lock

Replacement of the bulb in a light (front, white)

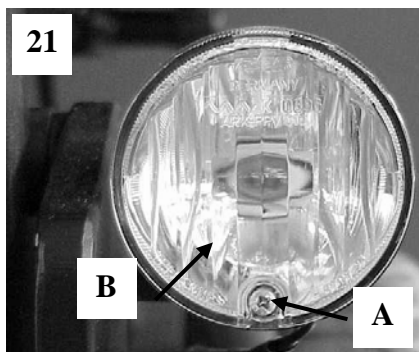

- Loosen the screw (A) using a small Phillips screwdriver and remove the white cover plate (B).
- Turn the bulb counter clock wise off the thread.
- Replace the bulb in the reverse order.

Replacement of the bulb in a indicator (front/back, orange)

- Loosen the screw using a small Phillips screwdriver and remove the orange cover plate.
- Press the bulb smoothly into the thread and turn it simultaneously counter clock wise off the thread.

Replace the bulb in the reverse order.

Replacement of the bulb in a light (back, red)

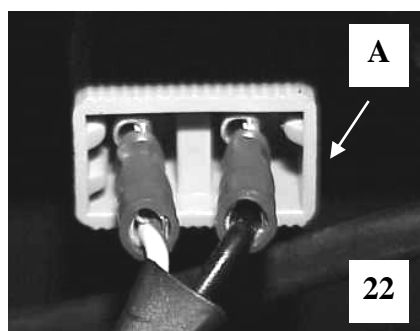

- Open the cover of the battery box.
- Turn the bayonet fixing (A) (the bulb is integrated in this part) counter clock wise and take it out of the casing.
- Remove the bulb from the thread.
- Replace the bulb in the reverse order.

### 8.19. Replacing the light (front, white)

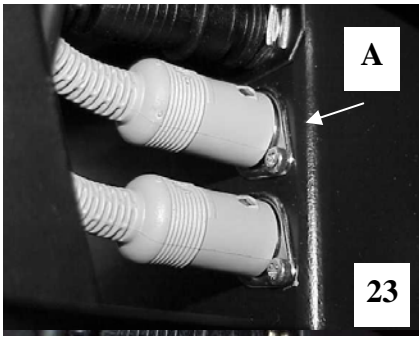

- Disconnect the light plug (A) from the battery box.
- Loosen the screws at the side using a 5 mm hexagon key for removing the white light (B).
- Loosen the Phillips head screw using the correlated screwdriver and remove the cover plate from the light (D).
- Pull the bulb thread carefully out to unplug the connectors.
- Remove the hexagon screw (C) including the serrated washer using a 5 mm hexagon key.
- Demount the lighth.
- Reassemble the new light in the reverse order.

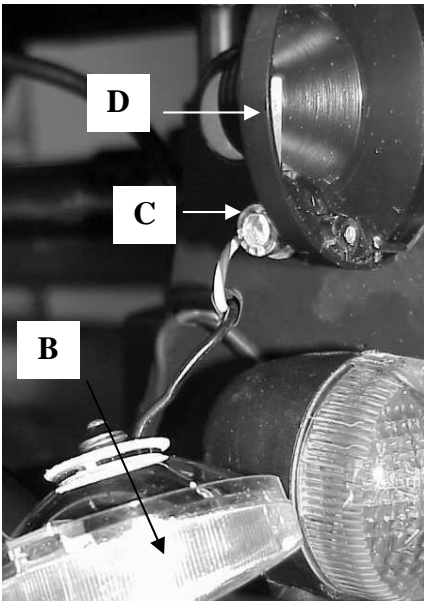

### 8.20. Replacing the indicator

#### Blinker at the back

- Open the cover of the battery box.
- Demount the bulb thread of the blinker.
- Unplug all connectors and pull back the cables to the battery box.
- Remove the indicator.
- Reassemble the new indicator in the reverse order.

#### Blinker at the front

- Loosen the screw at the cover plate of the indicator using a Phillips screwdriver and remove the cover plate.
- Loosen in the inside of the indicator casing the hexagon screw using the correlative 5 mm key.
- Remove the indicator from the base frame.
- Unplug all connectors.
- Reassemble the new indicator in the reverse order.

## **9. Testing the wheelchair**

Always perform full functional tests on the wheelchair when repairs have been completed and before it is returned to the customer. Only return the wheelchair to the client when all faults have been rectified.

## **10. Cleaning**

Before returning the wheelchair to the customer ensure the wheelchair is clean and well presented:

- If there is any dirt it should be cleaned off using a damp cloth and then dried thoroughly.
- For more stubborn stains wipe with a damp cloth using a mild solution of warm water and soap.
- Never use furniture polishes or spirit to clean the frame.

## 11. Technical information

### 11.1. Measurements (metric)

Model	S-M	L-XL
Seat width	38 / 44 / 50 cm	
Seat depth adjustable (incl. leg protector)	36 - 47 cm	47 - 58 cm
Seat height (from top of cushion)	56 - 71 cm	
Armrest height (from top of cushion)	11 - 27 cm	
Footrest height (from top of cushion)	37 - 58 cm	
Back height (incl. standard back upholstery)	43 cm	
Overall width	66 cm	
Overall length	110 cm	
Smallest turning circle (diameter)	110 cm	
Overall height (incl. standard back upholstery)	89 – 104 cm	
Speed	0 – 10 km/h	
Range (55 Ah batteries)	35 km	
Max. gradient (sitting position)	10°	
Max. gradient (standing position)	3°	
Kerb climbing ability (sitting position)	6 cm	
Kerb climbing ability (standing position)	1 cm	
Measurements LxWxH (no back system included)	93 x 66 x 67 cm	
Max. weight	170 kg	
Max. total load	120 kg	

## 11.2. Measurements (imperial)

Model	S-M	L-XL
Seat width	15 /17/20"	
Seat depth adjustable (incl. leg protector)	14 – 18,5"	14,5 – 23 "
Seat height (from top of cushion)	22 – 28"	
Armrest height (from top of cushion)	4 – 11"	
Footrest height (from top of cushion)	14,5 – 23 "	
Back height (incl. standard back upholstery)	17"	
Overall width	26"	
Overall length	43"	
Smallest turning circle	43"	
Overall height (incl. standard back upholstery)	35 – 41"	
Speed	6mph	
Range (55 Ah batteries)	22 miles	
Max. gradient (sitting position)	10°	
Max. gradient (standing position)	3°	
Kerb climbing ability (sitting position)	2,4"	
Kerb climbing ability (standing position)	0,4"	
Measurements LxWxH (no back system included)	36x26x26,5"	
Max. weight	375 pounds	
Max. total load	265 pounds	

### 11.3. General technical information

Drive wheels Tires	Diameter 350 mm x 70 mm; 14" x 2¾" No breakdown risk
Front wheels Tires	Diameter 200 mm x 50 mm; 8" x 2" No breakdown risk
Back wheels Tires	Diameter 140 mm x 40 mm; 5½" X 1½" No breakdown risk
Speed	0 - 10 km/h precision controlling (There exist regulations considering speed limits for wheelchairs in certain countries. These regulations have to be observed!)
Drive motor	4-PI 24 V DC, 350 W / Brakes: 12 V DC (Micro Motor)
Drive motor actuator	24 V DC, 350 W
Batteries 55 Ah	Maintenance-free lead accumulator in fleece technology 2 pcs. 12V / 55 Ah type "Sonnenschein" dryfit A 500 Size: 260x135x230 mm/pc., weight: 18 kg/pc. Max. discharge power for 6 minutes 72 A
Range	Approximately 35 km / 22 miles Note: Range is affected by the load carried, hills climbed and temperature.
Maximal tolerable gradient (static)	10° (25%)
Maximal kerb climbing ability	6 cm/2,4"
Charger	Typ G2-300 24 V DC The no-load voltage is 27.6 V, measured across pins 1 and 3 on the charging plug.
Maximal load including all objects carried along	120 kg/265 pounds
Wheelchair category	B

#### 11.4. Electromagnetic Interference (EMI)

We recommend to consult the sector 12 of the user manual for important information about electromagnetic interference.

##### Advice

Following the advice listed below should reduce the chance of unintentional brake release or powered wheelchair movement.

Do not operate hand-held transceivers (transmitters-receivers), such as citizens band (CB) radios.

Do not switch on personal communication devices, such as cellular phones, while the powered wheelchair is turned ON.

Be aware of any nearby radio or tv station transmitters and try to avoid going close to them.

If unintentional movement or brake release occurs, turn the powered wheelchair OFF as soon as it is safe to do so. Report all incidents of unintentional movement or brake release to the manufacturer, and note whether there was a radio wave source nearby.

Finally, be aware that adding accessories or components, or modifying the powered wheelchair, may make it more susceptible to EMI. LEVO AG cannot take any responsibility for the effects of EMI if your wheelchair has been altered in any way.