

Even our children can stand like giants

LEVO combi Jr

LEVO Stands for a better quality of life

LEVO combi
LEVO combi Jr

LEVO combi | The Mid-Wheel power wheelchair with stand-up function and complete seating systems

LEVO combi



simply attend to...

The powered LEVO combi Jr means secure and active support for your child. The extremely agile power wheelchair optimises participation into all of your child's opportunities and activities. School, Home, Play. Like the adult version, the LEVO combi Jr has multiple power seating systems including the LEVO designed and industry leading standing capability. (Your child can drive the LEVO combi Jr even while in the standing position.) Easy adjustable growth plates, components and a wide range of accessories and options let the LEVO combi Jr smoothly grow with your child for many years.



Highlights

- User-friendly, simple handling
- Smooth seat/standing positioning movement
- Compact manoeuvrability for tight spaces (turning circle 43 in)
- Safe and secure stand-up operation elevating to any and all angles between sitting and 85° standing
- Adjustable for upper and lower leg, foot position and back angle
- Max. user weight up to 265 lb
- Wide range and style of options, accessories and control switches
- Multiple colour options
- Easy accessibility for maintenance and service updates
- Certificates: TÜV, CERAH, HI, FDA/510(k), Crash Test

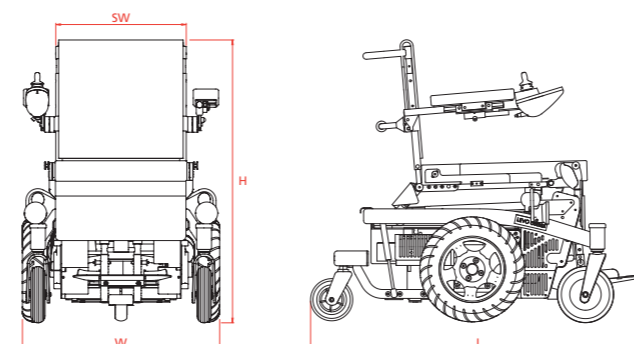

Technical Data

Model	combi		combi/Jr
	S-M	L-XL	XS-S
Seat width (SW)	15/17.3/19.7		11.8/13.8/15
Total width (W)	26		26
Total length (L)	43.3		43.3
Total height (incl. Backrest upholstery) (H)	35-40.9		35-40.9
Seat height (with seat cushion)	22-27.9		22-27.9
Seat upholstery depth	11.4-16.5	15.7-20.9	9.4-12.2
Armrest height (from top of cushion)	6.7-9.8		5.9-13
Back height (with standard backrest upholstery)	16.9		16.9
Foot rest height (from top of cushion)	14.6-22.8		9-18.5
Turning circle	43		43
Speed	3,7/5/6,2 mph		3,7/5 mph
Range	22 miles		22 miles
Max. gradient	12° (25%)		12° (25%)
Kerb climbing ability	3.1		3.1
Max. chair weight	375 lbs		375 lbs
Max. user weight	265 lbs		265 lbs
Transport dimension	36.6 x 6 x 26 x 26.4		36.6 x 26 x 26.4

All measurements in inches and pounds. Discrepancies in the measurements may arise due to wheelchair modifications.

Standard Configuration

- Backrest upholstery
- Flip-up armrests, height adjustable
- Flip-up footrest
- Knee support and chest strap
- Length adjustable backrest and height adjustable armrest
- Manual seat height adjustment
- Powered stand-up function
- Powered driving in sitting and standing
- Powered lying/standing direct function if reclining option included
- Set of batteries and charger
- PGDT controller (P+/R-net)

Options/Accessories

- Swing away joystick
- Lights and indicators
- V-Trak back system
- V-Trak head and thoracic support
- Powered seat lift 5.9 in
- Powered reclining backrest/legrest 90-180°
- Foam seat cushion 2.4 in
- Assorted knee supports and footrest wedges
- Chest roll
- Table tray
- Skirt guard
- Vehicle tie-down kit
- Push handle bar
- ... many more on request

Colours

5 standard colours (blue, red, yellow, platinum, black) and 190 other colour options



Gerald Simonds Healthcare Ltd. 9 March Place, Gatehouse Way, Aylesbury, Bucks HP19 8UA
 Freephone: 0800 220975 Fax: 01296 380279 email: info@gerald-simonds.co.uk
 www.gerald-simonds.co.uk



LEVO stands for a better quality of life

LEVO.of
THE EXPERTS IN STANDING

At eye level with life

This is LEVO: The touch of a switch elevates you to a safe, comfortable standing position to interact with your active life. At work, in school or at home, LEVO standing wheelchairs offer exactly what you need: Independence, Mobility, Support, Health and Quality. Each wheelchair is designed with the experience of more than 30 years of research, development and client response. LEVO is proud to offer wheelchairs that combine seating and standing positions matched to your unique biomechanical dynamics with superior manoeuvrability, size, weight, aesthetics and adjustability. All models are reviewed and certified by internationally approved testing institutes.



LEVO combi



One wheelchair everywhere, every day

You need power mobility but you want a customised chair that fits into your everyday life and environment. Welcome to the LEVO combi mid-wheel power base: a design that maximises manoeuvrability, turning radius and overall traction for life's ups and downs. The seating system on the power base is the best combination of seated, stand and recline offered in the industry. You can even transition directly from full recline to full standing – smoothly, securely and

stop anywhere in between. In any position you can engage the world with power mobility – move, turn, reverse – all while in any of the multiple and customised seating positions that you choose for your chair. The LEVO combi easily manoeuvres within your home, your work. Indoors, outdoors, all while ensuring stability, safety, multiple seating and standing positions to enhance and extend quality of life.



Back and knee adjustment to reduce shear

Intelligent control system of PG-Drive Technology



Smallest turning circle thanks to the centre wheel drive

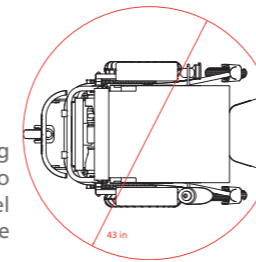

Seating/Standing

- Precisely engineered chair design for exceptionally smooth and low shear transition between all standing and seating functions
- Standing, seat- and back angle adjustment, seat lift, tilt, recline
- Customised match to individual body mechanics and chair design
- Numerous health benefits because of more frequent standing

Power base

- Compact size and weight with excellent power manoeuvrability, response and traction
- Centre wheel drive provides for the smallest turning circle (43 in)
- Stable and safe driving in seated or standing position (automatic program for controlled standing speed.)
- Safely and effectively climbs and descends ramps up to 12°
- Multiple programming options for maximum choice
- Whisper quiet drive and seating operation

Use the LEVO combi everywhere, every day



LEVO combi

LEVO combi Jr

The Mid-Wheel power wheelchair with stand-up function and complete seating systems for junior sizes

LEVO combi Jr



LEVO stands for a better quality of life