

e-motion®

M 12

Gebrauchsanweisung

Operating Instructions

Instructions d'utilisation

Manual de instrucciones

Istruzioni per l'uso

Brugsvejledning

Gebruiksaanwijzing

Bruksanvisning

Instruktionsbok

D

GB

F

E

I

DK

NL

N

S

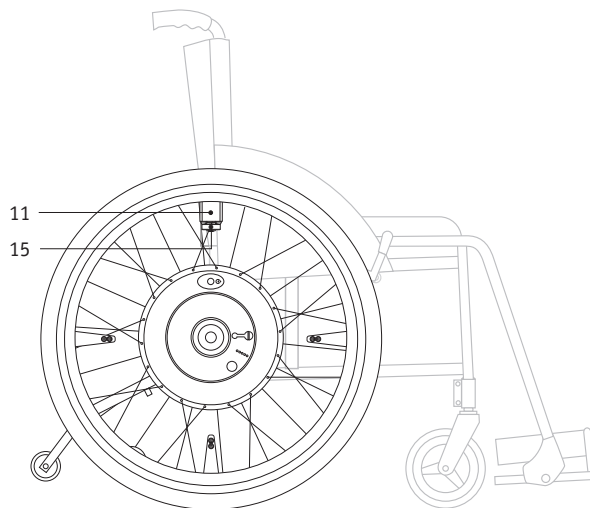
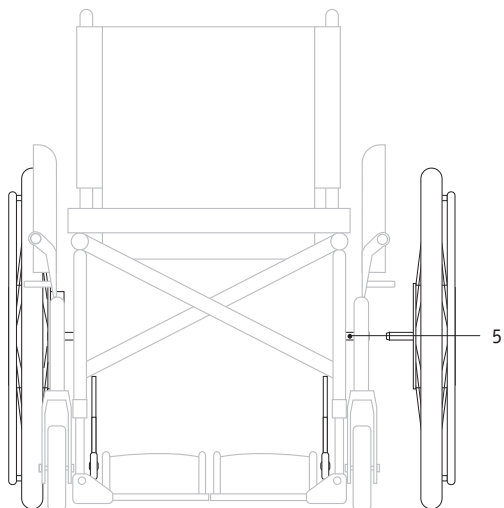
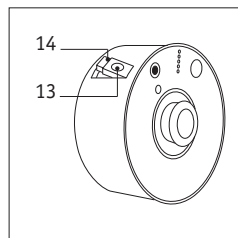
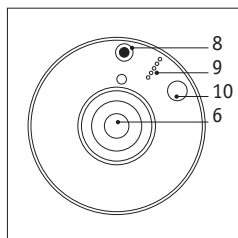
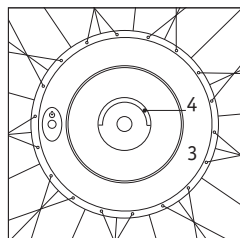
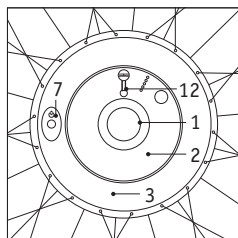

Table of Contents

1	Delivery Package, Standard	4	9.3	Storage and Transportation	16
2	Technical Data	5	9.4	Protection of the Socket	16
3	Wheels	6	9.5	Changing the Fuses	16
3.1	Holding Device for the Wheels	6	9.6	Recycling	17
3.2	Delivery of Wheels and Batteries	6	10	Removing the wheels, transport	17
3.3	Mounting the Wheels to the Wheelchair	6	11	Signal Codes	19
4	Inserting the Batteries	8	12	Instructions for driving the e · motion	20
5	Tilt Support	9	12.1	General instructions	20
6	Operation	12	12.2	Dangerous ground and dangerous situations	21
6.1	Turning On	12	13	Care	22
6.2	Turning Off	12	13.1	Maintenance	22
7	Levels of Power	12	13.2	Care of batteries	22
7.1	Power Survey	13	13.3	Corrosion information	23
7.2	Sensitivity Control	14	14	Service and Repair	23
8	Automatic Switch off	14	15	Recycling	24
9	Batteries	15	16	Warranty and Liability	24
9.1	Functions and Display	15	16.1	Warranty	24
9.2	Charging the Batteries	15	16.2	Liability	24
			17	Index	25

Dear wheelchair driver

With your decision to use the e·motion wheelchair power by **alber** you got yourself a tangible glimpse of the future and a great deal of personal mobility.

After the following brief information we will introduce you to the e·motion and its functions, but first we would like to explain the advantages of the system to you:

- absolutely noiseless technology, gearless and brushless engine
- next to no maintenance
- the level of power that supports you and the driving characteristics are individually adjustable to potential physical handicaps
- superior steering electronics cater particularly to driving a wheelchair
- driving downhill operates with electrically supported breaking deceleration
- mountable to almost all types of wheelchairs with a wheel size of 24"
- modular construction for easy and fast transport and service
- user-friendly because of easily accessible elements such as on/off switch, adjustment of the supporting power, removal of the batteries, and of the wheels

We wish you a lot of fun and all the best with your e·motion, your **alber** team

Important safety instructions Please observe them closely!

In the interest of your safety, the e-motion may only be operated by people who:

- have been taught how to use the e-motion
- are physically and mentally capable to use the e-motion in all possible situations of employment

The instruction session is part of the delivery package. Your local dealer or one of the **alber** distributors instructs you at your convenience and no extra charge. If for some reason you still do not feel comfortable handling the e-motion, please contact your local dealer.

All the figures stated in the operating instructions provided by the manufacturer of the wheelchair, in particular ones that relate to the maximum obstruction heights, must be strictly observed. Also the operating and safety instructions for the wheelchair contained in the usage manual must be observed.

The e-motion wheels are not equipped with any independent brakes. Consequently parking brakes must be fitted to the wheelchair that can be adjusted to the e-motion wheels. In order to operate the e-motion, any drum brakes fitted to the



wheelchair must be removed. In such cases retrofitting parking brakes to the wheelchair is absolutely essential.

When transferring an occupant into or out of the wheelchair the e-motion drive must be switched off and the parking brakes applied. Under no circumstances may the push rims be used to assist in transferring the occupant.

The e-motion is designed both for indoor and outdoor use. Fundamentally, however, firm ground is a prerequisite for operating the unit.

If a mobile phone or similar device is to be used, the e-motion should provisionally be switched off on safe ground. Also travel close to strong electric interference fields should be avoided.



Never use the e-motion before you participated in the instruction session.

1

Standard Delivery Package

- 2 powered wheels
- 2 batteries
- 2 protection covers for the batteries
- alber charger plus operating instructions
- 2 blade-type electric fuses 32 V, 15 A
- holding device already mounted on the wheelchair
- Operating instructions

Essential Parts

(please fold out the attached general drawing)

- 1 Holding ring
- 2 Battery
- 3 Wheel hub
- 4 Bow-type handle
- 5 Holding device
- 6 On/Off switch
- 7 Selection button
- 8 Socket
- 9 LED display
- 10 Charge capacity button
- 11 Sensor
- 12 Protection cover
- 13 Fuse box
- 14 Fuse 32 V, 15 A
- 15 Adjustment ring

2

Technical Data e · motion

Weight of the powered wheel:	10 kg
Weight of the nickel metal hydrid battery:	2 kg
Maximum range*:	12 km
Motor power:	2 x 150 W
Voltage:	24 V
Batteries:	2 x 24 V, 2 x 3,0 Ah
Maximum weight added:	120 kg (observe the wheelchair manufacturer's specifications for this)
Pneumatic pressure:	6 bar
alber charger BCS2402:	for technical data, please consult its user's manual
Maximum obstruction height:	see wheelchair manufacturer's specifications

* The battery range varies greatly and is predominantly dependent on the quality of the driven surface on the driving conditions. At optimum conditions (even surface, fully charged batteries, motor power 50 %, temperature of 20 °C) the indicated range can be reached.

The e · motion drive system serves to assist the wheelchair driver in operating his manual wheelchair by providing him with additional power. In particular, users with limited hand

Changes in technology and design due to constant further development excepted.

and / or arm functionality can benefit from this drive system, which can be individually tailored to the user. Consequently it is also possible to pursue therapeutic goals with the e · motion.



The e · motion complies with the EU regulation for medical products 93/42/EWG and 89/366/EWG electromagnetic compatibility.

3 Wheels

3.1 Holding Device for the Wheels

To mount the e-motion to your wheelchair special holding devices are necessary, which are mounted by **alber** or any authorized **alber** dealer. These holding devices generally allow the employment of the formerly used manual wheelchair wheels as well as the use of the e-motion powered wheels.

3.2 Delivery of the Wheels and Batteries

Due to safety reasons wheels and batteries are separately delivered. Thus you can mount the wheel immediately to the wheelchair as described in the following paragraph.

We placed plastic protection covers (please see chapter 4) on the batteries' contact surfaces which you need to remove according to the instructions delivered with the batteries. Please keep these in a safe place because they are needed furthermore for the transportation and storage of the batteries (please see chapter 10).

3.3 Mounting the Wheels

Take any one of the e-motion wheels.

- In case the batteries [2] are installed in the wheel. Turn the holding ring [1] counter clockwise and pull the entire battery [2] out of the wheel. Avoid touching the contact surfaces at the battery's back side.

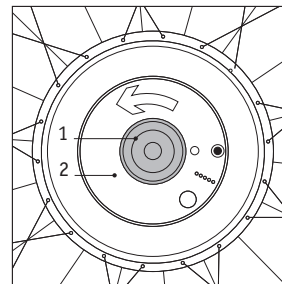

- Take the bow-type handle [4] situated in the wheel hub [3] out to 90°, which releases the locking mechanism in the axletree.

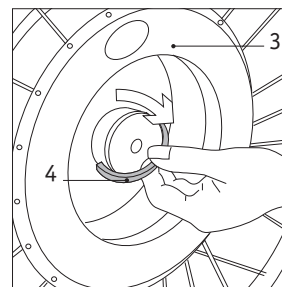

The e-motion wheel is now prepared to mount on the wheelchair

! **Attention: never hold, shift or pull the wheel by the bow-type handle [4] to avoid risk of fracture.**

- Remove your wheelchair's wheel according to the respective user's manual
- Hold the e-motion wheel at the wheel hub (as shown in the picture on the right) and insert it all the way into the holding device [5] on the wheelchair.

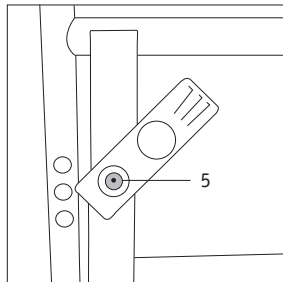
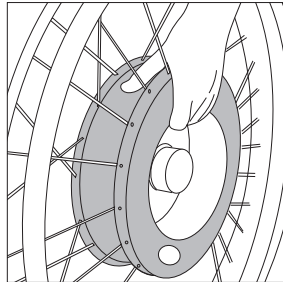

- Lock the wheel into place by putting the bow-type handle [4] back into its original position.
- Make sure the bow-type handle [4] is in its original position and level with the rest of the surface.
- The wheel sits correctly in its holding device [5] if it cannot be removed without pulling out the bow-type handle [4].
- Mount the second wheel accordingly.

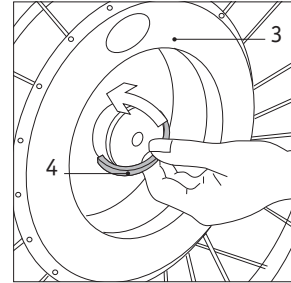

! **Instructions for removing the wheels from the wheelchair – see chapter 10**

4

Inserting the Batteries

- Lock the wheelchair's brakes to avoid any movement of the wheels.

- Make sure there is no foreign matter such as pebbles, pieces of metal etc. in the wheel hub [3].

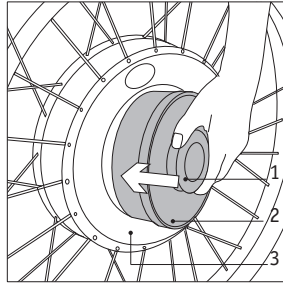

- Hold the battery [2] at its holding ring [1].
- Please remove the plastic protection covers from the battery, if you haven't done so. Avoid touching the contact surfaces (please see chapter 3.2).
- Insert the battery [2] all the way into the wheel hub [3] (you hear a clicking sound as it catches).
- If you cannot insert the battery all the way, the wheel is possibly not entirely in its holding device. Please see chapter 3.



Attention: never force the battery into the wheel hub!

- Insert the second battery [2] into the other wheel accordingly
- Release the wheelchair's brakes.

It takes such little preparation to make your wheelchair ready to use. Whether you want to activate the e·motion or not, you can still move your wheelchair as usual manually. However, you will notice that you will need a bit more physical power as before.

5

Tilt Support

(available as optional accessory)



Before you use the e-motion for the first time, you should make sure that your wheelchair is equipped with tilt support!

In the interest of your safety, they should only be removed to surmount an obstacle such as high curbs and the like. In such case you need the help of an assisting person.

Since most wheelchairs come with tilt support, the **alber** tilt support is available only as an optional accessory. It is mounted at the **alber** plant or done by your authorized local dealer or distributor, who must observe the included instructions mounting the tilt support.

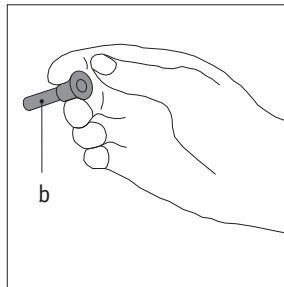
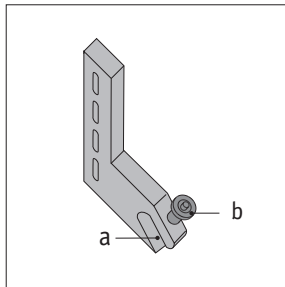

The tilt support adjusted to your wheelchair is mounted as follows:

- First remove the quick pins [b] from the holding device [d] by pressing your thumb on the center of the pin while lifting it out with your middle and index finger (see detail in the drawing)
- Insert the tilt support [c] into the holding device [a]. (The tilt support for the left side is marked with an "L", for the right with an "R".)

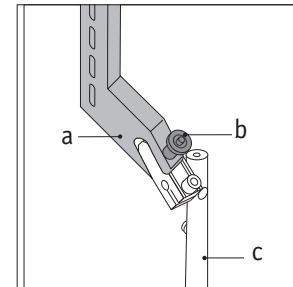
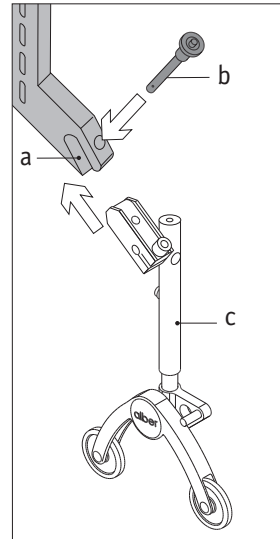

- Secure the tilt support in the holding device [a] with the quick pins [b]. Press the locking mechanism in the center of the locking pin and push the pin entirely into the holding device.
- Check whether the quick pins [b] securely rest in the holding device [a]. You are not supposed to be able to remove them without pressing the locking mechanism in their center.
- To remove the tilt support, work your way back step by step.

! Driving the e-motion without attached tilt support is not safe, thus not admissible.

The CE conformity for the e-motion is only valid in combination with the tilt support.

In addition, the following points have to be taken in consideration:

- Assembly and repairs as well as any other work done on the e-motion must be carried out by Ulrich Alber GmbH or any other personnel authorized by **alber**.
- The lower part of the tilt support must be attached high enough so that their wheels can rotate freely when the wheelchair is on a horizontal level.
- The user must pay particular attention to the following:
 - a) The tilt support must be unobstructed.

b) Please be extra careful when driving over obstacles higher than 40 mm and narrower than the sidewalk's curb.

c) The critical height of obstacles must be tested individually for each wheelchair equipped with the e-motion and his/her driver.

d) The point at which a certain wheelchair equipped with the e-motion tilts backwards at its back axle must also be tested by its user. The critical limit is reached at the point where the tilted wheelchair falls backwards.

! Important safety note

Due to blows or impact caused, for example, by unintentionally setting down on too high kerbs, particularly the toothed sections [d] in the anti-tipping supports may be subject to above average loading. Consequently the condition of the teeth (see illustration for the precise position) should be checked at least once a week.

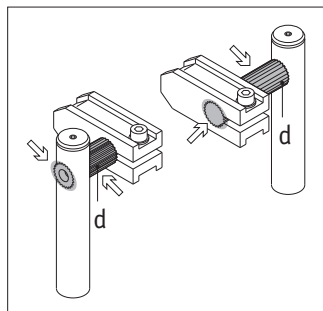

Condition of toothed sections

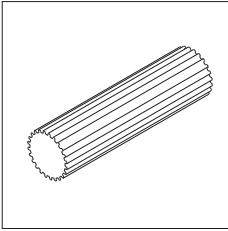

Undamaged teeth:
anti-tipping supports can continue to be used.

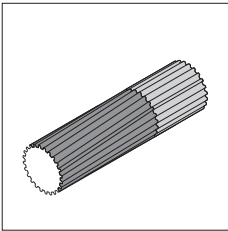

Teeth twisted:
replace anti-tipping supports immediately!

Swivel the anti-tipping supports as shown:

- Toothed section [d] sits tight within the holder [e] and the adjusting tube [f] and cannot be twisted: anti-tipping supports can continue to be used.
- Toothed section [d] can be twisted within the holder [e] or the adjusting tube [f]: teeth are twisted – replace anti-tipping supports immediately!

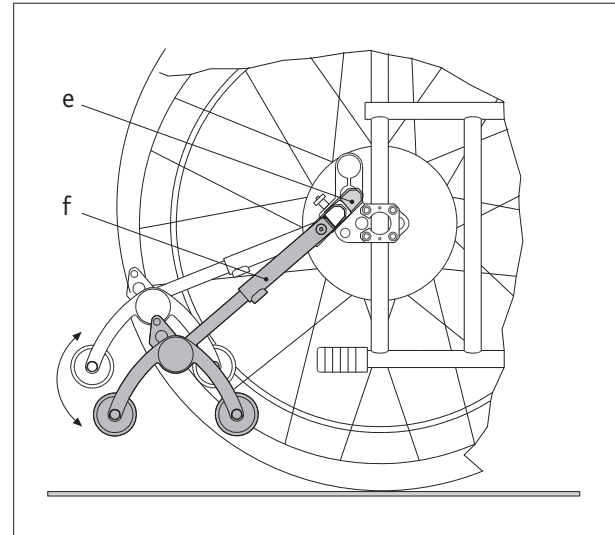

6 Operation

All of e·motion's operation and service elements are housed in its battery [2] and the wheel hub [3].

6.1 Turning on

- Depress the on/off switch [6] for a moment; the e·motion is switched on. You hear a beep when the e·motion is on.
- Depending on the pre-selected drive mode (see chapter 7), one or two signal tones follow.

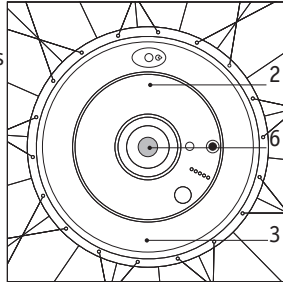

7 Levels of Power

e·motion is equipped with two levels of power, which are indicated by an acoustic signal. (Please see chart 7.1).

- Turn the e·motion on.
- To activate the desired level, please press briefly the selection button [7]. The program automatically jumps one step per keystroke.

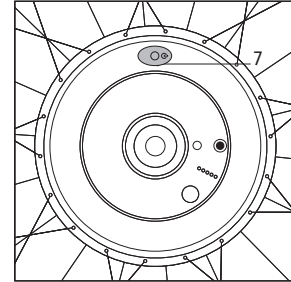

Once you select a level, the e·motion remembers it even after turning it off, i.e. restarting the e·motion you are on the same level as you were before turning it off.

6.2 Turning off

Briefly press the on/off switch [6]. You just hear a beep when the e·motion is turned off.

7.1 Power Survey

Signal	Motor performance	Recommended being of use area	Energy consumption
1 signal tone	50 %	Mainly used indoors	low, batteries saved, longest range
2 signal tones	80 %	Use in outside areas and for inclines, maximum braking available for declines	increased consumption



The level of power support can be selected for each wheel and if necessary pre-selected also.

7.2

Sensitivity control

Your e·motion is equipped with two levels of power support (see chart 7.1). Each level can be adjusted individually to provide different power levels for the right or the left arm respectively. This means that you need a higher or lower level of power at the push rims to operate the e·motion.

Your therapist or your local dealer can adjust the level of power you need at the adjustment ring. Please do not make your own adjustments at the adjustment ring [15]. If the wheels are adjusted differently, please mark them with stickers "L" (left) and "R" (right) in order to put the wheels back on the appropriate sides after e.g. transporting the wheelchair.



The setting of the sensitivity and the motor parameter may be done exclusively by a specialized authorized dealer or your therapist.

8

Automatic Switch Off

To save energy your e·motion is equipped with an automatic switch off.

- The automatic switch-off is activated, when the drive is switched on but not used for a period of 30 minutes. An increase of the automatic switch-off time to 120 minutes is possible and can be adjusted by your specialist dealer or therapist.

- Due to the automatic switch off a slight braking action is activated for the period of 2 minutes. You can still move the wheel, but it will take more physical power.

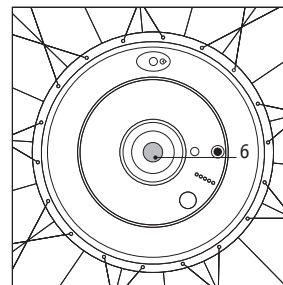

- If you want to cancel the automatic switch off during these 2 minutes, simply press the on/off switch [6].
- After the two-minute slight braking action the e·motion turns itself off completely.
- The automatic slight braking action is also activated for 2 minutes, if there is an abnormal occurrence before or during the operation of the e·motion (please also see chapter 11).

9

Batteries

9.1

Functions and Display

All the e-motion's displays necessary for operation are located on the battery [2].

You receive information concerning the charge of the batteries by pressing the button [10]. The battery's charge is displayed on the LED display [9]. You read the LED display as follows:

- 2 green active LEDs:
60 -100 % charge capacity
- 2 orange active LEDs:
20 -60 % charge capacity
- Red LED active:
20 % charge capacity
- 1 red LED flashes:
< 10 % charge capacity

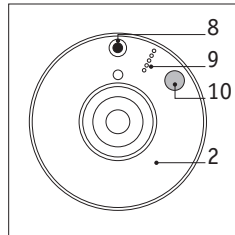

! **Red light on:**
At this point, stop your e-motion immediately and recharge the batteries!

- When 10 % or less charge capacity is reached, 4 signals sound every minute.

9.2

Charging the Batteries

- Please exclusively use the **alber** charger BCS2402A to charge

your batteries. The **alber** charger is part of the standard delivery package.

- Push the battery charger plug into the socket [8] on each of the two rechargeable batteries [2].
A connection is made when the marking (red ring) on the charging plug is covered completely by the systemunit and no longer visible.



- For instructions concerning the charging capacity and the times it takes to charge the batteries, please consult the charger's user's manual.

! **Both batteries are fully charged, when the green battery charger LEDs are active.**

Depending on the selected level of power of the respective wheels, the batteries may run low at different times. Please also see chapter 7.1. Due to security reasons you should always turn off both batteries (even if one of them is not low yet) and recharge both at the same time. Temperature must be above 10 °C when charging the batteries.

9.3

Storage and Transportation

Except for transportation, you generally may leave the batteries in the e·motion wheel at all times.

9.4

Protection of the Socket.

Whenever you do not use the socket [8], cover it with the plastic protection cover [12] to avoid dampness from entering into the socket. Please see also chapter 3.2 and 4.

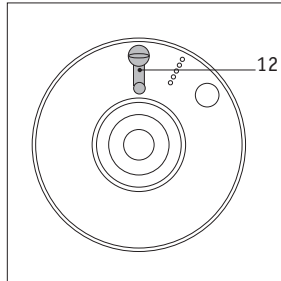

9.5

Changing the Fuses

- Carefully pull out the fuse box [13] located on the side of the battery until it locks.
- Take out the plugged in blade-type fuse [14].
- Put in a new blade-type fuse [14].
- Push the fuse box [13] back into the battery [2].
- See whether the e·motion works by turning it on and driving a short distance.

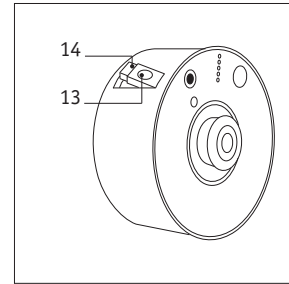

If you need to change the fuse once again shortly after, there might be a malfunction in the system. In such case, please contact your dealer.

9.6 Recycling

At the end of the batteries' service life, **alber** or their dealers take them back to recycle them appropriately.

10 Removing the wheels, transport

Generally the e-motion wheels remain on the wheelchair at all times. Only in case of transportation when the wheelchair has to be folded, you need to take the wheels off. Please follow these instructions:

- The following only applies to wheels which have different selected power levels:
Indicate the right and left wheel as well as their respective batteries with the stickers „R“ (right) and „L“ (left).
It is indispensable that you mount the respective wheels on the correct side to have the individually selected power level where you need it.

- Turn the holding ring [1]
counter clockwise pulling
the battery (2) out of the
wheels. Do the same at the
other wheel. Please avoid
touching the batteries'
contact surfaces.

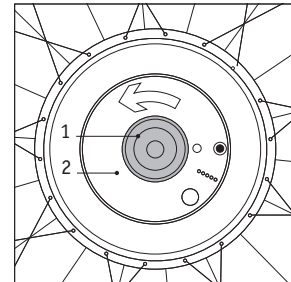

Place the plastic protection covers on the batteries (please see chapter 9.4).

- Take the bow-type handle [4] situated in the wheel hub [3] out to 90°, which releases the locking mechanism within the axletree.

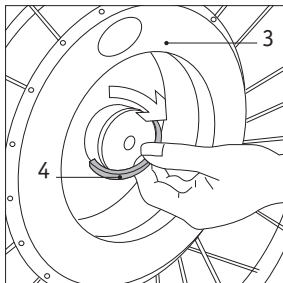

- Take the wheel off the wheelchair. Attention never hold, pull or shift the wheel by the bow-type handle [4] to avoid risk of fracture.

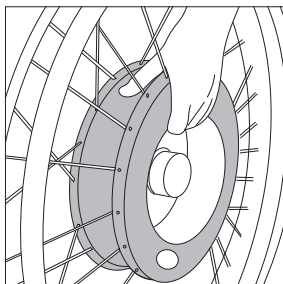

- Take off the tilt support.



In order to avoid damaging the e-motion during transport, please observe the following instructions:

- **Place the plastic protective covers provided on the battery contact terminals.**
- **Never hold, pull or displace the wheel by its bow-type handle [4].**
- **When removing the wheels do not hold them by the push rims.**
- **Do not carry or transport the wheels by the push rims.**
- **Avoid overturning the wheels. Place them down carefully and make sure that the push rims do not rest on each other.**
- **To avoid damage during transportation, make sure that the two wheels do not touch each other.**

11 Signal Codes

Your e-motion alerts you to various conditions of operation by acoustic signals:

Signal form	Meaning	Fault appearance
•	On depressing key [7]: support mode 1 is activated	
••	On depressing key [7]: support mode 2 is activated	
••	If switched on, but not in used for 30 (or 120) minutes, then switch-off is automatic	
••••	During the journey: battery capacity less than 10 %	4
—	During the journey: battery must be re-charged, immediately (constant signal tone)!	
— — — —	You hear 4 beeps, the charger is still connected, driving is not yet possible	1
— •	as you drive or when you turn it on, excess temperature of the motor	1
— • •	as you drive or when you turn it on, error of sensor	1
— • • •	as you drive or when you turn it on, excess-voltage	1
— • • • •	as you drive or when you turn it on, excess current	1
— • • • • •	as you drive or when you turn it on, malfunction	2
— — — — —	as you drive or when you turn it on, error of processor.	3

- 1 The e-motion wheel in question is slightly braked for 2 minutes; afterwards it is turned off completely. If this happens more frequently, please contact your dealer.
- 2 You cannot turn on the e-motion wheel in question. Please contact your dealer.
- 3 Taking batteries in and out. If this error continues to come up, the motor needs to be exchanged.
- 4 After appearance of this warning signal, the power to the drive wheels is reduced.

12

Instructions for driving the e·motion

12.1

General instructions

e·motion's powered engine supports the power the wheelchair driver needs to move his or her wheelchair. The sensors (11) on the gripping rings convert that power into a brief turning motion of the motor. The power's force depends on the previously selected level of power (please see chapter 7.1). It is irrelevant whether you drive the wheelchair forward or backward.

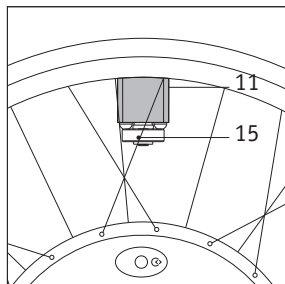

When you are driving down a slope the e·motion's engine supports the brakes.

The e·motion only indirectly influences the actual technique of driving a wheelchair, i.e. you can stick with your habits for the most part.

- When using e·motion for the first time, avoiding initially putting into operation in the second support mode.
- Start if possible with mode 1, to get to know the system and practice in a safe, flat area.

- When you are familiar with the system, then you can activate the second mode.
- Push **both wheels** evenly to make your wheelchair go straight forward.



Your specialist dealer or the alber sales representatives can adapt the e·motion to your individual needs any time.

- Going down a slope, activate the e·motion engine to be able to brake more effectively. When it is wet the push rims are getting damp so that there is a greater risk of accidents through unintentionally issued wrong driving commands.
- Turn the e·motion's engine off and lock the brakes before you get in or out of your wheelchair. Inadvertent grasping of the push rim could move the wheelchair.
- Always drive with fully charged batteries to avoid being stranded due to empty batteries. For longer trips use a second pair of batteries if necessary.
- Make sure that the air pressure in the e·motion and the wheelchair front wheels is correct, as this increases your radius of activity. The pressure in the e·motion wheel should be 6 bar. Details of the pressure in the front wheels should be taken from the usage manual for your wheelchair. If you have a flat tyre the driving characteristics of the e·motion deteriorate substantially. So only drive on in an emergency and with great care.

- The e-motion was subjected to a rain test as per ISO 7176 and functioned normally during brief showers. However, it should not be left standing for longer periods of time in the rain and journeys during rainfall as well as driving through water should be avoided.

Do not use or store the e-motion when the batteries have been removed. Ensure that the charging sockets of the batteries (see Chapter 9) are covered with the plastic cap to prevent contact with water. After coming into contact with water, dry the e-motion with a cloth.

- Despite compliance with all current EMC directives, the driving characteristics of the e-motion may be influenced by electromagnetic fields.

Under certain adverse circumstances, mobile phones and other radiating devices can result in error conditions. Furthermore, the e-motion itself can also cause interference to electromagnetic fields, which in extreme cases can lead to older alarm systems in shops being triggered or older automatic doors in public buildings to open.



Also please observe the safety instructions in the usage manual for your wheelchair, as well as the additional safety instructions in chapter 12.2 “Dangerous ground and dangerous situations”.

12.2

Dangerous ground and dangerous situations

The e-motion driver decides independently over which routes to drive, taking into account his or her driving skills and physical abilities.

Prior to starting out he/she should check the e-motion for worn or damaged tyres, as well as the state of charge of the battery. These safety checks, as well as personal driving skills are particularly important in the following dangerous situations, where the e-motion driver must decide if he/she has the ability to drive along them:

- Quay walls, landing and berthing points, paths and places close to water, unsecured bridges and dikes
- Narrow paths, sloping ground such as ramps and driveways, narrow paths beside inclines, mountain routes
- Narrow and/or sloping paths close to main arterial roads or close to chasms
- Leaf- and snow-covered or icy driving routes
- Ramps and lifting gear on vehicles



With the e-motion slopes or inclines can be driven on in accordance with the details provided by the wheelchair manufacturer. Basic prerequisites for this, however, are perfect tyre treads, the correct air pressure in the wheels, completely safe terrain and a maximum occupant weight of 120 kg.

An escorting person is essential when crossing

- Kerbs causing a gradient in excess of 15 % for the wheelchair
- Obstructions of every kind on sloping ground

as there is an increased risk of tipping over here.

When crossing main arterial roads, major crossings and railway level crossings particular care must be exercised. Never cross rails in the road or at level crossings by driving in parallel to them as the wheels could get caught in the tracks. If possible, ask someone to accompany you who can push you across the road or level crossing if you happen to come to a standstill (due to having discharged batteries, for example).

When driving up or down ramps on vehicles particular care must be exercised. During the lifting or lowering process the e-motion must be switched off and the parking brakes applied. This prevents unintentional rolling, due to an accidental drive command, for example. If necessary an escorting person should be summoned.

When it is wet the tyres have less grip on the road surface; there is a greater risk of slipping. Please adjust your driving style accordingly.

13 Care

13.1 Maintenance

- To clean use regular household cleaners diluted in water, and conventional disinfectants never petroleum ether or the like.
- Do not use a wet but merely damp cloth to wipe the surfaces.
- Make sure that the socket [8] does not get damp.

13.2 Care of batteries

- We recommend to charge the batteries before you use your e-motion for the first time because there might be a potential loss of capacity due to storage and transportation.

- To charge the batteries, always use the **alber** charger BCS2402, which is part of the delivery package
- Avoid touching the surface contacts on the back side of the batteries.
- Take the batteries out of the wheel hubs, if you do not use your e-motion for a longer period of time.
- Always use the plastic protection covers when you store or transport the batteries.
- Do not store the batteries in place where they are exposed to high temperatures or direct sun light.

13.3

Corrosion information

All e-motion parts are made of aluminium or stainless steel. The material transition points were also subjected to surface treatment. Consequently there is no increased risk of corrosion. Despite that it is recommended that wet or moist e-motion wheels be dried off after use with a cloth as a precautionary measure.

14 Service and Repair

Your e-motion is a device low in maintenance, which will give you no problems if you take good care of it.

However, in the interest of your safety, there should be a maintenance check regularly every two years, even if your e-motion outwardly shows no damage or malfunction whatsoever. Please contact your dealer or any **alber** representative concerning maintenance.



When the batteries are transported, the plastic protection covers must be in place.

15 Recycling

Your e-motion and its batteries are products with a long service life. At its end, **alber** or the alber representatives take the device or the batteries back to recycle them appropriately. So please dispose of the batteries properly and do not include them with your household rubbish.

16 Warranty and Liability

16.1 Warranty

The time of warranty for the e-motion amounts to 24 months (6 months for the batteries) from the date of purchase, and covers faulty material and processing defects.

The warranty does not include:

- natural wear and tear
- damage caused by improper use
- forced damage
- unauthorized changes made on the device and/or its accessories

16.2 Liability

Neither Ulrich Alber GmbH nor its agents or authorized dealers and sales representatives will be liable for the safety, reliability or performance of the e-motion or for any claims for personal injury or property damage which may arise from the following:

- The e-motion was driven without tilt support.
- The e-motion was handled and used inappropriately.
- The e-motion was used other than in accordance with all instructions and precautions included in the operator's instruction manual and on the product labeling.
- The e-motion was not checked every two years by an authorized dealer or Ulrich Alber GmbH.
- Assembly, repairs and other work was done by unauthorized personnel.
- Parts or accessories other than those recommended by the manufacturer of the e-motion were used.
- Parts of the e-motion were changed or removed entirely.

17 Index

A		H	
Adjustment ring	4, 14	Holding device	4, 6, 7, 9, 10
B		Holding ring	4
Battery	4, 5, 6, 8, 15, 16, 22	L	
Bow-type handle	4	LED display	4, 15
Brakes	3, 8	Levels of power	12, 13, 14
C		Liability	24
Capacity	15	Lock	7
Care	22	M	
Charge of batteries	15	Maintenance	22
Charger	15	Motor power	5, 13
Changing the fuses	16	O	
Corrosion information	23	Occurrence	14
D		On/off switch	4, 12
Delivery package	4	Operation	12
Driving level	12	P	
F		Press button	4
Fuse	4	Protection cover	4, 18
Fuse box	4		

Q

Quick pin 9, 10

R

Recycling 17, 24

Range 5

Repair 23

S

Selection button 4

Sensitivity 14

Sensor 4, 20

Service 23

Signal codes 19

Socket 4, 15, 16

Stopping motion 14

Storage 16

T

Technical data 5

Tilt support 9

Transportation 16, 17

Turning on 12

Turning off 12

W

Warranty 24

Weight 5

Wheel hub 4, 7

Wheels 6

Ihre alber-Vertretung / Your alber representative / Votre représentation alber /
Vostra rappresentanza alber / Su representación alber / Din alber representant /
Din alber-agenturene / Uw distributeur alber / Deres alber-repræsentation



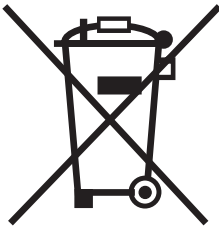

D Dieses Produkt ist von einem umweltbewussten Hersteller geliefert worden, der gemäß der Verordnung 2002/96/CE zur Entsorgung von Elektro- bzw. Elektronikschrott (WEEE) arbeitet.

Dieses Produkt kann Stoffe enthalten, die sich für die Umwelt als schädlich erweisen könnten, falls sie an Orten (Mülldeponien) entsorgt werden, die nach der Gesetzgebung dafür nicht geeignet sind.

Das Symbol der „durchgestrichenen Mülltonne“ befindet sich auf diesem Produkt, um Sie an die Verpflichtung zum Recycling zu erinnern.

Bitte verhalten Sie sich umweltbewusst und führen Sie dieses Produkt am Ende seiner Nutzungsdauer Ihrer Recyclingeinrichtung zu.

GB This product has been supplied from an environmentally aware manufacturer that complies with the Waste Electrical and Electronic Equipment (WEEE) Directive 2002/96/CE.

This product may contain substances that could be harmful to the environment if disposed of in places (landfills) that are not appropriate according to legislation.

The 'crossed out wheeled bin' symbol is placed on this product to encourage you to recycle wherever possible.

Please be environmentally responsible and recycle this product through your recycling facility at its end of life.

S Den här produkten har levererats från en miljömedveten leverantör och som uppfyller normerna i Waste Electrical and Electronic Equipment (WEEE) Directive 2002/96/CE.

Den här produkten kan innehålla ämnen som kan skada miljön om den inte återvinns enligt Svensk lagstiftning.

Symbolen, den "överkryssade soptunnan" är placerad på denna produkt för att uppmana till återvinning då det är möjligt.

Vänligen tag miljöansvar och återvinn denna produkt genom din lokala återvinningsstation.

F Ce produit vous a été fourni par alber, un fabricant qui respecte l'environnement. Il est conforme à la directive 2002/96/CE Rebut des équipements électriques et électroniques(WEEE).

Ce produit peut contenir des substances qui pourraient être nocives à l'environnement si elles sont déposées dans des endroits inappropriés (remblais par exemple) et non conformes à la législation en vigueur.

Le symbole «Époubelle barrée» est apposé sur ce produit pour vous encourager à le recycler dans les structures de collecte sélective (veuillez contacter votre Mairie).

Soyez écologiquement responsable et recyclez ce produit à la fin de sa durée de vie.

NL Dit product is geleverd door een milieubewuste fabrikant die volledig voldoet aan de richtlijnen van de Electrical and Electronic Equipment (WEEE) Directive 2002/96/CE.

Dit product kan stoffen bevatten die schadelijk zijn voor het milieu wanneer deze niet volgens de richtlijnen worden afgevoerd.

Het container symbool geeft aan dat u wordt verzocht het product te recyclen wanneer mogelijk.

Neem alstublieft uw verantwoordelijkheden en recycle dit product via een erkend recyclingbedrijf aan het eind van het gebruiksleven.

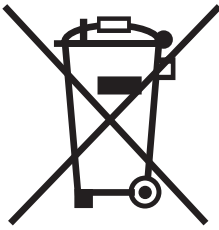

I Questo prodotto è stato fornito da un fabbricante in conformità alla direttiva "gestione dei rifiuti di apparecchiature elettriche ed elettroniche (RAEE)" 2002/96/CE.

Questo prodotto può contenere delle sostanze che potrebbero essere dannose per l'ambiente se eliminato in luoghi non appropriati (punti di raccolta) conformemente alla legislazione in vigore.

Il simbolo " contenitore di spazzatura barrato" collocato su questo prodotto vi incoraggia a riciclarlo consegnandolo nei punti di raccolta appropriati.

Comportatevi in maniera responsabile verso l'ambiente e riciclate questo prodotto alla fine della sua durata di vita.

E Este producto ha sido fabricado por una empresa que cumple con la Directiva Europea 2002/96/EC relativa a los aparatos eléctricos y electrónicos y la gestión de sus residuos.

Este producto puede contener sustancias perjudiciales para el medio ambiente si su manipulación es inapropiada o no es conforme a la legislación en vigor.

El contenedor tachado es un símbolo que indica la recogida selectiva de aparatos eléctricos o electrónicos para incentivar siempre que sea posible el reciclaje.

Por favor, actúe de forma responsable con el medio ambiente y recicle este producto al final de su vida útil.

DK Dette produkt er fremstillet af en miljøbevidst producent, som opfylder normerne i Waste Electrical og Electronic Equipment (WEEE) direktiv 2002/96/CE.

Dette produkt kan indeholde stoffer, der kan være skadelige for miljøet, hvis de ikke bortskaffes i henhold til gældende lovgivning.

Symbolet, den "overkrydsede skraldespand", er placeret på dette produkt for at opfordre til genbrug, hvor det er muligt.

Tag venligst miljøansvar og genbrug dette produkt gennem din lokale genbrugsstation, når dets levetid er omme.

N Dette produktet er levert fra en miljøbevist leverandør som oppfyller normene i Waste Electrical and Electronic Equipment (WEEE) Directive 2002 / 96 / CE.

Dette produktet kan inneholde emner som kan skade miljøet om det ikke resirkuleres etter norske regler.

Symbolet, den "overkryssede søppelkasse" er plassert på dette produktet for å oppfordre til resirkulering da dette er mulig.

Vær vennlig å ta miljøansvar, resirkuler dette produktet gjennom din gjenvinningsstasjon.

FIN Tämän tuotteen on toimittanut ympäristötietoinen yritys, joka noudattaa Euroopan yhteisön asettamaa direktiiviä 2002/96/EE sähkö- ja elektroniikkalaiteromusta (WEEE).

Tuote voi sisältää aineita jotka ovat ympäristölle haitallisia, jos ne joutuvat ympäristöön (jättemaa), johon ne eivät lain mukaan kuulu.

Tuotteeseen merkitty symboli "ei jäteastiaan" kehottaa kierrätykseen aina kun se on mahdollista.

Ole ympäristötietoinen ja toimita tuote kierrätyspisteeseen kun se poistuu käytöstä.