



# USER FRIENDLY ANTI-TIPS OWNERS MANUAL

**DEALER/SUPPLIER:**

THIS MANUAL MUST BE GIVEN TO THE USER OF THESE ANTI-TIPS.

**USER:**

BEFORE USING THESE ANTI-TIPS, YOU MUST READ THIS MANUAL IN ITS ENTIRETY AND SAVE IT FOR FUTURE REFERENCE.

**ATTENDANTS/ASSISTANTS:**

BEFORE ASSISTING THE USER OF THESE ANTI-TIPS, YOU MUST READ THIS MANUAL IN ITS ENTIRETY AND SAVE IT FOR FUTURE REFERENCE.

# USER-FRIENDLY ANTI-TIPS

---

## **⚠ WARNING - READ THIS MANUAL**

DO NOT OPERATE THESE ANTI-TIPS WITHOUT FIRST READING AND UNDERSTANDING THIS OWNERS MANUAL. IF YOU ARE UNABLE TO UNDERSTAND THE WARNINGS, CAUTIONS AND INSTRUCTIONS, CONTACT YOUR TILITE DEALER OR TILITE CUSTOMER SUPPORT AT (800) 545-2266 BEFORE ATTEMPTING TO USE THESE ANTI-TIPS. IF YOU IGNORE THIS WARNING, YOU MAY FALL, TIP OVER OR LOSE CONTROL OF THE WHEELCHAIR AND SERIOUSLY INJURE YOURSELF OR OTHERS OR DAMAGE THE WHEELCHAIR.

## **⚠ WARNING - WHEELCHAIR SELECTION**

TILITE MANUFACTURES A WIDE VARIETY OF WHEELCHAIRS TO MEET THE VARIED NEEDS OF WHEELCHAIR USERS. HOWEVER, TILITE IS NOT YOUR HEALTH CARE ADVISOR, AND WE KNOW NOTHING ABOUT YOUR INDIVIDUAL CONDITION OR NEEDS. THEREFORE, THE FINAL SELECTION OF THE PARTICULAR MODEL, AND HOW IT IS ADJUSTED, AND THE TYPE OF OPTIONS AND ACCESSORIES NECESSARY REST SOLELY WITH YOU, THE WHEELCHAIR USER, AND THE HEALTH CARE PROFESSIONAL THAT IS ADVISING YOU. CHOOSING THE BEST CHAIR AND SETUP FOR YOUR SAFETY DEPENDS ON SUCH THINGS AS:

1. YOUR DISABILITY, STRENGTH, BALANCE AND COORDINATION;
2. THE TYPES OF HAZARDS YOU MUST OVERCOME IN DAILY USE (WHERE YOU LIVE AND WORK AND OTHER PLACES YOU ARE LIKELY TO USE YOUR CHAIR); AND
3. YOUR NEED FOR OPTIONS FOR YOUR SAFETY AND COMFORT (SUCH AS ANTI-TIPS, POSITIONING BELTS OR SPECIAL SEATING SYSTEMS).

IF YOU IGNORE THIS WARNING, YOU MAY ENDANGER YOUR HEALTH.

## **WARNING**

Anti-Tips are an optional accessory that can help to prevent your chair from tipping over backward. However, even the use of anti-tips will not guarantee that your chair will not tip over backward. Also, they will not prevent your chair from tipping over sideways or forward.

TiLite strongly recommends you use anti-tips with your wheelchair. This is most especially true:

1. if you are a new wheelchair rider; or
2. even if you are an experienced rider but you are switching to a new wheelchair, regardless of whether the prior chair was as lightweight as your TiLite; or
3. even if you are an experienced rider in your TiLite chair but you have made any modifications or adjustments to the configuration of your chair, such as changing the position of the front or rear wheels, changing the seat height, changing the camber or changing the seat or back angle. Any modification or change to your chair can make it easier to tip over and you should use anti-tips until you have adapted to the modified configuration; or
4. even if you are an experienced rider in your TiLite chair but your physical condition has changed.

In order to properly use your anti-tips, please follow the following rules:

1. Your anti-tips should be between 1-1/2 inches to 2 inches off the ground when they are locked in place in the “down” position.
2. If your anti-tips are set too LOW, they may “catch” on obstacles that you can expect to encounter in normal wheelchair use. If this happens, you may tip over and fall.
3. If your anti-tips are set too HIGH, their ability to prevent a backward tip-over will be limited and they may not prevent a tip-over at all.
4. ALWAYS keep your anti-tips locked in place in the “down” position unless:
  - a. You have an attendant (but your attendant must rotate the anti-tips into the “down” position whenever he or she leaves you unattended in your chair, even for a moment), or
  - b. You have to climb or descend a curb or step or overcome an obstacle. Even if this is the case, only unlock the anti-tippers if you can safely climb or descend the curb or step or overcome the obstacle and make sure the anti-tippers are locked in the “up” position.

*If you ignore these Warnings, you may fall, tip over or lose control of the wheelchair and seriously injure yourself or others or damage the wheelchair.*

**Note:** The information contained in this document is subject to change without notice. An updated version of this Owners Manual may be available at [www.tilite.com](http://www.tilite.com)

## **SAVE THIS MANUAL FOR FUTURE REFERENCE**

# USER-FRIENDLY ANTI-TIPS

## (ALL MODELS)

The configuration of the User Friendly Anti-Tips varies among TiLite chair models. The various configurations are shown in Figure 1.

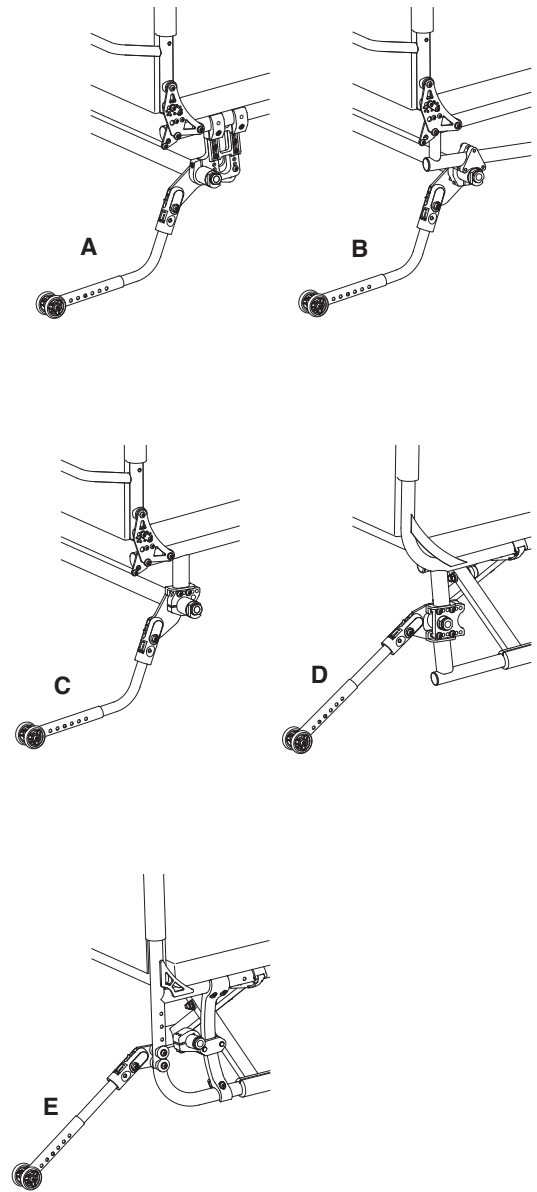
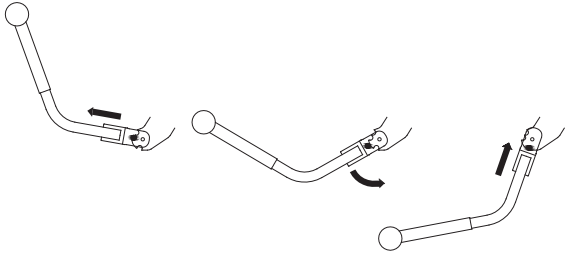

**Figure 1**  
**User Friendly Anti-Tip Configurations**

- A. ZRA and Aero Z
- B. TR, YR, TRA and YRA
- C. ZR
- D. TX
- E. 2GX, Aero X, X, SX, Evo, YG and YGS

### Engaging the Anti-Tips

To engage the user-friendly anti-tip, grip anti-tip receiver firmly and pull it rearward, away from the anti-tip mounting plate, and lower it until it re-engages in the mounting plate in the position shown in Figures 2 or 3.



**Figure 2**  
**Engaging the Anti-Tipper**  
ZRA, ZR, Aero Z, TR, YR, TRA and YRA

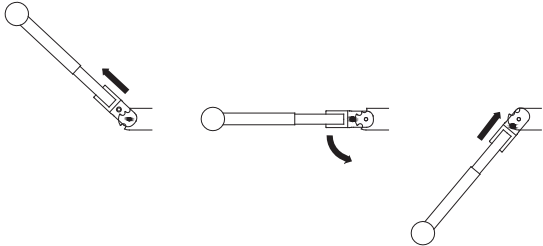

**Figure 3**  
**Engaging the Anti-Tipper**  
2GX, Aero X, TX, X, SX, Evo, YG and YGS

### Disengaging the Anti-Tip

To disengage the user-friendly anti-tip, grip the anti-tip receiver firmly and pull it downward, away from the anti-tip mounting plate, and raise it until it re-engages in the mounting plate in the position shown in Figures 4 or 5.

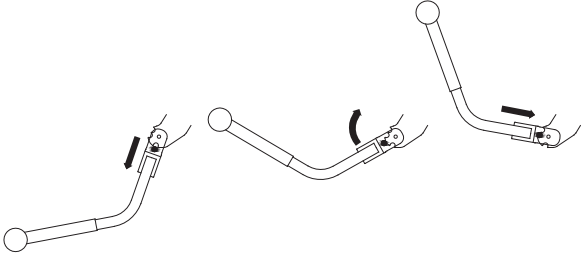

**Figure 4**  
**Disengaging the Anti-Tipper**  
ZRA, ZR, Aero Z, TR, YR, TRA and YRA

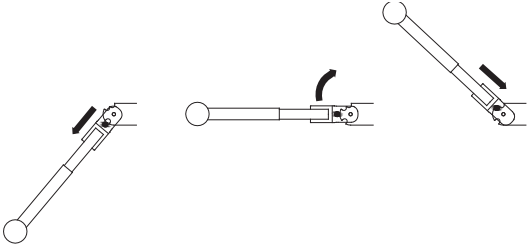

**Figure 5**  
**Disengaging the Anti-Tipper**  
2GX, Aero X, TX, X, SX, Evo, YG and YGS

# USER-FRIENDLY ANTI-TIPS

## Adjusting the Anti-Tip

To adjust the height of the user-friendly anti-tip, press the two release buttons on the telescoping lower tube, then adjust the height of the lower tube so that wheel is within 1-1/2" to 2" off the ground. See Figure 6.

## Removing the Anti-Tip

To remove the user-friendly anti-tip extension tube, press the release buttons on the anti-tip receiver and pull the upper extension tube out of the anti-tip receiver. See Figure 6.

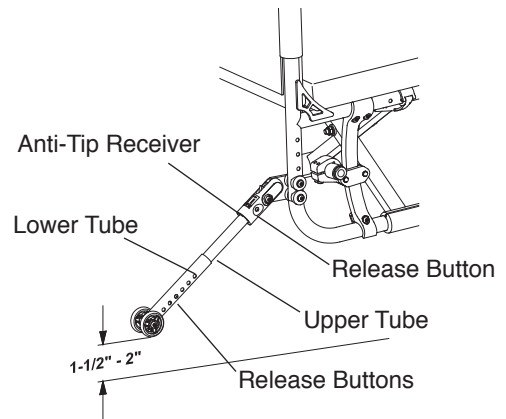
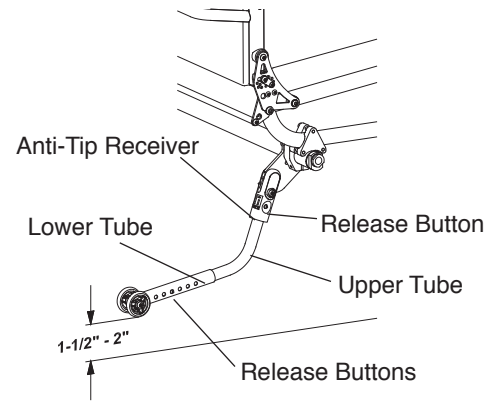

**Figure 6**  
**Adjusting the Height/Removing the Anti-Tip**

## Mounting the User-Friendly Anti-Tip

(ZRA and Aero Z)

### ⚠ WARNING

Mounting the user-friendly anti-tip receiver must be performed by an authorized TiLite dealer or qualified technician. *If you ignore this warning, you may fall, tip over or lose control of the wheelchair and seriously injure yourself or others or damage the wheelchair.*

### ⚠ WARNING

Do not disassemble the anti-tip mounting assembly (see Figure 7). *If you ignore this warning, you may fall, tip over or lose control of the wheelchair and seriously injure yourself or others or damage the wheelchair.*

Tools Needed:

- 5/32" Allen Wrench
- 7/16" Open End Wrench

1. Remove the rear wheels and place the frame on a level surface.
2. Loosen the Allen Screws that secure the camber tube to the camber tube mounts and slide the camber tube out of one of the two camber tube mounts. See Figure 7.
3. Without disassembling the anti-tip mounting plates from the anti-tip receivers, slide the camber tube through the large hole in both anti-tip mounting plates.
4. **⚠ WARNING:** Make sure that the TiLite logo is visible on the rearward side of the user-friendly anti-tip receivers as shown in Figure 7 and that the white arrows are all aligned on the opposite (forward) side of the anti-tip components as shown in Figure 7. *If you ignore this warning, you may fall, tip over or lose control of the wheelchair and seriously injure yourself or others or damage the wheelchair.*
5. Reinstall the camber tube. See "Standard Camber Tube—Replacing the Camber Tube (ZRA and Aero Z)" on pages 55-56 of the TiLite Rigid Owners Manual.
6. With the wheelchair standing upright on a level surface, engage the anti-tip as described under "Engaging the Anti-Tip" above.
7. Align the holes and slots on the forward end of the anti-tip mounting plate with the holes on camber tube mount and insert the two Allen Screws through the camber tube mount and anti-tip mounting plate.
8. Securely tighten the Allen Screws and Nylock Nuts that secure the anti-tip mounting plate to the camber tube mount.
9. Adjust the height of the anti-tip as described under "Adjusting the Anti-Tip" above.

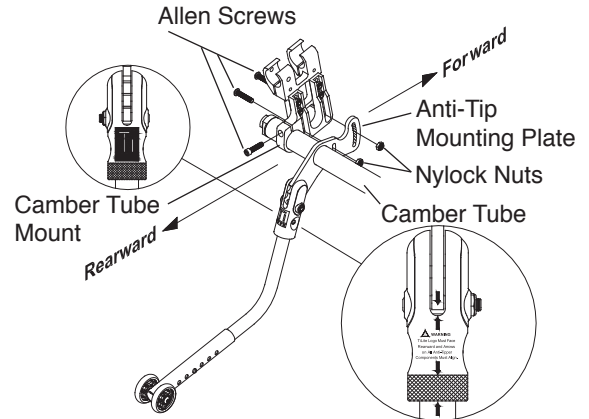

**Figure 7**  
Mounting the Anti-Tip to the ZRA and Aero Z

# USER-FRIENDLY ANTI-TIPS

10. **⚠ WARNING:** Before sitting in the chair, make sure that the anti-tips are operating properly. To do this, place the chair on a level surface and engage the anti-tips. Tip the chair backward until the weight of the chair is supported by the anti-tips and rear wheels. Apply sufficient pressure to ensure that the anti-tips are operating properly. *If you ignore this warning, you may fall, tip over or lose control of the wheelchair and seriously injure yourself or others or damage the wheelchair.*

## Mounting the User-Friendly Anti-Tip

(ZR)

### **⚠ WARNING**

Mounting the user-friendly anti-tip receiver must be performed by an authorized TiLite dealer or qualified technician. *If you ignore this warning, you may fall, tip over or lose control of the wheelchair and seriously injure yourself or others or damage the wheelchair.*

### **⚠ WARNING**

Do not disassemble the anti-tip mounting assembly (see Figure 8). *If you ignore this warning, you may fall, tip over or lose control of the wheelchair and seriously injure yourself or others or damage the wheelchair.*

Tools Needed:

- 5/32" Allen Wrench

1. Remove the rear wheels and place the frame on a level surface.
2. Loosen the allen screws that secure the camber tube within the camber clamp. See Figure 8.
3. Without disassembling the anti-tip mounting plate from the anti-tip receiver, slide the camber tube through the large hole in both anti-tip mounting plates.
4. **⚠ WARNING:** Make sure that the TiLite logo is visible on the rearward side of the user-friendly anti-tip receivers as shown in Figure 8 and that the white arrows are all aligned on the opposite (forward) side of the anti-tip components as shown in Figure 8. *If you ignore this warning, you may fall, tip over or lose control of the wheelchair and seriously injure yourself or others or damage the wheelchair.*
5. Reinstall the camber tube. See “Standard Camber Tube—Replacing the Camber Tube (ZR)” on pages 56-57 of the TiLite Rigid Owners Manual.
6. With the wheelchair standing upright on a level surface, engage the anti-tip as described under “Engaging the Anti-Tip” above.

7. Align the holes on the forward end of the anti-tip mounting plate with the threaded holes on CG bracket. Select two threaded holes on the CG bracket that are not already in use to secure the camber clamp to the CG bracket. Insert the two Allen Screws through the lock washers and anti-tip mounting plate and into the two unused threaded holes in the CG bracket.

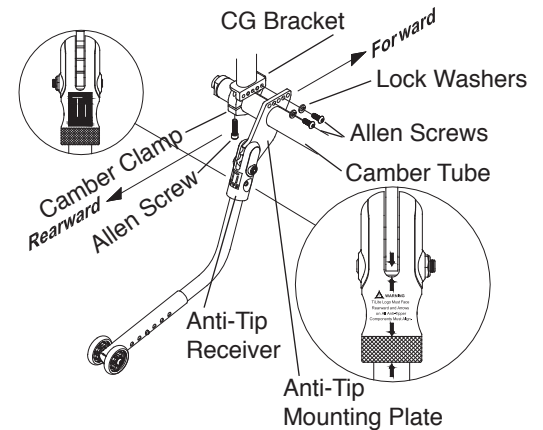

**Figure 8**  
**Mounting the Anti-Tip to the ZR**



8. Securely tighten the Allen Screws that secure the anti-tip mounting plate to the CG bracket.
9. Adjust the height of the anti-tip as described under “Adjusting the Anti-Tip” above.
10. **⚠️ WARNING:** Before sitting in the chair, make sure that the anti-tips are operating properly. To do this, place the chair on a level surface and engage the anti-tips. Tip the chair backward until the weight of the chair is supported by the anti-tips and rear wheels. Apply sufficient pressure to ensure that the anti-tips are operating properly. *If you ignore this warning, you may fall, tip over or lose control of the wheelchair and seriously injure yourself or others or damage the wheelchair*

## Mounting the User-Friendly Anti-Tip

(TR and YR)

### ⚠️ WARNING

Mounting the user-friendly anti-tip receiver must be performed by an authorized TiLite dealer or qualified technician. *If you ignore this warning, you may fall, tip over or lose control of the wheelchair and seriously injure yourself or others or damage the wheelchair.*

### ⚠️ WARNING

Do not disassemble the anti-tip mounting assembly (see Figure 9). *If you ignore this warning, you may fall, tip over or lose control of the wheelchair and seriously injure yourself or others or damage the wheelchair.*

**NOTE:** Unless you ordered user-friendly anti-tips when you originally ordered your TiLite TR or YR, you will need to order replacement Allen Screws, camber tube mounts and camber tube clamps when ordering user-friendly anti-tips.

Tools Needed:

- 3/16” Allen Wrench

1. Remove the rear wheels and place the frame on a level surface.
2. Remove the Allen Screws that secure the camber tube clamps to the camber mounts. See Figure 9.
3. Loosen the Allen Screws that secure the camber tube within the camber tube clamps and slide the camber tube clamps off the camber tube.
4. Without disassembling the anti-tip mounting plate from the anti-tip receiver, slide the camber tube through the large hole in both anti-tip mounting plates.
5. Reinstall the camber tube clamps onto the camber tube but do not yet tighten the clamps.
6. Reattach the camber tube clamps and the anti-tip mounting plates to the camber mounts using the Allen Screws as shown in Figure 9.

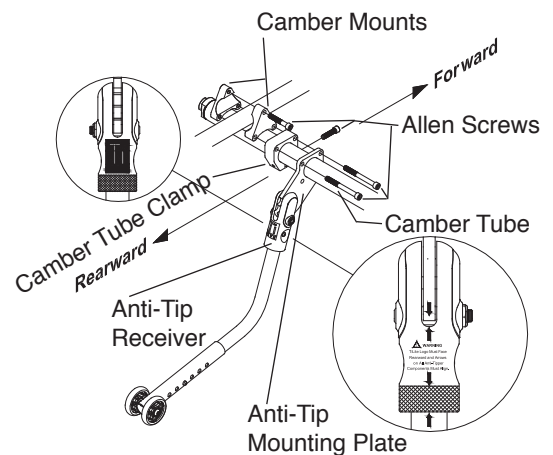

**Figure 9**  
Mounting the Anti-Tip to the TR and YR

# USER-FRIENDLY ANTI-TIPS

7. **⚠️ WARNING:** Make sure that the TiLite logo is visible on the rearward side of the user-friendly anti-tip receivers as shown in Figure 9 and that the white arrows are all aligned on the opposite (forward) side of the anti-tip components as shown in Figure 9. *If you ignore this warning, you may fall, tip over or lose control of the wheelchair and seriously injure yourself or others or damage the wheelchair.*
8. Securely tighten all Allen Screws.
9. Reinstall the rear wheels.
10. With the wheelchair standing upright on a level surface, engage the anti-tip as described under “Engaging the Anti-tip” above.
11. Adjust the height of the anti-tip as described under “Adjusting the Anti-Tip” above.
12. **⚠️ WARNING:** Before sitting in the chair, make sure that the anti-tips are operating properly. To do this, place the chair on a level surface and engage the anti-tips. Tip the chair backward until the weight of the chair is supported by the anti-tips and rear wheels. Apply sufficient pressure to ensure that the anti-tips are operating properly. *If you ignore this warning, you may fall, tip over or lose control of the wheelchair and seriously injure yourself or others or damage the wheelchair.*
13. Check the toe-in/toe-out and adjust as needed.

## Mounting the User-Friendly Anti-Tip

(TRA and YRA)

**⚠️ WARNING:**  
Mounting the user-friendly anti-tip receiver must be performed by an authorized TiLite dealer or qualified technician. *If you ignore this warning, you may fall, tip over or lose control of the wheelchair and seriously injure yourself or others or damage the wheelchair.*

**⚠️ WARNING:**  
Do not disassemble the anti-tip mounting assembly (see Figure 10). *If you ignore this warning, you may fall, tip over or lose control of the wheelchair and seriously injure yourself or others or damage the wheelchair.*

**NOTE:** Unless you ordered user-friendly anti-tip when you originally ordered your TiLite TRA or YRA, you will need to order replacement Allen Screws when ordering user-friendly anti-tips.

Tools Needed:

- 3/16” Allen Wrench

1. Remove the rear wheels and place the frame on a level surface.

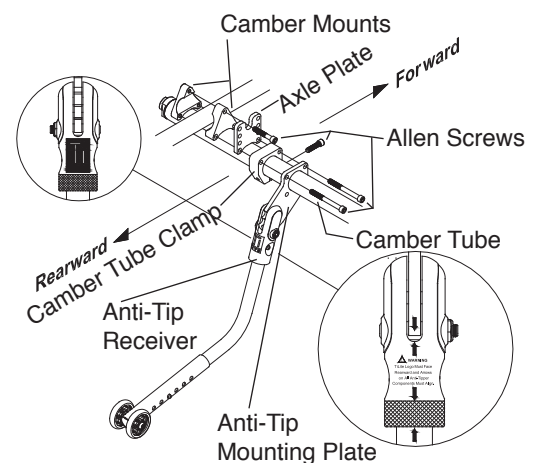

**Figure 10**  
Mounting the Anti-Tip to the TRA and YRA

2. Remove the Allen Screws that secure the camber tube clamps to the axle plates and camber mounts. See Figure 10.
3. Loosen the Allen Screws that secure the camber tube within the camber tube clamps and slide the camber tube clamps off the camber tube.
4. Without disassembling the anti-tip mounting plate from the anti-tip receiver, slide the camber tube through the large hole in both anti-tip mounting plates.
5. Reinstall the camber tube clamps onto the camber tube but do not yet tighten the clamps.
6. Reattach the camber tube clamps and the anti-tip mounting plates to the axle plates and camber mounts using the Allen Screws as shown in Figure 10.
7. **⚠️ WARNING: Make sure that the TiLite logo is visible on the rearward side of the user-friendly anti-tip receivers as shown in Figure 10 and that the white arrows are all aligned on the opposite (forward) side of the anti-tip components as shown in Figure 10. If you ignore this warning, you may fall, tip over or lose control of the wheelchair and seriously injure yourself or others or damage the wheelchair.**
8. Securely tighten all Allen Screws.
9. Reinstall the rear wheels.
10. With the wheelchair standing upright on a level surface, engage the anti-tip as described under “Engaging the Anti-Tip” above.
11. Adjust the height of the anti-tip as described under “Adjusting the Anti-Tip” above.
12. **⚠️ WARNING: Before sitting in the chair, make sure that the anti-tips are operating properly. To do this, place the chair on a level surface and engage the anti-tips. Tip the chair backward until the weight of the chair is supported by the anti-tips and rear wheels. Apply sufficient pressure to ensure that the anti-tips are operating properly. If you ignore this warning, you may fall, tip over or lose control of the wheelchair and seriously injure yourself or others or damage the wheelchair.**
13. Check the toe-in/toe-out and adjust as needed.

# USER-FRIENDLY ANTI-TIPS

## Mounting the User-Friendly Anti-Tip

(SX, X, Evo, and YG Series)

### ⚠ WARNING:

Mounting the user-friendly anti-tip receiver must be performed by an authorized TiLite dealer or qualified technician. *If you ignore this warning, you may fall, tip over or lose control of the wheelchair and seriously injure yourself or others or damage the wheelchair.*

### ⚠ WARNING:

Do not disassemble the anti-tip mounting assembly (see Figure 11). *If you ignore this warning, you may fall, tip over or lose control of the wheelchair and seriously injure yourself or others or damage the wheelchair.*

**NOTE:** Unless you ordered user-friendly anti-tips when you originally ordered your TiLite SX, X, Evo, YG or YGS you will need to order replacement Allen Screws when ordering user-friendly anti-tips.

Tools Needed:

- 5/32" Allen Wrench
- 7/16" Open End Wrench

1. Remove the rear wheels and place the frame on a level surface.
2. Remove the Nylock Nuts and Allen Screws that secure the rearward end of the axle plate to the frame. See Figure 11.
3. Without disassembling the anti-tip mounting plate from the anti-tip receiver, align the anti-tip mounting plate with the two Allen Screws and reinstall the Nylock Nuts removed in Step 2.
4. ⚠ **WARNING:** Make sure that the TiLite logo is visible on the rearward side of the user-friendly anti-tip receivers as shown in Figure 11 and that the white arrows are all aligned on the opposite (forward) side of the anti-tip components as shown in Figure 11. *If you ignore this warning, you may fall, tip over or lose control of the wheelchair and seriously injure yourself or others or damage the wheelchair.*
5. Securely tighten all Allen Screws.
6. Reinstall the rear wheels.
7. With the wheelchair standing upright on a level surface, engage the anti-tip as described under "Engaging the Anti-Tip" above.
8. Adjust the height of the anti-tip as described under "Adjusting the Anti-Tip" above.

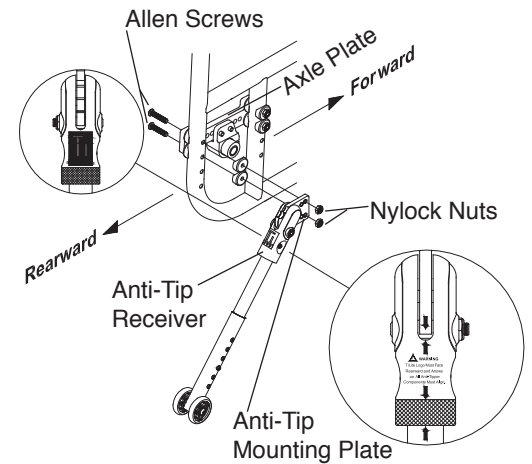

**Figure 11**  
Mounting the Anti-Tip to the SX, X, Evo and YG Series

9. **⚠️ WARNING:** Before sitting in the chair, make sure that the anti-tips are operating properly. To do this, place the chair on a level surface and engage the anti-tips. Tip the chair backward until the weight of the chair is supported by the anti-tips and rear wheels. Apply sufficient pressure to ensure that the anti-tips are operating properly. *If you ignore this warning, you may fall, tip over or lose control of the wheelchair and seriously injure yourself or others or damage the wheelchair.*
10. Check the toe-in/toe-out and adjust as needed.

## Mounting the User-Friendly Anti-Tip

(TX)

**⚠️ WARNING:** Mounting the user-friendly anti-tip receiver must be performed by an authorized TiLite dealer or qualified technician. *If you ignore this warning, you may fall, tip over or lose control of the wheelchair and seriously injure yourself or others or damage the wheelchair.*

**⚠️ WARNING:** Do not disassemble the anti-tip mounting assembly (see Figure 12). *If you ignore this warning, you may fall, tip over or lose control of the wheelchair and seriously injure yourself or others or damage the wheelchair.*

Tools Needed:  
 • 5/32" Allen Wrench

1. Remove the rear wheels and place the frame on a level surface.
2. Without disassembling the anti-tip mounting plate from the anti-tip receiver, align the anti-tip mounting plate with the CG brackets.
3. **⚠️ WARNING:** Make sure that the TiLite logo is visible on the rearward side of the user-friendly anti-tip receivers as shown in Figure 12 and that the white arrows are all aligned on the opposite (forward) side of the anti-tip components as shown in Figure 12. *If you ignore this warning, you may fall, tip over or lose control of the wheelchair and seriously injure yourself or others or damage the wheelchair.*
4. Align the holes on the forward end of the anti-tip mounting plate with the threaded holes on the upper and lower halves of the CG bracket. Select two threaded holes on the upper half and two threaded holes on the lower half of the CG bracket that are not already in use to secure the camber clamp to the CG bracket. Insert the four Allen Screws through the lock washers and anti-tip mounting plate and into the four unused threaded holes in the CG bracket.
5. Securely tighten the Allen Screws that secure the anti-tip mounting plate to the CG bracket.
6. Adjust the height of the anti-tip as described under "Adjusting the Anti-Tip" above.

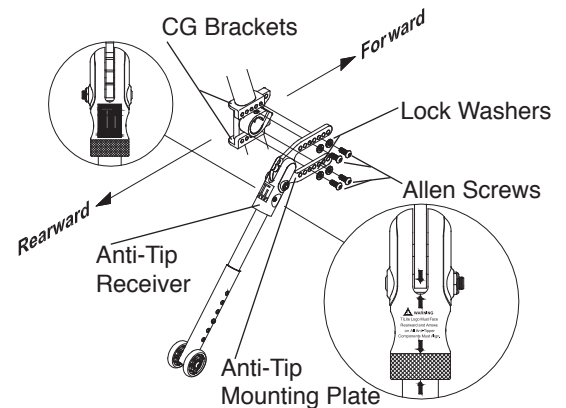

**Figure 12**  
**Mounting the Anti-Tip to the TX**

# USER-FRIENDLY ANTI-TIPS

7. **⚠️ WARNING:** Before sitting in the chair, make sure that the anti-tips are operating properly. To do this, place the chair on a level surface and engage the anti-tips. Tip the chair backward until the weight of the chair is supported by the anti-tips and rear wheels. Apply sufficient pressure to ensure that the anti-tips are operating properly. *If you ignore this warning, you may fall, tip over or lose control of the wheelchair and seriously injure yourself or others or damage the wheelchair.*

## Mounting the User-Friendly Anti-Tip

(Aero X and 2GX)

### ⚠️ WARNING:

Mounting the user-friendly anti-tip receiver must be performed by an authorized TiLite dealer or qualified technician. *If you ignore this warning, you may fall, tip over or lose control of the wheelchair and seriously injure yourself or others or damage the wheelchair.*

### ⚠️ WARNING:

Do not disassemble the anti-tip mounting assembly (see Figure 13). *If you ignore this warning, you may fall, tip over or lose control of the wheelchair and seriously injure yourself or others or damage the wheelchair.*

Tools Needed:

- 5/32" Allen Wrench
- 7/16" Open End Wrench

1. Remove the rear wheels and place the frame on a level surface.

2. Without disassembling the anti-tip mounting plate from the anti-tip receiver, align the anti-tip mounting plate with two holes in the rear of the frame and install the Allen Screws through the frame and plate as shown in Figure 13.

3. **⚠️ WARNING:** Make sure that the TiLite logo is visible on the rearward side of the user-friendly anti-tip receivers as shown in Figure 13 and that the white arrows are all aligned on the opposite (forward) side of the anti-tip components as shown in Figure 13. *If you ignore this warning, you may fall, tip over or lose control of the wheelchair and seriously injure yourself or others or damage the wheelchair.*

4. Securely tighten all Allen screws and nylock nuts.

5. Reinstall the rear wheels.

6. With the wheelchair standing upright on a level surface, engage the anti-tip as described under "Engaging the Anti-Tip" above.

7. Adjust the height of the anti-tip as described under "Adjusting the Anti-Tip" above.

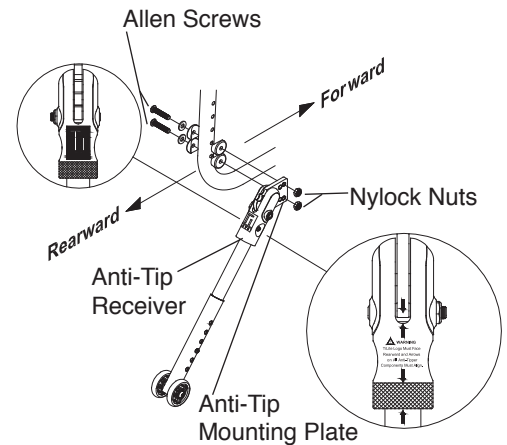

**Figure 13**  
**Mounting the Anti-Tip to the Aero X and 2GX**

8. **⚠️ WARNING:** Before sitting in the chair, make sure that the anti-tips are operating properly. To do this, place the chair on a level surface and engage the anti-tips. Tip the chair backward until the weight of the chair is supported by the anti-tips and rear wheels. Apply sufficient pressure to ensure that the anti-tips are operating properly. *If you ignore this warning, you may fall, tip over or lose control of the wheelchair and seriously injure yourself or others or damage the wheelchair.*

9. Check the toe-in/toe-out and adjust as needed.



[tilite.com](http://tilite.com)

**P** 800.545.2266 | 509.586.6117  
**F** 866.586.2413 | 509.585.8703

2701 West Court Street, Pasco, Washington 99301

A PRODUCT SUPPORTED BY:



[usersfirst.org](http://usersfirst.org)