



Evo



RIGID OWNERS MANUAL

DEALER/SUPPLIER:

THIS MANUAL MUST BE GIVEN TO THE USER OF THIS WHEELCHAIR.

USER:

BEFORE USING THIS WHEELCHAIR, YOU MUST READ THIS MANUAL IN ITS ENTIRETY AND SAVE IT FOR FUTURE REFERENCE.

ATTENDANTS/ASSISTANTS:

BEFORE ASSISTING THE USER OF THIS WHEELCHAIR, YOU MUST READ THIS MANUAL IN ITS ENTIRETY AND SAVE IT FOR FUTURE REFERENCE.

SERIAL NUMBER _____

⚠️ WARNING - READ THIS MANUAL

DO NOT OPERATE THIS WHEELCHAIR WITHOUT FIRST READING AND UNDERSTANDING THIS OWNERS MANUAL. IF YOU ARE UNABLE TO UNDERSTAND THE WARNINGS, CAUTIONS AND INSTRUCTIONS, CONTACT YOUR TILITE DEALER OR TILITE CUSTOMER SUPPORT AT (800) 545-2266 BEFORE ATTEMPTING TO USE THIS WHEELCHAIR. IF YOU IGNORE THIS WARNING, YOU MAY FALL, TIP OVER OR LOSE CONTROL OF THE WHEELCHAIR AND SERIOUSLY INJURE YOURSELF OR OTHERS OR DAMAGE THE WHEELCHAIR.

⚠️ WARNING - WHEELCHAIR SELECTION

TILITE MANUFACTURES A WIDE VARIETY OF WHEELCHAIRS TO MEET THE VARIED NEEDS OF WHEELCHAIR USERS. HOWEVER, TILITE IS NOT YOUR HEALTH CARE ADVISOR, AND WE KNOW NOTHING ABOUT YOUR INDIVIDUAL CONDITION OR NEEDS. THEREFORE, THE FINAL SELECTION OF THE PARTICULAR MODEL, AND HOW IT IS ADJUSTED, AND THE TYPE OF OPTIONS AND ACCESSORIES NECESSARY REST SOLELY WITH YOU, THE WHEELCHAIR USER, AND THE HEALTH CARE PROFESSIONAL THAT IS ADVISING YOU. CHOOSING THE BEST CHAIR AND SETUP FOR YOUR SAFETY DEPENDS ON SUCH THINGS AS:

1. YOUR DISABILITY, STRENGTH, BALANCE AND COORDINATION;
2. THE TYPES OF HAZARDS YOU MUST OVERCOME IN DAILY USE (WHERE YOU LIVE AND WORK AND OTHER PLACES YOU ARE LIKELY TO USE YOUR CHAIR); AND
3. YOUR NEED FOR OPTIONS FOR YOUR SAFETY AND COMFORT (SUCH AS ANTI-TIPPERS, POSITIONING BELTS OR SPECIAL SEATING SYSTEMS).

IF YOU IGNORE THIS WARNING, YOU MAY ENDANGER YOUR HEALTH.

⚠️ WARNING - TIE-DOWN RESTRAINTS

TILITE RECOMMENDS THAT WHEELCHAIR USERS NOT BE TRANSPORTED IN VEHICLES OF ANY KIND WHILE IN WHEELCHAIRS. AS OF THIS DATE, THE UNITED STATES DEPARTMENT OF TRANSPORTATION HAS NOT APPROVED ANY TIE-DOWN SYSTEM FOR TRANSPORTATION OF A USER WHILE IN A WHEELCHAIR IN A MOVING VEHICLE OF ANY TYPE. IT IS TILITE'S POSITION THAT USERS OF WHEELCHAIRS SHOULD BE TRANSFERRED INTO APPROPRIATE VEHICLE SEATING FOR TRANSPORTATION AND SHOULD USE THE RESTRAINTS MADE AVAILABLE BY THE AUTO INDUSTRY. TILITE CANNOT, AND DOES NOT, RECOMMEND ANY WHEELCHAIR TRANSPORTING SYSTEMS.

⚠️ WARNING - SEATING RESTRAINTS

IT IS THE OBLIGATION OF YOUR DEALER AND THE HEALTH CARE PROFESSIONALS WHO ARE ADVISING YOU TO DETERMINE IF YOU REQUIRE A SEATING RESTRAINT OR POSITIONING SYSTEM IN ORDER TO ENSURE THAT YOU CAN SAFELY OPERATE YOUR WHEELCHAIR. SERIOUS INJURY CAN OCCUR IN THE EVENT OF A FALL FROM A WHEELCHAIR.

Note: The information contained in this document is subject to change without notice. An updated version of this Owners Manual may be available at www.tilite.com

SAVE THIS MANUAL FOR FUTURE REFERENCE



Thank you for purchasing a TiLite!

Located in a 50,000 square foot facility in the southeastern corner of Washington State, TiLite is surrounded by miles of potato fields. Our biggest distraction is the occasional wind-blown tumbleweed, which gives us plenty of time to think about innovative designs and cutting-edge materials.

Your hand made TiLite wheelchair is the result of extensive research into wheeled mobility. It represents the latest in state-of-the-art design and performance. TiLite combines the finest frame and component materials with sophisticated manufacturing and quality control procedures, ensuring you many years of exceptional performance and durability.

Please take a moment to register your new TiLite with the registration card on page 10 or at <http://www.tilite.com> under the "CONTACT TiLITE" tab. This will allow us to better serve you should you have any questions regarding your TiLite.

At TiLite we took great pride in building you "The Ultimate Ride". Once again thank you for choosing TiLite.

Sincerely,

The TiLITE family.

David Lippes
Chairman & CEO

Alan Ludovici
VP of Engineering

Marty Ball
VP of Sales

Ken Winward
VP of Quality

Iain Bampton
Fabrication Supervisor

Ed Owings
Technical Director

Mark Westphal
Customer Service Director

Josh Anderson
VP of Marketing

Rick Forman
President

REGISTER YOUR TiLITE

Register online at www.tilite.com

or

Complete and mail the form on the next page

Why Should You Register:

- 1. Increase your use and enjoyment of your TiLite by receiving updates from TiLite with product information, maintenance tips and industry news.**
- 2. Enable TiLite to contact you or your health care provider if servicing is needed for your wheelchair.**
- 3. Provide your feedback to TiLite regarding your experience and needs, thereby enabling TiLite to further improve product designs.**

All information you provide to TiLite when you register will be protected by TiLite as required by applicable laws and regulations and will be used solely by TiLite.



PRODUCT REGISTRATION FORM

Register online at www.tilite.com or
Complete and mail this form

CUT ALONG LINE

Name _____

Address _____

City _____ State/Province _____

Zip/Postal Code _____ Country _____

FOLD HERE

Email _____ Day Phone No. _____

Model _____ Serial No. _____

Purchased From _____ Date of Purchase: _____

1. Method of purchase: (check all that apply)
 Medicare Insurance Medicaid Other _____

2. This product was purchased for use by: (check one)
 Self Parent Spouse Other

3. Reasons for purchasing a TiLite:
 Reputation Dealer Relative Friend Therapist/Doctor
 Advertisement: (Please Specify) _____

4. Were your expectations met in the following areas? If not, please specify.
Quality of Service: Yes No _____
Timeliness of Delivery: Yes No _____
Quality of Product: Yes No _____

FOLD HERE

5. What additional features, if any, would you like to see on this or future TiLite products?

CUT ALONG LINE



FOLD HERE



BUSINESS REPLY MAIL
FIRST-CLASS MAIL PERMIT 100 PASCO WA

POSTAGE WILL BE PAID BY ADDRESSEE

NO POSTAGE
NECESSARY
IF MAILED
IN THE
UNITED STATES

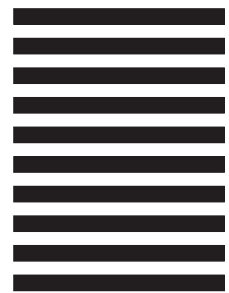

TILITE
1426 EAST THIRD AVE
KENNEWICK WA 99337-9904



FOLD HERE

TiLite Product Registration Form

Please Seal with
Tape Before Mailing

CUT ALONG LINE



Contents

CHAPTER 1: WARNINGS	1
GENERAL WARNINGS	1
A. SAFETY INSPECTIONS AND MAINTENANCE	1
B. ACCLIMATING TO YOUR NEW CHAIR	1
C. WEIGHT LIMITATION	1
D. PREVENTING ACCIDENTS AND INJURIES	1
E. CHANGING/ADJUSTING YOUR WHEELCHAIR	2
F. ENVIRONMENTAL FACTORS	2
G. STREET USE	2
H. TERRAIN	3
I. MOTOR VEHICLE SAFETY	3
J. WEIGHT TRAINING	3
K. OBTAINING ASSISTANCE	4
L. STANDING ON YOUR CHAIR	4
WARNINGS FOR SAFE USE OF YOUR WHEELCHAIR	5
A. LEARNING TO DO A “WHEELIE”	5
B. CLIMBING A CURB OR SINGLE STEP	5
C. CLIMBING A FLIGHT OF STAIRS	6
D. DESCENDING A CURB OR SINGLE STEP	6
E. DESCENDING A FLIGHT OF STAIRS	7
WARNINGS REGARDING FALLING AND TIPPING OVER	7
A. CENTER OF GRAVITY—STABILITY AND BALANCE	7
B. TRANSFERRING IN AND OUT OF YOUR WHEELCHAIR	8
C. DRESSING/UNDRESSING IN YOUR CHAIR	9
D. BENDING/LEANING/REACHING	10
E. MOVING BACKWARD	10
F. WHEELIES	10
G. OBSTACLES	11
H. CURBS/STEPS	11
I. HILLS/SLOPES/RAMPS	12
J. STAIRS	12
K. ESCALATORS	12
L. ASSISTANTS AND ATTENDANTS	13
WARNINGS REGARDING COMPONENTS AND OPTIONS	13
A. ANTI-TIPPERS	13
B. SEAT SLINGS/CUSHIONS	14
C. UPHOLSTERY FABRIC	14
D. SEATING SYSTEMS	14
E. POSITIONING OR SEAT BELTS	15
F. ARMRESTS	15
G. FOOTRESTS	15
H. REAR WHEELS	16
I. QUICK-RELEASE AXLES	16

J. PNEUMATIC TIRES	16
K. REAR WHEEL LOCKS	17
L. CASTER PIN LOCKS	17
M. PUSH HANDLES	18
N. FASTENERS	18
O. POWER DRIVE	18
P. UNAUTHORIZED PARTS AND ACCESSORIES	19
CHAPTER 2: SAFETY INSPECTION, MAINTENANCE & TROUBLE- SHOOTING	20
Introduction	20
Safety Inspections and Maintenance	20
Cleaning	22
Cleaning the Frame	22
Cleaning the Upholstery	22
Axles and Moving Parts	23
Storage	23
Troubleshooting	23
CHAPTER 3: FOOTRESTS	24
Safe Tread	24
Titanium Footrest with Flat ABS Cover (TR, YR and BB)	25
Adjusting the Height of, or Replacing, the Footrest	25
Titanium Footrest with Flat ABS Cover (ZR Series)	26
Adjusting the Height of the Footrest	26
Replacing the Footrest	26
Titanium Footrest with Flat ABS Cover (Aero Z)	27
Adjusting the Height of, or Replacing, the Footrest	27
Titanium Open Loop Footrest (TR, YR and BB)	27
Titanium Open Loop Footrest (ZR Series)	27
Titanium Open Loop Footrest (Aero Z)	28
Angle Adjustable Footrest (TR Series, YR Series, ZR Series, Aero Z, BB and Evo)	28
Adjusting the Angle of the Footrest	28
Replacing or Adjusting the Height of the Footrest	28
Angle Adjustable High Mount Footrest (TR Series, YR Series and Evo)	28
Adjusting the Angle of the Footrest	28
Replacing or Adjusting the Height	29
Angle Adjustable High Mount Footrest (ZR Series and Aero Z)	30
Adjusting the Angle of the Footrest	30
Replacing or Adjusting the Height of the Footrest	30
1-Piece Angle Adjustable Rigid (High Mount) Footrests (YG)	30
Flip-Up Footrest; Angle Adjustable Flip-Up Footrest; Depth Adjustable Flip-Up Footrest; and Depth and Angle Adjustable Flip-Up Footrest (YG Series)	31
Replacing or Adjusting the Height of the Footrest	31
Adjusting the Angle of the Footrest	31
Adjusting the Depth of the Footrest	32
High Mount Flip-Up Footrest; Angle Adjustable High Mount Flip-Up Footrest; Depth Adjustable High Mount Flip-Up Footrest; and Depth and Angle Adjustable High Mount Flip-Up Footrest (YG Series)	32
Replacing or Adjusting the Height of the Footrest	32

Adjusting the Angle or Depth of the Footrest	33
90° Hanger Flip-Up Footrests; 90° Hanger Depth Adjustable Flip-Up Footrests (YGS) .	33
Replacing, or Adjusting the Height of, the Flip-Up or Depth Adjustable Flip-Up Footrest	33
Adjusting the Depth of the Footrest	33
90° Hanger Depth and Angle Adjustable Flip-Up Footrests (YGS)	33
Replacing, or Adjusting the Height of, the Footrest	33
Adjusting the Angle of the Footrest	33
Adjusting the Depth of the Footrest	34
Swing-Away Hangers (YGS)	34
To replace the hanger on frame	34
CHAPTER 4: BACKRESTS, PUSH HANDLES AND STROLLER	
HANDLES	35
Adjustable Height & Angle Backrest (Titanium or Aluminum) (TR Series, YR Series, YG Series, ZR Series, Aero Z and Evo)	35
Folding the Backrest	35
Unfolding the Backrest	35
Adjusting the Backrest Lock Bracket	35
Adjusting if there is “Play” in the Backrest or Backrest Bracket	36
Changing the Backrest Angle	36
Adjusting the Backrest Height	37
Non-Folding Titanium Adjustable Height Backrest (BB)	37
Non-Folding Fixed Height & Angle Backrest (TR, YR and BB)	37
Stroller Handles (TRA, YRA)	38
Stroller Handles (YG Series)	38
Adjusting the Height of the Receiver	38
Bolt-On Push Handles (TR Series, YR Series, ZR Series, Aero Z and Evo)	39
Mounting Push Handles:	39
Removing Push Handles:	39
Adjustable Height Bolt-On Push Handles (TR Series, YR Series, ZR Series, Aero Z and Evo)	39
Mounting Push Handles:	39
Removing Push Handles:	40
CHAPTER 5: ARMRESTS	41
Tubular Swing Away Armrest (TR Series, YR Series, ZR Series, Aero Z and Evo)	41
Adjusting the Height of the Tubular Swing Away Armrest (ZR Series, Aero Z, TR and YR)	41
Adjusting the Height of the Tubular Swing Away Armrest (TRA, YRA and Evo)	41
Adjusting the Height of the Armrest Receiver (ZR Series, Aero Z, TR and YR)	42
Adjusting the Height of the Armrest Receiver (TRA and YRA)	42
Adjusting the Height on the Armrest Receiver (Evo)	43
Removable Desk Arm and Removable Desk Arm with Transfer Loop (TR Series, YR Series and Evo)	43
Adjusting the Armrest Height	43
Removing	43
Replacing	44
Swing Away - Flip Back Armrest (YG Series)	44
Using the Swing Away - Flip Back Armrest	44
Adjusting Armrest Height	44
Adjusting Armrest Angle	44

Locking the Armrest in Place	45
CHAPTER 6: SIDE GUARDS	46
Cloth Side Guards (TR Series, YG Series, YR Series, ZR Series, Aero Z , BB and Evo)	46
Removing/Replacing Cloth Side Guards	46
Rigid Removable and Quad Removable Side Guards (Standard and Carbon Fiber) (TR Series, YR Series, ZR Series, Aero Z, BB and Evo)	46
Using Rigid Side Guards	46
Adjusting Rigid Side Guards	46
Removing Rigid Side Guard Assembly	47
Reinstalling Rigid Side Guard Assembly	47
Fold-Down Rigid Side Guards (Standard and Carbon Fiber) (YG Series, ZR Series, Aero Z, TR, YR and Evo)	47
Using Fold-Down Side Guards	47
Removing the Fold-Down Side Guard Assembly	47
Reinstalling Fold-Down Rigid Side Guard Assembly	48
CHAPTER 7: BACK UPHOLSTERY, SEAT UPHOLSTERY AND SEAT CUSHIONS	49
Velcro Adjustable Back Upholstery (TR Series, YG Series, YR Series, ZR Series, Aero Z and Evo)	49
Adjusting the Tension	49
Replacing the Upholstery	49
Tension Adjustable by Straps Back Upholstery (TR Series, YG Series, YR Series, ZR Series, Aero Z, BB and Evo)	50
Adjusting the Tension	50
Replacing the Upholstery	50
Padded Black Nylon Back Upholstery (BB)	51
Tension Adjustable By Straps Seat Sling Upholstery (ZR Series,Aero Z, BB, TR and YR)	51
Adjusting the Tension	51
Replacing the Upholstery	52
Tension Adjustable Bolt-On Seat Sling (TR Series, YG Series, YR Series, ZR Series, Aero Z and Evo)	52
Adjusting the Tension	52
Replacing the Upholstery	53
TiLite Seat Cushion (TR Series, YG Series, YR Series, ZR Series, Aero Z, BB and Evo)	53
Replacing the Foam Insert to Your TiLite Seat Cushion	53
CHAPTER 8: CAMBER TUBES (CENTER OF GRAVITY; REAR SEAT HEIGHT)	54
Standard Camber Tube (TR Series, YR Series, ZR Series, Aero Z, BB and Evo)	54
Adjusting the Rear Seat Height (ZRA and Aero Z)	54
Adjusting the Center of Gravity (ZRA and Aero Z)	55
Replacing the Camber Tube (ZRA and Aero Z)	55
Adjusting the Center of Gravity (ZR)	56
Replacing the Camber Tube (ZR)	56
Adjusting the Center of Gravity (TR, YR and BB)	57
Replacing the Camber Tube (TR, YR and BB)	57

Adjusting the Rear Seat Height (TRA and YRA)	58
Adjusting the Center of Gravity (TRA and YRA)	58
Replacing the Camber Tube (TRA and YRA)	59
Adjusting the Rear Seat Height (Evo)	59
Adjusting the Center of Gravity (Evo)	60
Replacing the Camber Tube (Evo)	61
YG SERIES CAMBER TUBES	61
Adjusting the Rear Seat Height	61
Adjusting the Center of Gravity	62
Adjusting Toe-In/Toe-Out (TR Series, YG Series, YR Series, ZR Series, Aero Z, BB and Evo)	62
Adjustable Camber System (TR and YR)	64
Adjusting the Skewer Handle Tension	64
Changing the Camber	64
Adjusting Rear Wheel Spacing	64
Adjusting Toe-In/Toe-Out with Adjustable Camber System	65
CHAPTER 9: AXLES AND AMPUTEE ADAPTERS	67
Stainless and Titanium Quick Release Axles (TR Series, YG Series, YR Series, ZR Series, Aero Z, BB and Evo)	67
Adjusting the Quick-Release Axle	67
Quad Quick-Release Axles (TR Series, YG Series, YR Series, ZR Series, Aero Z, BB and Evo)	68
Adjusting the Quad Quick Release Handle	68
Adjusting the "Play"	69
Amputee Adapters (TR Series and YR Series)	70
CHAPTER 10: WHEEL LOCKS	71
Standard Push to Lock (TR Series, YG Series, YR Series, ZR Series, Aero Z and Evo)	71
Adjusting the Push to Lock Wheel Lock	71
Replacing the Push to Lock Wheel Lock	71
Uni-Lock (TR Series, YG Series, YR Series, ZR Series, Aero Z and Evo)	72
Adjusting the Uni-Lock Wheel Lock	72
Replacing the Uni-Lock Wheel Lock	72
Changing the Uni-Lock From the Push to the Pull Position	72
Repositioning The Handle For Your Uni-Lock Wheel Lock	73
Standard Handle Positions 1, 2, 3	73
Reversed Handle Positions 1, 2, 3	74
Uni-Lock with Extension Handles (TR Series, YG Series, YR Series, ZR Series, Aero Z and Evo)	74
Composite Scissor Lock (TR Series, YG Series, YR Series, ZR Series, Aero Z and Evo)	74
Adjusting the Composite Scissor Lock	74
Replacing the Composite Scissor Lock	74
Removing the Scissor Lock Spring	75
CHAPTER 11: CASTERS, FORKS AND CASTER PIN LOCKS	76
Front Casters and Forks (YG Series, TRA, YRA, Evo and BB)	76
Replacing Front Casters	76
Replacing Front Fork Assemblies	76

Front Casters and Forks (ZR Series, Aero Z, TR and YR)	77
Replacing Front Casters	77
Replacing Front Forks	78
Adjusting Front Seat Height	78
Caster Pin Locks (TR Series, YG Series, YR Series and Evo)	78
To engage the caster pin lock:	78
To disengage the center pin lock:	78
Adjustable Angle Caster Barrel (YG Series, TRA, YRA and Evo)	79
Adjusting the Angle	79
Angle Adjustable Bearing Fork (ZRA and Aero Z)	79
Adjusting the Angle	79
ZRA and Aero Z Fork Extensions	80
Floating Casters (TR Series, YR Series, YG Series, ZR Series, Aero Z, BB and Evo) ..	80
Frog Legs® (TR Series, YG Series, YR Series, ZR Series, Aero Z and Evo)	82
Replacing the Elastomer Shock	82
CHAPTER 12: REAR WHEELS	83
Rear Wheel with Quick Release Axles (All Models)	83
Removing	83
Replacing	83
Rear Wheel With Quad Release Axle	83
Removing	83
Replacing	84
Handrims	84
Replacing the Handrim	84
Rear Wheel Spacers (TR Series, YG Series, YR Series, ZR Series, Aero Z, BB and Evo)	85
Adjusting Rear Wheel Spacing	85
CHAPTER 13: ANTI-TIPS	86
Rear Anti-Tips (TR Series, YG Series, YR Series, BB, Evo, ZRA and Aero Z)	86
Adjusting	86
Mounting the Rear Anti-Tip Receptacle (ZRA and Aero Z)	86
Mounting the Rear Anti-Tip Receptacle (TRA and YRA)	86
Mounting the Rear Anti-Tip Receptacle (TR, YR and BB)	87
Mounting the Rear Anti-Tip Receptacle (Evo)	88
Mounting the Rear Anti-Tip Receptacle (YG Series)	88
Standard Titanium 5th Wheel With Single Swivel Caster (TR, YR and BB)	89
Adjusting	89
Quick Release Titanium 5th Wheel With Single Swivel Caster (TR, YR and BB)	89
Adjusting	89
5th Wheel Swivel Caster (TR, YR and BB)	90
Adjusting the Height of the 5th Wheel Swivel Caster	90
BB Front Wing (BB)	90
Adjusting The Front Wing	90
Front Anti-Tip (TR Series, YR Series, ZR Series, Aero Z, BB and Evo)	90
Removing the Front Anti-Tip	90
CHAPTER 14: YG SERIES ADJUSTABLE SEAT WIDTH AND DEPTH	91
Adjusting the Width of the Wheelchair	91
Adjusting the Seat Depth	92
TILITE LIMITED WARRANTY	93

CHAPTER 1: WARNINGS

GENERAL WARNINGS

A. SAFETY INSPECTIONS AND MAINTENANCE

WARNING

It is important to keep your wheelchair in proper working condition. Chapter 2 of this Manual outlines the safety inspections that you should make before each use of your chair as well as weekly, quarterly and annual inspections.

1. ALWAYS inspect and maintain your TiLite wheelchair strictly in accordance with the instructions and charts in Chapter 2.
2. If you detect a problem in the course of your inspections or maintenance, ALWAYS have the chair serviced or repaired to correct the problem **BEFORE** using the chair.
3. ALWAYS have your chair completely inspected and serviced by an authorized TiLite supplier at least once a year.
4. ALWAYS perform your safety inspections and any maintenance or adjustments while the chair is unoccupied.

If you fail to inspect or maintain your wheelchair as directed in this Manual, you may fall, tip over or lose control of the wheelchair and seriously injure yourself or others or damage the wheelchair.

B. ACCLIMATING TO YOUR NEW CHAIR

WARNING

Each wheelchair is a unique piece of medical equipment, with unique handling, maneuvering and ride characteristics. Whether you are a new wheelchair user or have years of experience, you **MUST** take the time to acclimate to this particular chair before you begin riding. Start slowly and take the time to learn the handling, maneuvering and ride characteristics of this chair. For example, your previous chair may have been a heavier and less responsive chair, and, therefore, you may be used to using more force than is necessary to maneuver your TiLite chair. *If you use too much force, you may fall, tip over or lose control of the wheelchair and seriously injure yourself or others or damage the wheelchair.*

C. WEIGHT LIMITATION

WARNING

TiLite wheelchairs have a weight limit of 250 pounds (113.6 kilograms). This weight limitation applies to the combined weight of the user and any items carried by the user. **DO NOT** exceed this weight limit. *If you exceed the limit, you may fall, tip over or lose control of the wheelchair and seriously injure yourself or others or damage the wheelchair.*

D. PREVENTING ACCIDENTS AND INJURIES

WARNING

1. You **MUST** be properly and fully trained in the safe use of this wheelchair by your health care advisor **BEFORE** you use this chair.
2. Together with your health care advisor, you **MUST** analyze your level of function and ability and develop your own methods for safe use that best suit you based on your level of function and ability.
3. You **MUST** learn the limits of your ability and operate this wheelchair within such limits. This means you must **PRACTICE** the maneuvers you will need to perform, such as bending, reaching and transfers, until you know the limits of your ability. ALWAYS practice with the assistance of someone who can help you until you know what can cause, and how to avoid, a fall or tip-over. **NEVER** try a new maneuver on your own until you are sure you can do it safely.
4. ALWAYS learn as much as you can about the places where you will be using your chair before you get there. ALWAYS be alert for hazards and learn how to avoid them.

5. Anti-Tippers **MUST** be used with your wheelchair at all times. Because anti-tippers are an option on this wheelchair, TiLite strongly recommends you order the anti-tippers as they are an important safeguard for the wheelchair user.
6. Together with your health care advisor, you **MUST** analyze your medical condition to determine whether you are capable of using this chair safely and/or what options or accessories you will require in order to use this chair safely (e.g., pressure-relief cushions, seat belts).

If you ignore these Warnings, you may fall, tip over or lose control of the wheelchair and seriously injure yourself or others or damage the wheelchair.

E. CHANGING/ADJUSTING YOUR WHEELCHAIR

WARNING

1. Use extreme caution when changing or adjusting the configuration of your TiLite wheelchair. When you change or adjust the configuration, you may increase the risk of a tip-over. Therefore, you should consult your authorized TiLite dealer **BEFORE** you change or adjust the configuration. Further, TiLite recommends that you use anti-tippers at all times, and this is particularly true after you have changed or adjusted the configuration of your chair.
2. Unauthorized modifications to your chair, or the use of parts not supplied or approved by TiLite, may change the chair structure, may cause a safety hazard, including an increased risk of a tip-over, and will void the warranty.

If you ignore these Warnings, you may fall, tip over or lose control of the wheelchair and seriously injure yourself or others or damage the wheelchair.

F. ENVIRONMENTAL FACTORS

WARNING

1. Riding your TiLite wheelchair on a wet, icy or other slick surface increases the risk of losing control of the wheelchair or tipping over. Use extra care if you must ride your chair on any such surface. If you have any doubt about your ability to negotiate a particular surface, **ALWAYS** ask for assistance.
2. Titanium does not rust or corrode. However, contact with water or excess moisture may still damage parts or components of your TiLite wheelchair that are made from other materials and could cause such parts or components to fail. Therefore, **DO NOT**:
 - a. use your chair in a shower, pool or other body of water,
 - b. leave your chair in a damp location, or
 - c. fail to dry your chair as soon as you can if it gets wet or if you use water to clean it.

If you ignore these Warnings, you may fall, tip over or lose control of the wheelchair and seriously injure yourself or others or damage the wheelchair.

G. STREET USE

WARNING

1. As a wheelchair rider, you **MUST** obey all traffic rules pertaining to pedestrians (use of crosswalks, etc.). Most states do not permit wheelchairs to be ridden on public roads, streets or highways (i.e., as one would drive a car), so you should not do so without first consulting the traffic laws in your own state. Even if legal, riding your wheelchair on public roads, streets or highways is extremely dangerous and is not recommended.
2. At all times when riding your wheelchair in public areas (sidewalks, crosswalks, parking lots, etc.), be very alert to the danger of motor vehicles.
3. At night, or when lighting is poor, use reflective tape on your chair and clothing.

4. Due to your low position, it may be hard for drivers to see you. This is particularly true in situations where drivers may be driving in reverse, such as parking lots. If at all possible, make eye contact with drivers before you go forward. When in doubt, yield until you are sure it is safe, even if you have the right-of-way.

If you ignore these Warnings, you may fall, tip over or lose control of the wheelchair and seriously injure yourself or others or damage the wheelchair.

H. TERRAIN

WARNING

Your TiLite wheelchair is designed for riding over firm, relatively smooth surfaces such as concrete and asphalt outdoors and indoor flooring (wood, tile, etc.) and carpeting. Your TiLite wheelchair is NOT designed for riding over sand, loose soil or rough terrain. Do NOT operate your chair in such terrain. You may damage the wheels or axles or loosen fasteners of your chair.

If you ignore these Warnings, you may fall, tip over or lose control of the wheelchair and seriously injure yourself or others or damage the wheelchair.

I. MOTOR VEHICLE SAFETY

WARNING

TiLite wheelchairs are NOT designed to be used for seating in a motor vehicle, and TiLite wheelchairs do NOT meet Federal standards for motor vehicle seating.

1. NEVER sit in your chair while in any type of moving vehicle (motor vehicle, boat, train, etc.). In an accident or sudden stop, you may be thrown from the chair. In an accident or sudden stop, a wheelchair seat belt will NOT prevent injuries and may, in fact, cause injuries.
2. ALWAYS transfer to an approved vehicle seat before the vehicle begins moving.
3. ALWAYS secure yourself in the approved vehicle seat using the proper seating restraints (in a motor vehicle, lap/shoulder belts; in a plane, lap belts, etc.).
4. NEVER transport your chair in the front seat of a vehicle. Movements of the vehicle may cause the chair to shift and interfere with the driver's ability to control the vehicle.
5. When transporting your chair in a moving vehicle, ALWAYS secure your chair so that it cannot roll or shift. In most cases, stowing it in the trunk is the safest alternative.
6. NEVER use any chair that has been involved in a motor vehicle accident. A wheelchair that has been involved in a motor vehicle accident may be damaged in ways that are not readily apparent and which could cause the chair to fail in use.

If you ignore these Warnings, you may fall, tip over or lose control of the wheelchair and seriously injure yourself or others or damage the wheelchair.

J. WEIGHT TRAINING

WARNING

NEVER use your TiLite wheelchair for weight training. When your chair was set up with the assistance of your health care advisor, your center of gravity was determined based on your weight, the configuration of your chair and your abilities. If you engage in weight training activities in your chair, you are altering the total weight supported by your chair and the distribution of that weight. The center of gravity of your chair may not be appropriate with the additional weight or with the different distribution of weight, which may cause the chair to tip over. If you intend to engage in weight training, TiLite recommends that you utilize weight training equipment with built-in seating and that you transfer to that seating rather than using your chair.

If you ignore these Warnings, you may fall, tip over or lose control of the wheelchair and seriously injure yourself or others or damage the wheelchair.

K. OBTAINING ASSISTANCE

WARNING

For The Wheelchair User:

ALWAYS make sure that each person who assists you reads and understands this entire Manual, especially the Warnings in this Chapter 1.

For Attendants/Assistants:

1. ALWAYS work with the user's health care advisor to learn safe methods to assist the wheelchair user and to determine which methods are best suited to your abilities and those of the user.
2. ALWAYS communicate to the user what you plan to do before you do it and explain what you expect the user to do while you are taking such action. This will put the user at ease and reduce the risk of an accident due to a miscommunication.
3. ALWAYS use good posture and proper body mechanics in order to avoid injury to your back.
4. When you lift or support the user or tilt the chair, ALWAYS bend your knees slightly and keep your back as upright and straight as you can.
5. Wheelchair push handles are designed to provide a secure location for an attendant to grip the rear of the wheelchair to prevent a fall or tip-over. ALWAYS make sure the wheelchair has push handles and ALWAYS use them. REGULARLY check to make sure the push handle grips are securely seated on the back canes so they will not rotate or slip off.
6. If you are going to tilt the chair backward, ALWAYS remind the user to lean back.
7. If you are going to descend a curb or single step, ALWAYS lower the chair slowly in one easy movement. NEVER let the chair drop the last few inches to the ground. This may damage the chair or injure the user.
8. ALWAYS become familiar with the user's wheelchair and all of its parts and components. In particular, be very aware of any removable parts. Removable parts must NEVER be used for a hand-hold or lifting supports because they may inadvertently release, resulting in possible injury to the user and/or assistant.
9. Anti-tippers may present a tripping hazard to the attendant. To avoid tripping over the anti-tippers, unlock and rotate anti-tip tubes up, out of the way. However, if you must leave the user unattended, even for a moment, ALWAYS rotate the anti-tippers back into the down position and lock the rear wheels. This will reduce the risk of a tip-over or loss of control of the chair.
10. When you are learning a new assistance technique, ALWAYS have an experienced attendant help you before attempting it on your own.

If you ignore these Warnings, you may fall, tip over or lose control of the wheelchair and seriously injure yourself or others or damage the wheelchair.

L. STANDING ON YOUR CHAIR

WARNING

Your TiLite wheelchair has been designed for use as a wheelchair, not as a step ladder. NEVER stand on your TiLite wheelchair.

If you ignore these Warnings, you may fall, tip over or lose control of the wheelchair and seriously injure yourself or others or damage the wheelchair.

WARNINGS FOR SAFE USE OF YOUR WHEELCHAIR

A. LEARNING TO DO A “WHEELIE”

WARNING

DO NOT attempt to perform a “wheelie” in your wheelchair because of the dangerous nature of this kind of maneuver.

TiLite recognizes that some wheelchair users will ignore this warning. If you should choose to ignore this warning, you should follow these steps to help learn to do a “wheelie” as safely as possible (but doing a “wheelie” is never completely safe and TiLite assumes no responsibility for any injury you may sustain as a result of doing a “wheelie”):

1. Read and follow the Warning for “WHEELIES” on pages 10-11 of this Manual.
2. NEVER attempt to learn how to do a wheelie without the assistance of someone strong enough to catch you should you start to tip over (a “spotter”). Your spotter should read and be completely familiar with this entire Manual, especially this Warning and the Warning for “WHEELIES” on pages 10-11 of this Manual.
3. Instruct your spotter to stand at the rear of your chair. Your spotter must be agile enough to move with you and your chair to prevent a tip-over.
4. Instruct your spotter to keep his or her hands BENEATH the push handles or backrest rigidizer bar so that he or she is ready to catch you if you exceed the balance point of the rear wheels and start to tip over backward.
5. When your spotter is in position and is ready, place your hands on the forward portion of the handrims. Using the handrims, make a quick BACKWARD movement of the rear wheels, quickly followed by a hard FORWARD thrust. This will tilt the chair up on the balance point of the rear wheels. DO NOT remove your hands from the handrims after either the backward movement or forward thrust so that you can continue to manipulate the rear wheels to maintain your balance on the two rear wheels.
6. Use SMALL movements of the handrims to maintain your balance on the two rear wheels.

If you ignore these Warnings, you may fall, tip over or lose control of the wheelchair and seriously injure yourself or others or damage the wheelchair.

B. CLIMBING A CURB OR SINGLE STEP

WARNING

1. NEVER attempt to negotiate a curb or single step without assistance.
2. Instruct your assistant to stand at the rear of your wheelchair, with the front of the wheelchair facing the obstacle. NEVER attempt to negotiate any such obstacle backward.
3. Instruct your assistant to tilt the chair up on the rear wheels so that the front casters clear the curb or step.
4. Instruct your assistant to slowly move the chair forward and to gently lower the front casters to the upper level as soon as you are sure that they are beyond the edge of the curb or step.
5. Instruct your assistant to continue to roll the chair forward until the rear wheels contact the face of the curb or step.
6. Instruct your assistant to lift and roll the rear wheels up to the upper level.

If you ignore these Warnings, you may fall, tip over or lose control of the wheelchair and seriously injure yourself or others or damage the wheelchair.

C. CLIMBING A FLIGHT OF STAIRS

WARNING

TiLite does not recommend that its wheelchairs be transported up or down stairways with the user in the wheelchair.

However, TiLite recognizes that wheelchair users may, on occasion, have no other choice. Only if you have no alternative, you should follow these steps to climb up a flight of stairs.

1. NEVER attempt to negotiate more than one step unless you have two (2) able-bodied adult assistants.
2. ALWAYS position the chair and rider facing away from the stairs, with one assistant at the rear (facing away from the stairs) and one at the front of the chair (facing the rider).
3. The assistant at the rear of the chair is in control of this procedure. He or she must tilt the chair back to its balance point on the rear wheels. NEVER attempt to lift a wheelchair by lifting on any removable (detachable) parts, including upholstery.
4. The second assistant at the front must firmly grasp a non-detachable part of the front frame with both hands and lift the chair up and over one stair at a time.
5. Each assistant then carefully moves up to the next stair.
6. Repeat steps 1 through 5 for each stair, until you reach the landing.
7. When you reach the landing, the assistants should roll the chair backward on the two rear wheels until the front casters have cleared the last step, at which point the assistants can gently lower the front casters to the landing.

If you ignore these Warnings, you may fall, tip over or lose control of the wheelchair and seriously injure yourself or others or damage the wheelchair.

D. DESCENDING A CURB OR SINGLE STEP

WARNING

1. NEVER attempt to negotiate a curb or single step without assistance.
2. When you are still several feet from the edge of the curb or step, instruct your assistant to stand at the rear of your wheelchair and turn it around so you are facing AWAY from the obstacle.
3. NEVER attempt to negotiate any such obstacle facing forward.
4. Instruct your assistant to carefully step backwards, pulling the chair backwards, until he or she is off the curb or stair and standing on the lower level. The assistant should watch his or her step over his or her shoulder when backing up in this manner.
5. Instruct your assistant to carefully pull the chair backward until the rear wheels reach the edge of the curb or step, and to then allow the rear wheels to slowly roll down to the lower level.
6. Instruct your assistant that, when the rear wheels are safely on the lower level, he or she may then tilt the chair backward to the balance point of the rear wheels, thereby raising the front casters off the upper level.
7. Instruct your assistant to slowly roll the chair backward on the rear wheels, taking small steps until the front casters have cleared the step or curb and, when clear, to gently lower the front casters to the ground at the lower level.

If you ignore these Warnings, you may fall, tip over or lose control of the wheelchair and seriously injure yourself or others or damage the wheelchair.

E. DESCENDING A FLIGHT OF STAIRS

WARNING

TiLite does not recommend that its wheelchairs be transported up or down stairways with the user in the wheelchair.

However, TiLite recognizes that wheelchair users may, on occasion, have no other choice. Only if you have no alternative, you should follow these steps to descend a flight of stairs.

1. NEVER attempt to negotiate more than one step unless you have two (2) able-bodied adult assistants.
2. ALWAYS position the chair and rider facing down the stairs, with one assistant at the rear (facing down the stairs) and one at the front of the chair (facing the rider).
3. The assistant at the rear of the chair is in control of this procedure. He or she must tilt the chair back to its balance point on the rear wheels and roll it to the edge of the first step. NEVER attempt to lift a wheelchair by lifting on any removable (detachable) parts, including upholstery.
4. The second assistant at the front must stand at the third step from the top and firmly grasp a non-detachable part of the front frame with both hands. The second assistant must lower the chair one stair at a time by letting the rear wheels roll over the stair edge. Each assistant then carefully moves down to the next stair.
5. Repeat steps 1 through 4 for each stair, until you reach the ground level.
6. When you reach the ground level, the first assistant should carefully lower the front casters to the ground.

If you ignore these Warnings, you may fall, tip over or lose control of the wheelchair and seriously injure yourself or others or damage the wheelchair.

WARNINGS REGARDING FALLING AND TIPPING OVER

A. CENTER OF GRAVITY—STABILITY AND BALANCE

WARNING

Most falls or tip-overs occur when you go beyond the center of gravity of you and your wheelchair. TiLite wheelchairs are designed to remain stable and upright in normal daily use and activities so long as you do not exceed the center of gravity.

Every movement you make in your chair, and the rapidity with which you move, will have an affect on your center of gravity. The more you shift your body weight and the greater the speed at which you shift it, the greater the impact on your center of gravity in your chair.

There is a point where your wheelchair will tip forward or backward or to the side—which is a function of your center of gravity in the chair—its center of balance and stability. The type of chair, the setup of your chair, the options on your chair and the changes you make to the setup or options will all affect the center of gravity and therefore the stability of the chair. As the stability decreases, the risk of a fall or tip-over increases.

Set forth below is a list of various types of adjustments that you may be able to make to your wheelchair, depending on the wheelchair model you own, and a brief description of how those adjustments will affect your center of gravity:

1. The position of the rear wheels is the most significant factor affecting your center of gravity. The more you move the rear wheels forward, the more likely your chair will tip over backward.
2. The distance between the rear wheels. The less distance between the rear wheels, the greater the likelihood your chair will tip over to the side.
3. The amount of rear wheel camber. The less camber, the greater the likelihood your chair will tip over to the side.
4. The height of your seat. As you raise the height of your seat, you raise your center of gravity and increase the likelihood of all types of tip-overs.
5. The angle of your seat. As you increase the angle of your seat (relative to the floor), your position in the chair is shifted toward the rear of the chair, increasing the likelihood your chair will tip over backward.
6. The angle of your backrest. As you increase the angle of your backrest (relative to the seat), your position in the chair is shifted toward the rear of the chair, increasing the likelihood your chair will tip over backward.
7. The height of your seat back. As you lower the height of your seat back, you make it easier to lean back in your chair, which in turn shifts your center of gravity rearward and increases the likelihood your chair will tip over backward.

Other factors will affect your center of gravity:

1. A change in your body position, posture or weight distribution. For example, if you lean forward you shift the center of gravity forward and increase the likelihood of tipping over forward.
2. Riding your chair on a ramp or slope. On an up-slope, your weight shifts to the rear and a backward tip-over becomes more likely. On a down-slope, your weight shifts to the front of the chair and a forward tip-over becomes more likely.
3. The use of a backpack or other options, and the amount of weight added by those options. For example, carrying a lot of weight in a backpack will shift the center of gravity rearward and increase the likelihood of tipping over backward. However, using a TiLite seat pouch beneath the seat sling to carry heavier items will lower your center of gravity and reduce, but not eliminate, your risk of a tip over.

In order to reduce the risk of a tip-over, you should:

1. CONSULT your doctor, nurse or therapist to find out what axle and caster position and other chair configuration options are best for you.
2. CONSULT your authorized TiLite dealer BEFORE you modify or adjust your wheelchair. Often, an adjustment you wish to make can be offset by another that you have not considered. For example, you may want to adjust the back angle rearward, which will increase the likelihood of a rear tip-over. You might not think you could counteract this tendency by moving the rear wheels backward. Your authorized TiLite dealer will be able to give you expert, personalized advice in such matters.
3. ALWAYS have someone assist you until you learn your chair's balance points and are completely comfortable in your ability to operate your chair under all conditions so as to avoid tip-overs.
4. ALWAYS use anti-tippers.

If you ignore these Warnings, you may fall, tip over or lose control of the wheelchair and seriously injure yourself or others or damage the wheelchair.

B. TRANSFERRING IN AND OUT OF YOUR WHEELCHAIR

WARNING

Transferring in or out of your wheelchair is one of the most dangerous things you can attempt relating to your wheelchair. It requires good balance, agility and upper body conditioning. At some point in every transfer, there is no wheelchair seat beneath you and the seat, bed, etc. to or from which you are transferring is not beneath you either.

Important rules that will help to reduce the risk of a fall during a transfer are discussed below:

1. ALWAYS work with your health care advisor to learn safe transfer methods.
2. ALWAYS ask your health care advisor to teach you proper body positioning during a transfer and how to support yourself during a transfer.
3. ALWAYS have someone assist you when you transfer until you have learned how to transfer safely and have developed the upper body strength and coordination to transfer safely.
4. ALWAYS move your chair as close as you can to the seat (bed, etc.) to which you are transferring. If possible, use a transfer board.
5. ALWAYS lock the rear wheels using wheel locks before you transfer. This keeps the rear wheels from rolling. If your wheelchair is equipped with caster pin locks, ALWAYS lock them before you transfer. Caster pin locks keep the front casters from moving. NOTE: Wheel locks and caster pin locks will NOT keep your chair from sliding away from you or tipping.
6. If your wheels have pneumatic (inflatable) tires, ALWAYS make sure to keep the tires properly inflated at all times. The wheel locks may slip if the tire pressure is low, which may cause the chair to roll unexpectedly during a transfer.
7. ALWAYS rotate the front casters as far forward as possible and turn them to the seat (bed, etc.) to which you are transferring.
8. ALWAYS remove the wheelchair armrests, or swing them out of the way, so they do not impede your movement during the transfer.
9. If possible, ALWAYS remove the footrests, or swing them out of the way, to ensure your feet do not get caught between the footrests. TiLite strongly recommends that you place your feet on the floor when you are transferring to or from your chair.
10. NEVER put your weight on the footrests when you are transferring to or from your chair because this may cause the chair to tip over and/or roll away.
11. When transferring into your chair, ALWAYS transfer as far back onto your seat as possible in order to reduce the risk that the chair will tip over or move away from you causing you to fall.
12. If possible, ALWAYS try to avoid falling into your chair uncontrollably when transferring into your chair. This places undue stress on your chair's components and if your chair does start to move or tip you will not be ready to regain control.

If you ignore these Warnings, you may fall, tip over or lose control of the wheelchair and seriously injure yourself or others or damage the wheelchair.

C. DRESSING/UNDRESSING IN YOUR CHAIR

WARNING

When you engage in activities while seated in your chair such as dressing or undressing or changing your clothes, your weight will shift. Since your attention may be directed to the activity in question rather than maintaining your balance, your risk of falling or tipping over is increased. To reduce this risk, get dressed or undressed or change your clothes while seated in a regular chair or on a bed. If you must get dressed or undressed or change your clothes while seated in your wheelchair:

1. ALWAYS rotate the front casters so they are as trailing forward. This makes the chair more stable. **NOTE:** To get your front casters to trail forward, first move your chair forward past the object you want to reach and, second, back up alongside the object. By moving backward, your front casters will rotate and trail forward.
2. ALWAYS lock your anti-tippers in the down position so the risk of a backward tip-over is minimized. If your chair does not have anti-tippers, back it up against a wall and lock both rear wheels using your wheel locks.
3. If your chair is equipped with caster pin locks, ALWAYS engage them.

If you ignore these Warnings, you may fall, tip over or lose control of the wheelchair and seriously injure yourself or others or damage the wheelchair.

D. BENDING/LEANING/REACHING

WARNING

When you bend, reach or lean from your chair you will affect the center of balance of your chair. Therefore, bending, reaching or leaning may cause you to fall or tip over. In order to avoid falling or tipping over, you must determine your particular safety limitations given the configuration of your chair and your body weight and type. To do this, practice bending, reaching and leaning activities (and various combinations of such activities) under the supervision of your health care advisor. Do this **BEFORE** attempting active use of your chair. The following will help you avoid falling or tipping over when bending, reaching or leaning from your chair:

1. NEVER bend, reach or lean in a way that requires you to move forward in your seat.
2. ALWAYS keep your buttocks in contact with the backrest and the seat cushion when bending, reaching or leaning.
3. NEVER shift your weight in the same direction you are bending, reaching or leaning.
4. NEVER reach or lean to the rear unless your chair has anti-tippers locked in place.
5. NEVER reach with both hands. By keeping one hand free, you may be able to catch yourself to prevent a fall if the chair starts to tip.
6. NEVER reach or lean over the top of the seat back. If you do so you may damage the seat back tubes, which could cause you to fall.
7. ALWAYS move your chair as close as possible to the object you are trying to reach.
8. NEVER shift your weight to the footrests.
9. NEVER try to pick up an object from the floor by reaching down between your knees. You are less likely to tip over if you reach to the side of your chair when picking up an object on the floor.
10. DO NOT lock the rear wheels when bending, reaching or leaning backward. Locking the rear wheels creates a tip point and makes falling or tipping over more likely.
11. When bending or leaning, ALWAYS grasp one rear wheel with one hand. This will help to prevent a fall if the chair starts to tip over.
12. ALWAYS rotate the front casters until they are trailing forward. This will make the chair more stable.
NOTE: To get your front casters to trail forward, first move your chair forward past the object you want to reach and, second, back up alongside the object. By moving backward, your front casters will rotate and trail forward.

If you ignore these Warnings, you may fall, tip over or lose control of the wheelchair and seriously injure yourself or others or damage the wheelchair.

E. MOVING BACKWARD

WARNING

When you propel backward, you will tend to shift your weight backward, making a tip-over more likely. In addition, you may be unable to see an obstruction that could block one of your wheels and cause a tip-over. Therefore, use extreme caution when propelling backward. If you must propel backward:

1. ALWAYS propel slowly with smooth, short strokes.
2. MAKE frequent stops to check for obstructions in your path.
3. If your chair has anti-tippers, ALWAYS make sure to lock them in place.

If you ignore these Warnings, you may fall, tip over or lose control of the wheelchair and seriously injure yourself or others or damage the wheelchair.

F. WHEELIES

WARNING

Balancing in your chair on just the rear wheels with the front casters in the air is known as doing a “wheelie.” **DOING A WHEELIE IS DANGEROUS.** A fall or tip-over is very likely. However, if you can do a “wheelie” safely, you may be able to overcome curbs and obstacles that would otherwise impede you.

NEVER attempt to learn to do a “wheelie” without first consulting your health care advisor to make sure you are a good candidate to learn to do a “wheelie.” NEVER attempt to learn to do a “wheelie” without an assistant that can catch you if you should happen to start to fall. NEVER attempt to learn to do a “wheelie” unless you are a skilled rider of this chair.

If you ignore these Warnings, you may fall, tip over or lose control of the wheelchair and seriously injure yourself or others or damage the wheelchair.

G. OBSTACLES

WARNING

When riding outdoors, uneven pavement, sidewalk irregularities, potholes and other obstacles and road hazards can be dangerous. When riding indoors, doorway thresholds, plush carpeting and other obstacles can be dangerous. In order to avoid these risks:

1. ALWAYS be alert for such dangers.
2. ALWAYS scan the area ahead of you as you ride.
3. REMOVE or cover threshold strips between rooms.
4. INSTALL ramps at entry or exit doors from your residence. Make sure the transition from such ramps to the pavement or other surface is smooth and does not have an abrupt drop-off.
5. ALWAYS make sure the floors where you live and work are level.
6. KEEP all floors where you live and work free of obstacles and hazards.
7. When riding UP and over an obstacle, lean your upper body slightly FORWARD.
8. When riding DOWN from a higher to a lower level, press your upper body BACKWARD lightly.
9. ALWAYS keep both hands on the handrims as you go over an obstacle.
10. NEVER push or pull on any object, such as a door knob or door jamb or furniture, in order to propel your chair.
11. If your chair has anti-tippers, lock them in place before you go UP over an obstacle.

If you ignore these Warnings, you may fall, tip over or lose control of the wheelchair and seriously injure yourself or others or damage the wheelchair.

H. CURBS/STEPS

WARNING

Curbs and steps are extremely dangerous obstacles.

1. NEVER attempt to go up or down a curb or step without an assistant UNLESS:
 - a. you are a very skilled rider of your chair; and
 - b. you have previously learned to safely do a “wheelie” in your chair; and
 - c. you are sure you have the strength and balance to control your chair during any such maneuver.
2. ALWAYS unlock and rotate anti-tippers up and out of the way so they do not prevent you from executing this maneuver.
3. Even if you are a highly skilled rider, NEVER attempt to climb or descend a high curb or step (more than 4” high).
4. ALWAYS go straight up or down a curb or step. NEVER climb or descend at an angle.
5. ALWAYS be aware that the impact of dropping down from a curb or step can damage your chair or cause components to become loose. If you perform such maneuvers, inspect your chair more frequently.

If you are not highly skilled at tilting the chair, or the step or the curb is more than 4” high, ALWAYS have an assistant help you negotiate curbs and steps. Your assistant must first read this Manual in its entirety, especially the sections titled “Climbing a Curb or Single Step”, “Climbing a Flight of Stairs”, “Descending a Curb or Single Step” and “Descending a Flight of Stairs” on pages 5-7.

If you ignore these Warnings, you may fall, tip over or lose control of the wheelchair and seriously injure yourself or others or damage the wheelchair.

I. HILLS/SLOPES/RAMPS

WARNING

The center of balance of your chair is affected by the slope of the surface over which you are riding. Because your center of balance will be affected, your chair will be less stable when it is at an angle. This is especially true when riding on a slope sideways. Furthermore, do not assume anti-tippers will prevent a fall or tip-over under these conditions. The following rules may help to avoid a fall or tip-over:

1. ALWAYS go up or down a slope, hill or ramp as straight as possible. If you try to cut the corner, you will be traversing the slope, hill or ramp sideways to the slope and your risk of tipping over sideways will increase.
2. NEVER use your chair on a slope greater than 10%—a slope with an elevation greater than one foot in height for every ten feet in length.
3. NEVER stop on a steep slope. If you stop on a steep slope, you may not be able to maintain control of the chair.
4. NEVER use rear wheel locks as a brake to slow or stop your chair. Wheel locks are NOT brakes. Doing so will most likely cause the chair to veer out of control.
5. NEVER try to turn around or change direction when going up or down a slope.
6. ALWAYS stay in the CENTER of a ramp.
7. NEVER start up or down a ramp unless you are certain the ramp is wide enough for its entire length so your wheels will not fall off the edge.
8. In order to control your speed, ALWAYS keep pressure with your hands on the handrims when going down a hill, slope or ramp. If you go too fast, you may lose control of your chair.
9. ALWAYS lean or press your body in the UPHILL direction. This will help shift your weight to counteract the change in the center of balance caused by the hill, slope or ramp.
10. ALWAYS ask for assistance if you have any concerns at all about your ability to maintain safe control of your chair on a hill, slope or ramp.
11. ALWAYS be alert for wet or slippery conditions or surfaces, any changes in the grade of the slope (such as a lip, bump or depression), and any drop-off or lip at the bottom of a slope. For example, even a 3/4 inch lip at the bottom of a ramp can cause the front casters to stop and cause the chair to tip forward.
12. Ramps at your home and work must meet all legal requirements for your area, including building codes. If you are having a ramp installed at your home or work, ALWAYS make sure it complies with local legal requirements.

If you ignore these Warnings, you may fall, tip over or lose control of the wheelchair and seriously injure yourself or others or damage the wheelchair.

J. STAIRS

WARNING

NEVER use your wheelchair on stairs without the assistance of at least two (2) able-bodied assistants or attendants and ONLY AFTER such assistants or attendants have read and understand the Warnings “Climbing a Flight of Stairs” and “Descending a Flight of Stairs” on pages 6-7.

If you ignore these Warnings, you may fall, tip over or lose control of the wheelchair and seriously injure yourself or others or damage the wheelchair.

K. ESCALATORS

WARNING

NEVER use your wheelchair on an escalator, not even with an assistant or attendant.

If you ignore these Warnings, you may fall, tip over or lose control of the wheelchair and seriously injure yourself or others or damage the wheelchair.

L. ASSISTANTS AND ATTENDANTS

WARNING

Before you permit any person to assist you in any aspect of riding your wheelchair, you **MUST** require that the assistant or attendant fully read, understand and follow the Warnings contained in this Manual.

If you ignore these Warnings, you may fall, tip over or lose control of the wheelchair and seriously injure yourself or others or damage the wheelchair.

WARNINGS REGARDING COMPONENTS AND OPTIONS

A. ANTI-TIPPERS

WARNING

Anti-tippers are an optional accessory that can help to prevent your chair from tipping over backward. However, even the use of anti-tippers will not guarantee that your chair will not tip over backward. Also, they will not prevent your chair from tipping over sideways or forward.

TiLite strongly recommends you use anti-tippers with your wheelchair. This is most especially true:

1. if you are a new wheelchair rider; or
2. even if you are an experienced rider but you are switching to a new wheelchair, regardless of whether the prior chair was as lightweight as your TiLite; or
3. even if you are an experienced rider in your TiLite chair but you have made any modifications or adjustments to the configuration of your chair, such as changing the position of the front or rear wheels, changing the seat height, changing the camber or changing the seat or back angle. Any modification or change to your chair can make it easier to tip over and you should use anti-tippers until you have adapted to the modified configuration; or
4. even if you are an experienced rider in your TiLite chair but your physical condition has changed.

In order to properly use your anti-tippers, please follow the following rules:

1. Your anti-tippers should be between 1-1/2 inches to 2 inches off the ground when they are locked in place in the “down” position.
2. If your anti-tippers are set too LOW, they may “catch” on obstacles that you can expect to encounter in normal wheelchair use. If this happens, you may tip over and fall.
3. If your anti-tippers are set too HIGH, their ability to prevent a backward tip-over will be limited and they may not prevent a tip-over at all.
4. ALWAYS keep your anti-tippers locked in place in the “down” position unless:
 - a. You have an attendant (but your attendant must rotate the anti-tippers into the “down” position whenever he or she leaves you unattended in your chair, even for a moment), or
 - b. You have to climb or descend a curb or step or overcome an obstacle. Even if this is the case, only unlock the anti-tippers if you can safely climb or descend the curb or step or overcome the obstacle and make sure the anti-tippers are locked in the “up” position.

If you ignore these Warnings, you may fall, tip over or lose control of the wheelchair and seriously injure yourself or others or damage the wheelchair.

B. SEAT SLINGS/CUSHIONS

WARNING

TiLite seat slings (which are standard equipment) and foam cushions (which are optional equipment) are not designed for the relief of pressure. If you have pressure sores, or are at risk to get them, you may need a special pressure-relieving cushion or other seating system. If you have pressure sores, consult with your doctor immediately. If you are at risk to develop pressure sores, consult with your doctor as to the most appropriate seating system for you. TiLite has NO information about your medical condition and assumes no responsibility should you choose the wrong seating system for your medical needs. You MUST regularly check your seat sling while you are seated in your wheelchair to ensure that the tension is properly adjusted so that your weight does not cause the seat sling to touch the cross bar beneath the seat sling.

TiLite also offers a limited number of seat cushions manufactured by other manufacturers. However, the selection of any of these products is a decision to be made by you and your doctor. TiLite has NO information about your medical condition and assumes no responsibility should you choose the wrong seating system for your medical needs.

If you ignore these Warnings, you may develop pressure sores, which can be a life-threatening complication from wheelchair use.

C. UPHOLSTERY FABRIC

WARNING

1. If the fabric of your seat or seat back becomes worn or torn, ALWAYS replace it immediately. If you fail to do so, the seat or seat back upholstery may sag or fail.
2. The upholstery on your chair is flame retardant. Laundering or allowing the upholstery to become wet repeatedly will reduce the flame retardant qualities of the fabric.
3. DO NOT “drop down” into your chair. By placing undue force on the upholstery, you will weaken the fabric and it may become worn sooner than it otherwise would. If you do “drop down” into your chair on a regular basis, inspect and replace the upholstery more often.
4. The upholstery on your chair will weaken with age and use. Regularly inspect your upholstery for fraying, thin spots, or stretching of the fabric at the rivet holes.

If you ignore these Warnings, you may fall, tip over or lose control of the wheelchair and seriously injure yourself or others or damage the wheelchair.

D. SEATING SYSTEMS

WARNING

TiLite does not sell any seating systems specifically designed for use with TiLite wheelchairs, nor does TiLite recommend any particular seating system. If your doctor or therapist recommends that you use a seating system with your TiLite chair, always consult with an authorized TiLite dealer to determine if the recommended seating system is compatible with your TiLite chair. In addition, the following warnings must be followed:

1. If you add a seating system to your TiLite chair, you will affect its center of balance. This may cause the chair to tip over. Therefore, NEVER install a new seating system on your own. Instead, have it installed by an authorized TiLite dealer who can assist you in making other necessary adjustments to ensure your center of balance is maintained as closely as possible to what you are used to.
2. As with other changes to the configuration of your chair that affect its center of balance, if you add a seating system to your TiLite chair, ALWAYS use anti-tippers until you have fully learned to control your chair in its new configuration.
3. Keep in mind that adding a seating system also may inhibit the proper operation of a folding back (if your chair is so equipped).

If you ignore these Warnings, you may fall, tip over or lose control of the wheelchair and seriously injure yourself or others or damage the wheelchair.

E. POSITIONING OR SEAT BELTS

WARNING

Optional positioning or seat belts are intended ONLY to help you with your posture when sitting in your chair. If used improperly, positioning or seat belts can cause severe injury or even death. If your health care advisor has instructed you to use positioning or seat belts, make sure they instruct you on the proper usage of such belts, and such professional should supervise your use of such belts to ensure you can use them safely.

1. Belts must fit snugly in order to work properly. However, they must not be so snug they interfere with your breathing. Your health care advisor should be able to slide his or her open hand flat between the belt and your body.
2. Make sure you do not slide down in your chair while wearing a belt. If this should happen, you may suffer chest compression or be suffocated due to pressure from the belt.
3. Do not use a positioning or seat belt unless you are capable of removing the belts easily in an emergency. If you cannot do this, consult with your health care advisor for other options to help with your posture.
4. There are devices that help to keep you from sliding down in the seat of your wheelchair, such as a pelvic wedge. Consult with your health care advisor to find out if you need to use such a device in conjunction with positioning or seat belts to mitigate the risks described above.
5. NEVER use positioning or seat belts as a motor vehicle restraint. These types of belts are not intended to protect the wheelchair rider from the forces involved in a vehicle accident, and they may, in fact, cause you to be injured. TiLite recommends wheelchair users ALWAYS transfer to appropriate motor vehicle seating when traveling in a motor vehicle.

Note to Attendants/Assistants: NEVER use positioning or seat belts as a patient restraint (a restraint requires a doctor's order) or on a wheelchair user who is comatose or agitated.

If you ignore these Warnings, you may fall, tip over or lose control of the wheelchair and seriously injure yourself or others or damage the wheelchair.

F. ARMRESTS

WARNING

Armrests are optional equipment on TiLite wheelchairs. TiLite armrests are detachable and are not designed to support the weight of your wheelchair. Therefore, NEVER lift your chair by its armrests. If you do, they may detach, causing you to drop the chair, or you may break the armrests or cause them to become loose and break at a later time unexpectedly. ALWAYS lift your chair by grasping the non-detachable parts of the main frame.

If you ignore these Warnings, you may fall, tip over or lose control of the wheelchair and seriously injure yourself or others or damage the wheelchair.

G. FOOTRESTS

WARNING

Certain footrests are standard equipment with TiLite wheelchairs. Other, more specialized footrests, are optional equipment. The following rules should be followed with respect to footrests:

1. ALWAYS allow for AT LEAST 2 inches of clearance between the ground and the lowest point on the underside of your footrests. If you set your footrests too LOW, they may "catch" on obstacles you can expect to find in normal use of your chair. If your footrests "catch," the chair may stop and tip forward.
2. NEVER lift your wheelchair by grasping the footrests. Footrests are detachable and are not designed to support the weight of your chair. If you do, the footrests may detach, causing you to drop the chair, or you may break the footrests or cause them to become loose and break at a later time unexpectedly.

3. READ and understand the warnings under “Transferring In and Out of Your Wheelchair” on pages 8-9 of this Manual. There is important information in that section regarding your footrests and transfers.

If you ignore these Warnings, you may fall, tip over or lose control of the wheelchair and seriously injure yourself or others or damage the wheelchair.

H. REAR WHEELS

WARNING

Rear wheels are standard components on your wheelchair. The positioning of the rear wheels is a critical factor in locating the center of balance of your chair. Any change to your rear wheel position will change your center of balance. Therefore, use extreme caution when making any adjustment to the position of your rear wheels.

1. As you move the rear wheels and axles forward on your chair, you shift the center of balance FORWARD. This means it is easier for your chair to tip over backward.
2. As you move the rear wheels and axles backward on your chair, you shift the center of balance BACKWARD. This means your chair is less likely to tip-over backward. However, even if your rear wheels and axles are set as far back as possible, the chair can still tip-over backward.
3. ALWAYS consult with your health care provider to determine the best rear wheel/axle setup for you based on your weight and body type and your abilities to control the chair.
4. Once you and your health care provider have determined the best rear wheel/axle setup for you, NEVER change the setup UNLESS you are sure you are not at risk to tip over.
5. If you do change the rear wheel/axle position, you MUST adjust the positioning of the rear wheel locks to ensure they work properly to lock the rear wheels. When relocating the rear wheel locks, make sure the locking arm indents the tire by at least 1/8th inch when the wheel lock is in the “locked” position.

If you ignore these Warnings, you may fall, tip over or lose control of the wheelchair and seriously injure yourself or others or damage the wheelchair.

I. QUICK-RELEASE AXLES

WARNING

Stainless quick-release axles are a standard TiLite wheelchair component. Other axle types are optional equipment. Quick-release axles are designed to make your rear wheels easy to remove quickly. However, if not used properly, they can be dangerous:

NEVER use your chair UNLESS you are sure that both quick-release rear axles are locked into place in the axle receiver. If an axle is not fully locked into place, the rear wheel may come off during use of the chair and cause you to fall. You can tell when the axle is locked into place because the quick-release button in the center of the axle will pop out fully. It is also a good idea to pull on the wheel to double-check that the axle is securely locked as a final precaution.

If you ignore these Warnings, you may fall, tip over or lose control of the wheelchair and seriously injure yourself or others or damage the wheelchair.

J. PNEUMATIC TIRES

WARNING

Pneumatic rear tires are standard components on TiLite wheelchairs. Other types of rear tires are optional equipment. Pneumatic front tires are optional equipment on some TiLite wheelchairs.

With pneumatic tires, it is important to maintain the proper inflation. Maintaining the proper inflation will extend the life of your tires and will reduce the rolling resistance of your chair, making it easier to use.

1. Check your tires WEEKLY for proper inflation. The correct inflation level is imprinted on the tire sidewall.
2. DO NOT use your chair if any of the pneumatic tires are under-inflated or over-inflated.
3. If any tire is under-inflated, the chair may tend to veer to one side, which could cause you to lose control of the chair.
4. If a rear tire is under-inflated, the wheel lock for that wheel may not work properly and may slip, thereby allowing the wheel to turn unexpectedly.
5. An over-inflated tire may burst, thereby causing a loss of control of the chair.
6. ALWAYS have pneumatic tire inner tubes replaced by an authorized TiLite dealer.

If you ignore these Warnings, you may fall, tip over or lose control of the wheelchair and seriously injure yourself or others or damage the wheelchair.

K. REAR WHEEL LOCKS

WARNING

TiLite wheelchairs are equipped with standard rear wheel locks. Scissor locks and uni-locks are optional equipment. TiLite wheel locks are NOT designed to slow or stop a moving wheelchair - - they are NOT brakes. Wheel locks are ONLY designed to keep the rear wheels from rolling when your chair is at a complete stop.

1. NEVER attempt to “brake” by using rear wheel locks to try to slow or stop your chair when it is moving. If you do so, you will lose control of the chair and may fall.
2. ALWAYS make sure the locking arm of your wheel lock embeds into the tire at least 1/8th inch when in the locked position. If the wheel lock does not properly embed in the tire, the wheel lock may not work and the chair may roll unexpectedly.
3. ALWAYS maintain proper tire pressure. If a rear tire is under-inflated, the wheel lock for that wheel may not work properly and may slip, thereby allowing the wheel to turn unexpectedly.
4. When you transfer to or from your chair, ALWAYS set both rear wheel locks to prevent the rear wheels from rolling.

If you ignore these Warnings, you may fall, tip over or lose control of the wheelchair and seriously injure yourself or others or damage the wheelchair.

L. CASTER PIN LOCKS

WARNING

Caster pin locks are an optional accessory for TiLite wheelchairs. Caster pin locks are not designed to slow or stop a moving wheelchair - - they do not prevent the casters from turning. Caster pin locks are ONLY designed to keep the front casters from rotating within the caster barrel when your chair is at a complete stop.

1. ALWAYS make sure the locking pin on your caster pin locks fully engages with the front casters. If the caster pin lock does not properly engage, the caster pin lock may not work properly and the front casters may rotate unexpectedly.
2. When you transfer to or from your chair, ALWAYS set both rear wheel locks and both caster pin locks to prevent the rear wheels and front casters from rolling.

If you ignore these Warnings, you may fall, tip over or lose control of the wheelchair and seriously injure yourself or others or damage the wheelchair.

M. PUSH HANDLES

WARNING

Push handles are optional equipment on TiLite wheelchairs. Push handles provide secure points for an attendant or assistant to hold the rear of the chair to prevent a fall or tip-over. If you have an attendant or assistant, you should have push handles installed on your chair by TiLite. TiLite offers push handles that are integral to the back canes and bolt-on push handles. TiLite recommends that you do NOT use non-TiLite bolt-on push handles because they will damage the backrest of your TiLite chair. Your attendant or assistant should regularly check the push handle grips to make sure they fit securely and will not rotate or slip off.

If you ignore these Warnings, you may fall, tip over or lose control of the wheelchair and seriously injure yourself or others or damage the wheelchair.

N. FASTENERS

WARNING

TiLite uses only high-strength, high quality fasteners (nuts, bolts, screws and clamps) on its wheelchairs. If you replace any of these fasteners with improper or inferior fasteners, you may damage your chair or may cause it to fail unexpectedly.

1. ALWAYS use fasteners obtained from an authorized TiLite dealer.
2. REGULARLY inspect all fasteners to make sure they have not become loose. If any become loose, tighten them immediately.
3. NEVER over- or under-tighten the fasteners on your chair. Over-tightened or under-tightened fasteners may damage your chair or fail unexpectedly.

If you ignore these Warnings, you may fall, tip over or lose control of the wheelchair and seriously injure yourself or others or damage the wheelchair.

O. POWER DRIVE

WARNING

Certain manufacturers offer manual wheelchair power drive add-on products. TiLite has approved only a limited number of these products for use with TiLite wheelchairs. For more information about power add-ons approved by TiLite, contact TiLite Customer Service.

If you intend to install an approved power drive system on your TiLite chair, this must be taken into account when your chair is ordered so TiLite can manufacture your chair with a power-adaptable frame.

If you have not purchased your TiLite chair with a power adaptable frame, do not install a power drive on your TiLite chair. If you install a power drive add-on system to your TiLite chair and your chair does not have a power adaptable frame, you may damage your chair and you will void your warranty.

In addition, power drive systems are heavy and will affect the center of balance of your chair. Any change to the center of balance of your chair could cause you to lose control or fall or tip-over.

If you ignore these Warnings, you may fall, tip over or lose control of the wheelchair and seriously injure yourself or others or damage the wheelchair.

P. UNAUTHORIZED PARTS AND ACCESSORIES

NEVER use parts, accessories or adapters other than those authorized by TiLite. If you have any doubt about the compatibility of a particular part, accessory or adapter, consult with an authorized TiLite dealer or contact TiLite Customer Service.

If you ignore these Warnings, you may fall, tip over or lose control of the wheelchair and seriously injure yourself or others or damage the wheelchair.

CHAPTER 2: SAFETY INSPECTION, MAINTENANCE & TROUBLESHOOTING

Introduction

Your TiLite wheelchair is designed, engineered and built to provide you with years of exceptional performance. However, proper maintenance and regular safety inspections are essential in order to make sure your wheelchair is operating properly, safely and at maximum efficiency. In addition, proper maintenance and regular safety inspections will extend the life of your TiLite wheelchair.

Safety Inspections and Maintenance

WARNING

If you fail to inspect and maintain your wheelchair as directed in this Manual, you will be at risk for health complications or you may fall, tip over or lose control of your wheelchair and seriously injure yourself or others or damage the wheelchair.

WARNING

After making ANY adjustments or repairs to your wheelchair and after any servicing of your wheelchair, ALWAYS make sure all attachment hardware is tightened securely BEFORE using the chair. *If you ignore this Warning, you may fall, tip over or lose control of your wheelchair and seriously injure yourself or others or damage the wheelchair.*

1. You MUST inspect and maintain your TiLite wheelchair strictly in accordance with the following chart.
2. If your inspection per the chart uncovers any problem, make sure to service or repair the problem BEFORE using the wheelchair.
3. If your inspection reveals any loose, worn, bent or damaged parts, you MUST repair or replace them before using your TiLite wheelchair.
4. Clean your wheelchair ONLY in accordance with the instructions under "Cleaning" on pages 22 and 23 of this Manual.
5. Annually, or more often if necessary, you MUST have your wheelchair serviced and thoroughly inspected by a qualified TiLite dealer.
6. In addition to the maintenance and safety inspections indicated in the chart below, ALWAYS make sure that all nuts and bolts are tight before riding in your wheelchair.

Inspection Item	Initially	Weekly	3 Months
General			
➤ Make sure chair rolls straight – drag or pull to one side	✓	✓	
➤ Loose/missing/broken/worn/damaged hardware	✓	✓	
Rear Wheels			
➤ Inspect for cracked, bent or broken spokes	✓	✓	
➤ Make sure all spokes are uniformly tight	✓		✓
➤ Inspect hubs and rims for cracks and wear	✓	✓	
➤ Inspect for excessive side movement when wheel lifted and spun	✓		✓

Inspection Item	Initially	Weekly	3 Months
Quick/Quad Release Axles <ul style="list-style-type: none"> ➤ Make sure axles are free of dirt and lint ➤ Wipe axle with cloth using “dry” silicone spray as lubricant ➤ Make sure that axles lock properly in axle sleeve 	 ✓ ✓	 ✓	 ✓ ✓
Rear Tires <ul style="list-style-type: none"> ➤ Check for proper inflation as per sidewall of pneumatic tire (under-inflation will increase rolling resistance and will prevent wheel locks from properly engaging; overinflation may cause a tire to explode) ➤ Inspect for cracks, wear and flat spots 	 ✓ ✓	 ✓ ✓	
Camber Tube/Axle Sleeves <ul style="list-style-type: none"> ➤ Camber tube clamps are securely tightened ➤ Camber plugs are secure in camber tube and axle sleeves are secure in camber plug ➤ Adjustable camber system (if applicable) is securely tightened and axle sleeves extend proper distance from camber plug 	 ✓ ✓ ✓	 ✓ ✓ ✓	
Handrims <ul style="list-style-type: none"> ➤ Inspect for signs of rough edges or peeling ➤ Make sure handrims are securely attached to rim 	 ✓ ✓		 ✓ ✓
Wheel Locks <ul style="list-style-type: none"> ➤ Make sure wheel locks embed proper distance into tire and prevent chair from moving when engaged ➤ Make sure wheel locks do not interfere with tire when disengaged ➤ Make sure pivot points are free of wear and looseness 	 ✓ ✓ ✓	 ✓ ✓ ✓	
Seat Sling and Back Upholstery <ul style="list-style-type: none"> ➤ Inspect for rips or sagging ➤ Inspect fastening flaps to ensure they are securely attached ➤ Inspect while seated to ensure sling supports your weight and does not touch crosstube. 	 ✓ ✓ ✓	 ✓ ✓	 ✓
Front Casters/Forks <ul style="list-style-type: none"> ➤ Inspect wheels and tires for cracks and wear ➤ Inspect wheel/fork assembly for proper tension by spinning caster (caster should come to a gradual stop); if caster wobbles, tighten axle; if caster binds to a stop, loosen axle 	 ✓ ✓	 ✓ 	 ✓

Inspection Item	Initially	Weekly	3 Months
<ul style="list-style-type: none"> ➤ Inspect wheel/fork assembly/stem bolt to ensure that stem bolt is secure (wheel/fork assembly should not have excessive play relative to the stem bolt but should rotate freely); if necessary, tighten stem bolt ➤ Ensure that wheel bearings are clean and free from moisture ➤ If pneumatic, check for proper inflation as per the sidewall (under-inflation will increase rolling resistance and will prevent wheel locks from properly engaging; and over-inflation may cause a tire to explode) 	✓	✓	
<p>Armrests</p> <ul style="list-style-type: none"> ➤ Inspect to ensure that all hardware is securely attached 	✓		✓
<p>Footrests</p> <ul style="list-style-type: none"> ➤ Inspect to ensure that all hardware is securely attached 	✓		✓
<p>Anti-tips</p> <ul style="list-style-type: none"> ➤ Inspect anti-tip wheel for cracks and wear ➤ Inspect to ensure that anti-tip receptacle is securely attached 	✓	✓	✓
<p>Frame</p> <ul style="list-style-type: none"> ➤ Inspect for cracks 	✓		✓

Cleaning

Clean your chair regularly. Cleaning often will reveal loose or worn parts and enhance the smooth operation of your chair.

Cleaning the Frame

1. If your titanium frame came with a "Satin" finish, use a soft cloth to clean the finish. If necessary, moisten the cloth with glass cleaner. If the "Satin" finish of your chair becomes scratched, you can buff out the scratch using a Scotch Brite™ pad. Moisten the pad with water and rub it over the scratch in a circular motion. After buffing, wipe off the buffed area using a soft cloth moistened with glass cleaner or wood furniture polish. **Note:** Do NOT use a Scotch Brite™ pad on the logo, and NEVER use steel wool to clean your frame.
2. If your titanium chair came with a "Polished" finish, use a soft cloth to clean the finish. If necessary, moisten the cloth with glass cleaner. **Note:** NEVER use Scotch Brite™ pads or steel wool on a polished frame.
3. If your chair has a painted aluminum frame, use a soft clean cloth with soap and water to clean the frame. Immediately dry all components and parts that become wet. **Note:** Do NOT use Scotch Brite™ pads, steel wool, abrasive cleaners or petroleum-derived products to clean a painted aluminum frame.

Cleaning the Upholstery

1. Regularly hand-wash the seat sling and back upholstery using water and a mild detergent. Always air dry the upholstery.
2. NEVER machine wash the upholstery, and NEVER machine dry the upholstery.
3. When washing the upholstery, carefully check for sagging, rips or tears. If you find any rips or tears, you MUST order new upholstery.
4. After washing the seat sling, always check the tension while seated in the chair to ensure the sling does not touch the cross tube beneath the seat sling.

Axles and Moving Parts

Clean axles and other moving parts weekly with a slightly damp cloth. The cloth should not be wet. Try to wipe away any lint, dust or dirt on these parts that could interfere with their smooth operation. DO NOT use WD-40®, 3-in-1 oil®, or other penetrating lubricants on quick-release or quad-release axles. Instead, as indicated in the chart under “Safety Inspections and Maintenance”, ALWAYS use a “dry”, Teflon®-based lubricant.

Storage

1. Always store your chair in a clean, dry location. Excessive dirt can cause moving parts to become damaged or fail. Moisture can rust or corrode the non-titanium components of your chair.
2. Always fully inspect your chair after it has been stored for any period of time before riding in it. See the chart under “Safety Inspections” on pages 20-22 of this Manual.
3. If you store your chair for more than three (3) months, have your chair inspected by an authorized TiLite supplier.

Troubleshooting

Your TiLite wheelchair is a precision engineered product. To ensure your chair continues to operate at peak performance, you will need to make minor adjustments from time to time—especially if you alter the original factory settings. The chart below provides advice on solving some of the more common “adjustment” issues you may experience. If the solutions below do not solve your problem or if you experience a problem not addressed below, please contact an authorized TiLite supplier or TiLite Customer Service. Please note, if more than one solution in the chart below applies to your particular adjustment issue, always try one solution at a time until the problem is solved.

Chair Veers Right or Left	Caster Flutter	Looseness in Chair	Squeaks and Rattles	Sluggish Turning or Performance	Floating Caster	Solution
✓	✓			✓	✓	If you have pneumatic front and/or rear tires, make sure that the tires are properly and equally inflated
	✓	✓	✓	✓		Make sure that all nuts and bolts are securely tightened
		✓	✓			Make sure that all spokes and nipples are uniformly tight on all spoked wheels
✓	✓			✓	✓	Make sure that front caster barrels and mounts are properly adjusted
	✓	✓	✓	✓		Make sure that rear wheels are equally spaced away from the seat frame
✓				✓		Adjust the toe-in/toe-out of the rear wheels

CHAPTER 3: FOOTRESTS

WARNING

Check all clamps, screws, nuts and bolts that secure the footrest to the wheelchair frame to make sure they are securely tightened before using the wheelchair. *If you ignore this Warning, the footrests could move unexpectedly while you are using the chair, causing you to fall, tip over or lose control of the wheelchair and seriously injure yourself or others or damage the wheelchair.*

WARNING

On several TiLite wheelchairs, a titanium open loop footrest is available as an option. A footrest cover is recommended for wheelchair users that have leg spasticity or whose feet have a possibility of falling through an open loop footrest. *If you ignore this Warning, you could fall, tip over or lose control of the wheelchair and seriously injure yourself or others or damage the wheelchair.*

WARNING

A calf strap is offered as an option with each wheelchair to prevent your feet from slipping backwards off of the footrest. TiLite recommends that you purchase our calf strap with your wheelchair. Always make sure the calf strap is secure when using the wheelchair. *If you ignore this Warning, you could fall, tip over or lose control of the wheelchair and seriously injure yourself or others or damage the wheelchair.*

WARNING

Whenever you adjust the angle or height of your footrest, or you replace your footrest, always allow at least 2" of ground clearance to permit you to maneuver over objects. *If you ignore this Warning, you could fall, tip over or lose control of the wheelchair and seriously injure yourself or others or damage the wheelchair.*

Safe Tread

(All Models)

If you ordered your wheelchair with either the Titanium Footrest with Flat ABS Cover or the Titanium Open Loop Footrest, enclosed with your chair are two 4" squares of self-adhesive Safe Tread. Safe Tread provides a more slip-resistant surface than the footrest of your chair. Use of the Safe Tread is optional, but TiLite recommends you use it in order to reduce the likelihood of your feet slipping off the footrest during use of your chair. If you choose to apply the Safe Tread to your footrest, follow the following instructions:

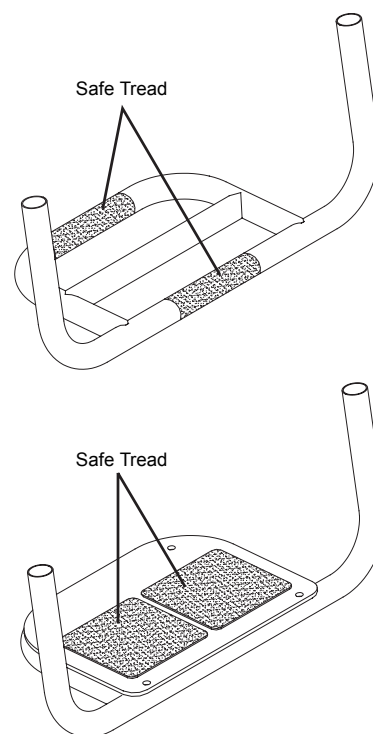

Figure 1
Footrest with Safe Tread

1. See Figure 1 for the suggested location of the Safe Tread.
2. Without removing the adhesive backing strip, position the Safe Tread on the footrest and, if necessary, use a pen or pencil to draw any edges that need to be trimmed.
3. Carefully cut the Safe Tread to size using scissors, knife or razor blade.
4. Thoroughly clean and dry the footrest.
5. Peel the adhesive strip backing from the Safe Tread and press firmly to the surface of the footrest, starting from the center and working toward the edges of the Safe Tread, making certain the edges are fully adhered.

Titanium Footrest with Flat ABS Cover (TR, YR, and BB)

Adjusting the Height of, or Replacing, the Footrest

Tools needed:

- 3/16" Allen Wrench
- Ruler

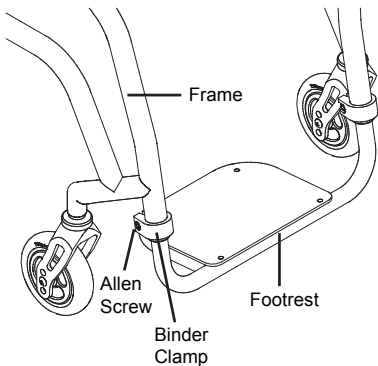

Figure 2
TR/YR/BB Titanium Footrest with Flat ABS Cover

1. Loosen the Allen Screws in the two binder clamps that secure the footrest to the frame. See Figure 2. If replacing the footrest, loosen the Allen Screws sufficiently to permit you to completely remove the old footrest and make sure to leave the plastic footrest insert sleeve inside the frame tube. If adjusting the height, loosen the Allen Screws sufficiently to permit the footrest to move up and down freely within the binder clamps.
2. If replacing the footrest, remove the old footrest and install the new footrest into the frame.
3. Place the end of a ruler on the floor and hold it vertically against the left corner of the footrest. Adjust the left side of the footrest (or the new footrest) to the desired height (not less than 2" of ground clearance) and loosely tighten the Allen Screw in the left binder clamp so the left side of the footrest cannot change. See Figure 3.
4. Repeat the procedure from step 3 above on the right side of the footrest (or the new footrest).
5. When both sides are set at an equal distance from the floor, make sure all four (4) wheels are in contact with the floor and then fully tighten the two Allen Screws in the binder clamps that secure the footrest to the wheelchair frame.

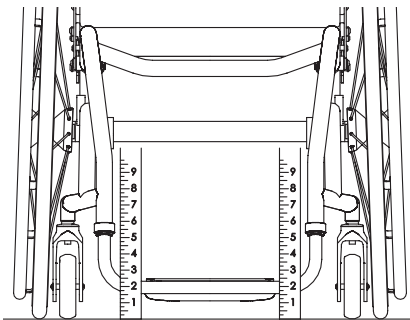

Figure 3
TR/YR/BB Titanium Footrest Height Adjustment

Titanium Footrest with Flat ABS Cover (ZR Series)

Adjusting the Height of the Footrest

Tools Needed:

- 5/32" Allen Wrench
- Plastic Mallet
- Ruler

1. Loosen the Allen Screws in the two clamps that secure the footrest to the frame. See Figure 4. Loosen each Allen Screw until the entire head of the screw is completely visible outside the clamp.
2. Tap the head of each screw with a plastic mallet to release the wedge inside the frame tube. This will allow the footrest to move freely.
3. Place the end of a ruler on the floor and hold it vertically against the left corner of the footrest. See Figure 5. Adjust the left side of the footrest to the desired height (not less than 2" of ground clearance) and tighten the Allen Screw in the left clamp so the left side of the footrest cannot change.
4. Repeat the procedure from step 3 above on the right side of the footrest.
5. When both sides are set at an equal distance from the floor, make sure all four wheels are in contact with the floor and then fully tighten the two Allen Screws in the clamps that secure the footrest to the chair frame, making sure the clamp remains securely butted up against the end of the frame tube.

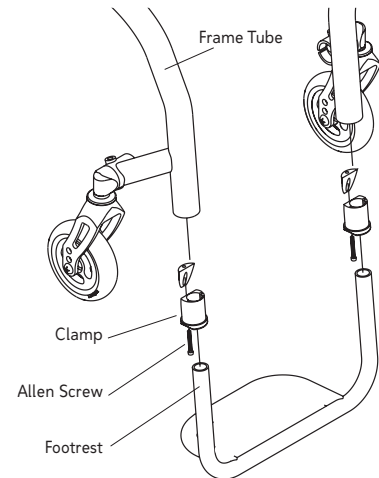

Figure 4
ZR Series Titanium Footrest Replacement

Replacing the Footrest

Tools Needed:

- 5/32" Allen Wrench
- Plastic Mallet
- Ruler

1. Loosen the Allen Screws in the two clamps that secure the footrest to the frame. See Figure 4. Loosen each Allen Screw until the entire head of the screw is completely visible outside the clamp.
2. Tap the head of the screw with a plastic mallet to release the wedge inside the frame tube. This will allow the footrest (along with the clamp, wedge and Allen Screw) to be completely removed.
3. Insert the new footrest into one clamp and, holding the wedge in place against the clamp, partially screw the Allen Screw into the clamp and the wedge. Repeat this procedure with the other clamp and wedge.
4. Slide both clamps into both frame tubes until each clamp is securely butted against the end of each frame tube.
5. Place the end of a ruler on the floor and hold it vertically against the left corner of the footrest. See Figure 5. Adjust the left side of the footrest to the

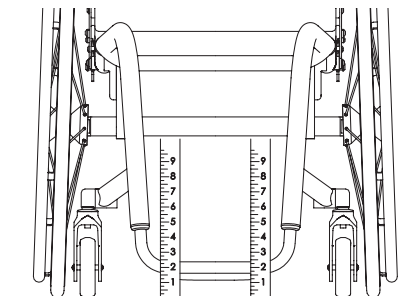

Figure 5
ZR Series and Aero Z Titanium Footrest Height Adjustment

- desired height (not less than 2" of ground clearance) and tighten the Allen Screw in the left clamp so the left side of the footrest cannot change.
6. Repeat the procedure from step 5 above on the right side of the footrest.
 7. When both sides are set at an equal distance from the floor, make sure all four wheels are in contact with the floor and then fully tighten the two Allen Screws in the clamps that secure the footrest to the chair frame, making sure the clamp remains securely butted up against the end of the frame tube.

Titanium Footrest with Flat ABS Cover (Aero Z)

Adjusting the Height of, or Replacing, the Footrest

Tools Needed:

- 1/8" Allen Wrench
- Ruler

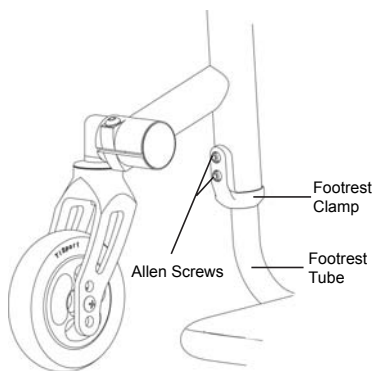

Figure 5.1
Aero Z Footrest Adjustment/Replacement

1. Loosen the two Allen Screws in the left and right footrest clamps that secure the footrest tube to the frame. See Figure 5.1. Loosen the screws sufficiently to permit the footrest tubes to slide up and down within the footrest clamps. Do not detach the footrest clamps from the frame.
2. If replacing the footrest, remove the old footrest and insert the new footrest tubes into the frame.
3. Place the end of a ruler on the floor and hold it vertically against the corner of the footrest. See Figure 5. Adjust the footrest to the desired height (not less than 2" of ground clearance) and tighten the Allen Screws in the left and right clamp so the left footrest cannot change.
4. When both sides are set, fully tighten the two Allen Screws in each clamp that secures the footrests to the chair frame, making sure the clamp remains securely butted up against the end of the frame tube.

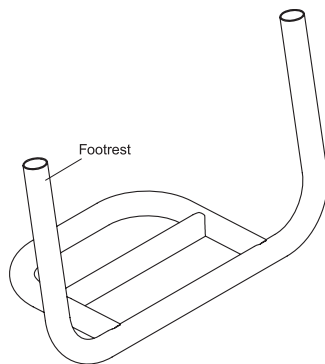

Figure 6
Titanium Open Loop Footrest

Titanium Open Loop Footrest (TR, YR and BB)

The Titanium Open Loop Footrest (see Figure 6) can be replaced or the height adjusted by using the tools and following the procedures under "Titanium Footrest with Flat ABS Cover (TR, YR and BB)" on page 25.

Titanium Open Loop Footrest (ZR Series)

The Titanium Open Loop Footrest (see Figure 6) can be replaced or the height adjusted by using the tools and following the procedures under "Titanium Footrest with Flat ABS Cover (ZR Series)" on pages 26-27.

Titanium Open Loop Footrest (Aero Z)

The Titanium Open Loop Footrest (see Figure 6) can be replaced or the height adjusted by using the tools and following the procedures under “Titanium Footrest with Flat ABS Cover (Aero Z)” on page 27.

Angle Adjustable Footrest (TR Series, YR Series, ZR Series, Aero Z, BB and Evo)

Adjusting the Angle of the Footrest

Tools needed:

- 5/32" Allen Wrench
- 7/16" Allen Wrench

1. Loosen, but do not remove, the two Allen Screws that secure the footplate to the clamp. See Figure 7.
2. Adjust the footrest to desired angle. See Figure 8.
3. Tighten the Allen Screws, making sure the screws and the lock nuts are secure and will not permit the footplate to move up or down under weight.

Replacing or Adjusting the Height of the Footrest

The Angle Adjustable Footrest (see Figure 8) for TR Series, YR Series, Evo and BB chairs can be replaced or the height adjusted by using the tools and following the procedures under “Titanium Footrest with Flat ABS Cover (TR, YR and BB)” on page 25.

The Angle Adjustable Footrest (see Figure 8) for ZR Series chairs can be replaced or the height adjusted by using the tools and following the procedures under “Titanium Footrest with Flat ABS Cover (ZR Series)” on pages 26-27.

The Angle Adjustable Footrest (see Figure 8) for Aero Z chairs can be replaced or the height adjusted by using the tools and following the procedures under “Titanium Footrest with Flat ABS Cover (Aero Z)” on page 27.

Angle Adjustable High Mount Footrest (TR Series, YR Series and Evo)

(TR Series, YR Series and Evo)

Adjusting the Angle of the Footrest

Tools needed:

- 5/32" Allen Wrench
- 7/16" Allen Wrench

The angle of the Angle Adjustable High Mount Footrest for TR Series, YR Series, Evo and YG chairs can be adjusted by using the tools and following the procedures under “Angle Adjustable Footrest (TR

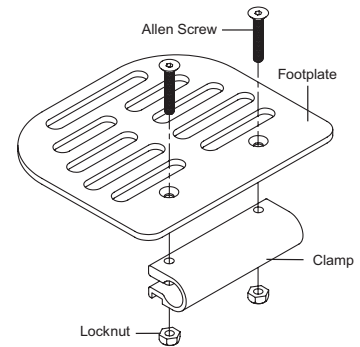

Figure 7
Adjusting the Angle of the Angle Adjustable Footrest

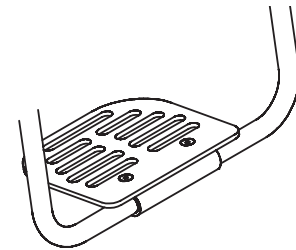

Figure 8
Angle Adjustable Footrest

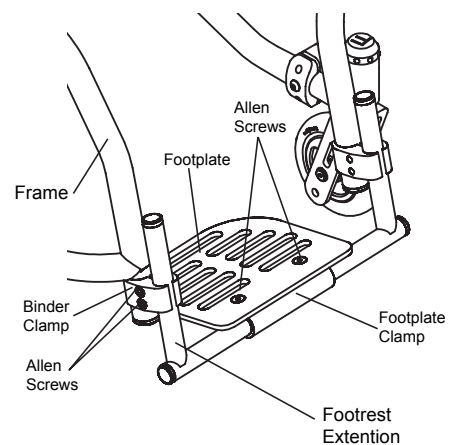

Figure 9
TR Series/YR Series/Evo/YG Angle Adjustable High Mount Footrest

Series, YR Series, ZR Series, Aero Z, BB and Evo) on page 28.

Replacing or Adjusting the Height

Tools needed:

- 3/16" Allen Wrench
- Ruler

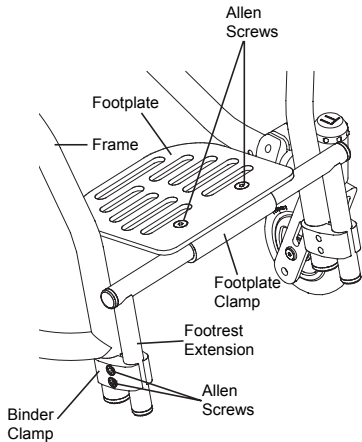

Figure 10
TR Series/YR Series/Evo/YG Angle Adjustable
High Mount Footrest in the inverted position

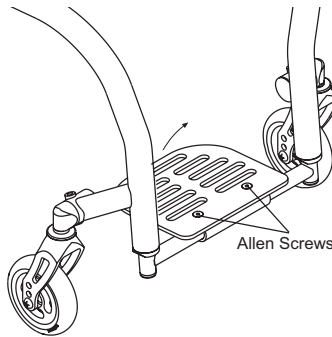

Figure 11
ZR Series and Aero Z Angle Adjustable High
Mount Footrest

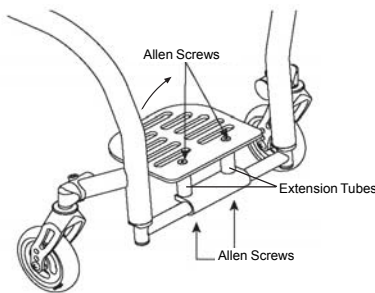

Figure 12
ZR Series and Aero Z Angle Adjustable High
Mount Footrest with extension tubes

1. Loosen the Allen Screws in the two binder clamps that secure the footrest extension to the frame. See Figures 9 and 10. If replacing the footrest, loosen the Allen Screws sufficiently to permit you to completely remove both footrest extensions. If adjusting the height of the footrest, loosen the Allen Screws sufficiently to permit the footrest extensions to move up and down freely within the binder clamps. You can also raise or lower the position of the clamp on the frame to achieve a greater range of adjustability.
2. *This Step 2 applies to the Evo and the TR with "C" package only. For all other chairs, skip to Step 3 below.* If you need to raise or lower the position of the binder clamp on the frame in order to achieve the necessary range of adjustability, you will need to increase or lessen the width of the tube onto which the footrest is clamped. To do this, loosen the Allen Screws that secure the footplate to the footplate clamp as though you were going to adjust the angle of the footrest. See also Figure 7. When this clamp is loosened, you can adjust the width of the horizontal tubes inside the footplate clamp.
3. Place the end of a ruler on the floor and hold it vertically against the left corner of the footrest. See Figure 3. Adjust the left side of the footrest (or the new footrest) to the desired height (not less than 2" of ground clearance) and tighten the Allen Screw in the left binder clamp so the left side of the footrest cannot change.
4. Repeat the procedure from step 3 above on the right side of the footrest (or the new footrest).
5. If you loosened the Allen Screws described in Step 2 above, securely tighten them.
6. When both sides are set at an equal distance from the floor, make sure all four wheels are in contact with the floor and then fully tighten the two Allen Screws in the binder clamps that secure the footrest extensions to the chair frame.

Note Regarding High Mount Footrests: The Angle Adjustable High Mount Footrests on the TR Series, YR Series and the Evo may be clamped with the tubes in a downward position (see Figure 9), or they may be attached in an upward position (see Figure 10) in order to increase the range of adjustability. This adjustment is not possible with the Evo or the TR with "C" package if your chair has a tapered frame.

Angle Adjustable High Mount Footrest

(ZR Series and Aero Z)

Adjusting the Angle of the Footrest

Tools needed:

- 5/32" Allen Wrench
- 7/16" Open End Wrench (no extension tubes)
- 3/16" Allen Wrench (extension tubes only)

1. Loosen, but do not remove, the Allen Screws. See Figure 11. If your footrest has extension tubes (see Figure 12), you will have 3/16" Allen Screws in place of lock nuts and you will only need to loosen these latter Allen Screws to adjust the angle.
2. Adjust the footrest to the desired angle.
3. Tighten the Allen Screws and locknuts (or 3/16" Allen Screws), making sure the screws and the locknuts (or 3/16" Allen Screws) are secure and will not permit the footplate to move up or down under your weight.

Replacing or Adjusting the Height of the Footrest

The Angle Adjustable High Mount Footrest for the ZR Series wheelchairs can be replaced or the height adjusted by using the tools and following the procedures under "Titanium Footrest with Flat ABS Cover (ZR Series)" on pages 26-27.

The Angle Adjustable High Mount Footrest for the Aero Z wheelchair can be replaced or the height adjusted by using the tools and following the procedures under "Titanium Footrest with Flat ABS Cover (Aero Z)" on page 27.

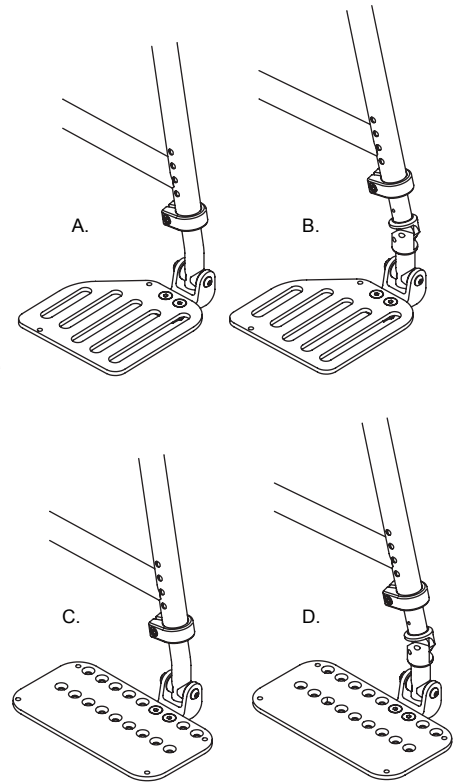

Figure 13

YG Flip-Up Footrests

- A. Flip-Up
- B. Angle Adjustable Flip-Up
- C. Depth Adjustable Flip-Up
- D. Depth & Angle Adjustable Flip-Up

1-Piece Angle Adjustable Rigid (High Mount) Footrests

(YG)

The angle of the 1-Piece Angle Adjustable Rigid Footrest (see Figure 8) and of the 1-Piece Angle Adjustable Rigid High Mount Footrest (see Figures 9 and 10), can be adjusted by using the tools and following the procedures under "Angle Adjustable Footrest (TR Series, YR Series, ZR Series, Aero Z, BB and Evo)" on page 28.

The 1-Piece Angle Adjustable Rigid Footrest (see Figure 8) can be replaced or the height adjusted by using the tools and following the procedures under "Titanium Footrest with Flat ABS Cover (TR, YR, and BB)" on page 25.

The 1-Piece Angle Adjustable High Mount Footrest (see Figures 9 and 10) can be replaced or the height adjusted by using the tools and following the procedures under "Angle Adjustable High Mount Footrest (TR Series, YR Series and Evo)" on pages 28-29.

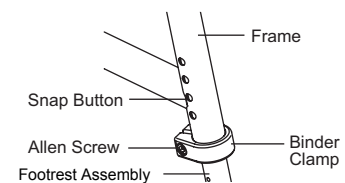

Figure 14

Adjusting/Replacing YG Series Flip-Up Footrests

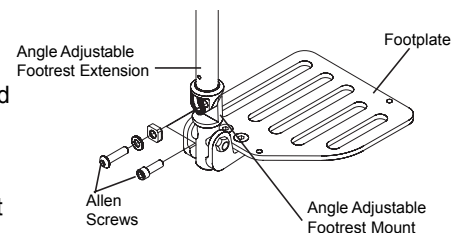

Figure 15

Angle Adjustable Flip Up Footrest Extension

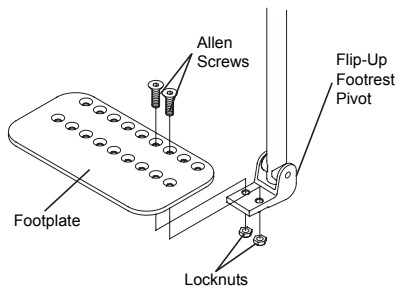

Figure 16
Depth Adjustments on YG Series Flip-Up Footrests

Flip-Up Footrest; Angle Adjustable Flip-Up Footrest; Depth Adjustable Flip-Up Footrest; and Depth and Angle Adjustable Flip-Up Footrest (YG Series)

If you are unsure which type of flip-up footrest is installed on your YG Series chair, see Figure 13.

Note: If your YGS chair has 90° hangers (see Figure 19), see “90° Hanger Flip-Up Footrests; 90° Hanger Depth Adjustable Flip-Up Footrests” on page 33 or “90° Hanger Depth and Angle Adjustable Flip-Up Footrests” on pages 33-34.

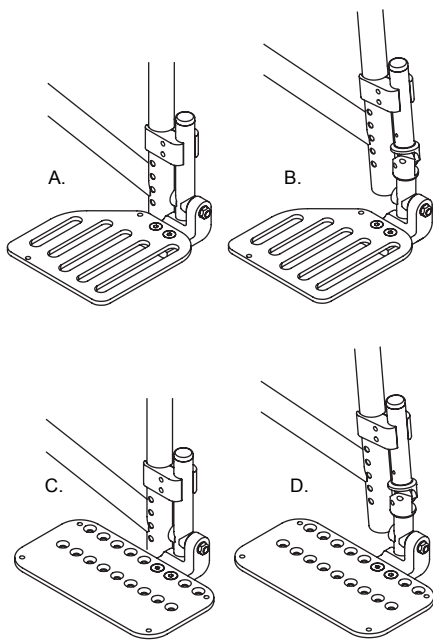

Figure 17
YG High Mount Flip-Up Footrests
A. High Mount Flip-Up
B. Angle Adjustable High Mount Flip-Up
C. Depth Adjustable High Mount Flip-Up
D. Depth & Angle Adjustable High Mount Flip-Up

Replacing or Adjusting the Height of the Footrest

Tools Needed:

- 3/16" Allen Wrench

1. Loosen the Allen Screw on the binder clamp. See Figure 14.
2. Depress the snap button and raise or lower the footrest assembly to the desired height (not less than 2" of ground clearance), making sure the snap button pops out through a hole in the frame.
3. If replacing the complete footrest assembly, remove the footrest assembly completely and reinsert a new footrest assembly, making sure the snap button pops out through a hole in the frame.
4. Securely tighten the Allen Screw on the binder clamp.

Adjusting the Angle of the Footrest

Tools Needed:

- 3/16" Allen Wrench
- 5/32" Allen Wrench

If your flip-up footrest is angle adjustable, you can adjust the angle as follows:

1. Loosen the two Allen Screws that clamp the angle adjustable footrest extension to the angle adjustable footrest mount. See Figure 15.
2. Adjust the angle of the footrest to the desired angle.
3. Securely tighten the two Allen Screws that clamp the angle adjustable footrest extension to the angle adjustable footrest mount, making sure the teeth on the locking block are properly engaged to prevent the footrest from moving.

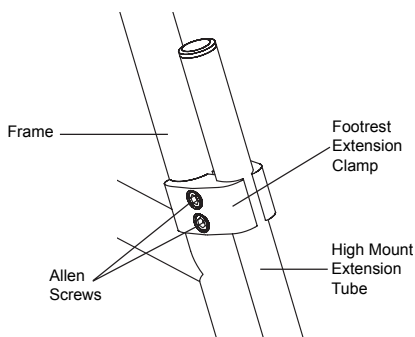

Figure 18
Height Adjustments on YG Series High Mount Flip-Up Footrests

WARNING

The threads on the Allen Screws that secure the angle adjustable footrest extension to the angle adjustable footrest mount have been treated with a medium strength threadlock to reduce the possibility they will become loose. You should be able to adjust the angle of

the footrest two or three times without reapplying threadlock to these screws. If you repeatedly adjust the angle, TiLite requires that you reapply a medium strength threadlock after every second adjustment.

Adjusting the Depth of the Footrest

Tools Needed:

- 5/32" Allen Wrench
- 7/16" End Wrench

If your flip-up footrest is depth adjustable, you can adjust the depth as follows:

1. Remove the flat head Allen Screws and locknuts that attach the footplate to the flip-up footrest pivot. See Figure 16.
2. Move the footplate forward or backward to the desired depth setting.
3. Reinstall and securely tighten the Allen Screws and locknuts

High Mount Flip-Up Footrest; Angle Adjustable High Mount Flip-Up Footrest; Depth Adjustable High Mount Flip-Up Footrest; and Depth and Angle Adjustable High Mount Flip-Up Footrest (YG Series)

If you are unsure which type of High Mount Flip-Up Footrest is installed on your YG Series chair, see Figure 17. **Note:** If your YGS chair has 90° hangers (see Figure 19), see "90° Hanger Flip-Up Footrests; 90° Hanger Depth Adjustable Flip-Up Footrests" on page 33 or "90° Hanger Depth and Angle Adjustable Flip-Up Footrests" on pages 33-34.

Replacing or Adjusting the Height of the Footrest

Tools Needed:

- 3/16" Allen Wrench

1. Loosen the two Allen Screws through the footrest extension clamp that secures the high mount footrest extension tube to the frame. See Figure 18.
2. Raise or lower the high mount footrest extension tube to the desired height (not less than 2" of ground clearance).
3. If replacing the entire footrest assembly, remove the high mount footrest extension tube and flip-up footrest assembly completely and reattach a new high mount footrest extension tube and footrest assembly at the desired height (not less than 2" of ground clearance).
4. When both of the footrests on both sides of the chair are adjusted to the desired height, securely tighten the two Allen Screws through the extension clamp that secures the high mount footrest extension tube to the frame.

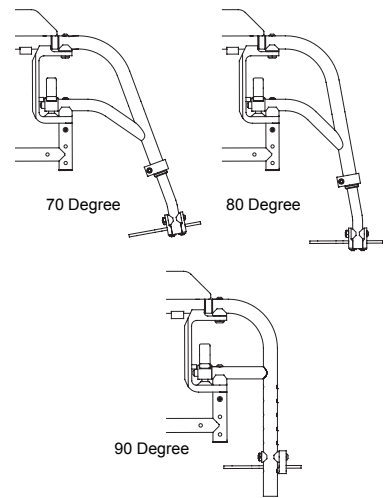

Figure 19
Available Hanger Options

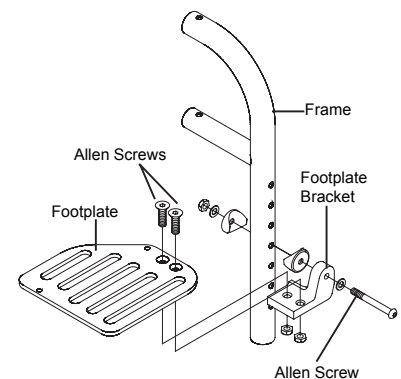

Figure 20
YGS 90° Hanger Flip-Up Footrest

Adjusting the Angle or Depth of the Footrest

If your high mount flip-up footrest is angle or depth adjustable or both, you can adjust the angle or depth by using the tools and following the procedures for adjusting the angle or depth of a flip-up footrest as set forth under “Flip-Up Footrest; Angle Adjustable Flip-Up Footrest; Depth Adjustable Flip-Up Footrest; and Depth and Angle Adjustable Flip-Up Footrest” on pages 31-32.

90° Hanger Flip-Up Footrests; 90° Hanger Depth Adjustable Flip-Up Footrests (YGS)

Replacing, or Adjusting the Height of, the Flip-Up or Depth Adjustable Flip-Up Footrest

Tools Needed:

- 5/32" Allen Wrench
- 7/16" Open End Wrench

1. Remove the Allen Screw that secures the footplate bracket to the frame. See Figures 20 or 21. Make sure to note the order in which you remove the various washers and nuts when removing the Allen Screw.
2. Reposition the existing (or replacement) footrest assembly to the desired height (not less than 2" of ground clearance), lining up the hole in the footplate bracket with a hole in the frame.
3. Reinsert the Allen Screw through the 1/2" washer, footplate bracket, the 1" concave washer, the frame, the second 1" concave washer, the second 1/2" washer and the lock nut. Securely tighten.

Adjusting the Depth of the Footrest

Tools Needed:

- 5/32" Allen Wrench
- 7/16" Open End Wrench

1. Remove the two Allen Screws and locknuts that secure the footplate to the angle adjustable footrest bracket. See Figure 21.
2. Reposition the footplate to the desired depth.
3. Reinsert and securely tighten the two Allen Screws and locknuts .

90° Hanger Depth and Angle Adjustable Flip-Up Footrests (YGS)

Replacing, or Adjusting the Height of, the Footrest

Tools Needed:

- 5/32" Allen Wrench
- 7/16" Open End Wrench

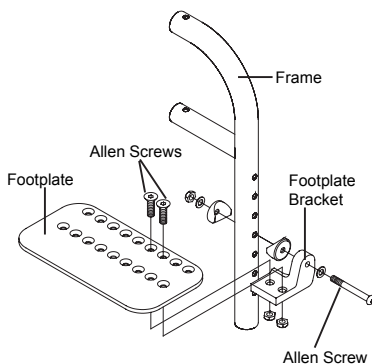

Figure 21
YGS 90° Hanger Depth Adjustable Flip-Up Footrest

1. Remove the Allen Screw that secures the angle adjustable footrest bracket to the frame. See Figure 22. Make sure to note the order in which you remove the various washers and nuts when removing the Allen Screw.
2. Reposition the existing (or replacement) footrest assembly to the desired height (not less than 2" of ground clearance), lining up the holes in the angle adjustable footrest bracket with the holes in the frame.
3. Reinsert the Allen Screw through the 1/2" washer, the angle adjustable footrest bracket, the concave washer, the frame, the second concave washer, the angle adjustable footrest bracket, the second 1/2" washer and the lock nut. Securely tighten.

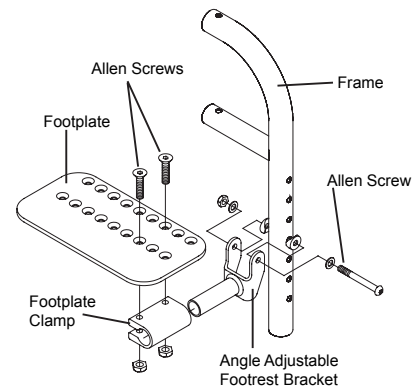

Figure 22
YGS 90° Hanger Depth and Angle Adjustable Flip-Up Footrest

Adjusting the Angle of the Footrest

Tools Needed:

- 5/32" Allen Wrench
- 7/16" Open End Wrench

1. Loosen the two Allen Screws and locknuts that secure the footplate to the footplate clamp. See Figure 22.
2. Reposition the footplate to the desired angle.
3. Securely tighten the two Allen Screws and locknuts.

Adjusting the Depth of the Footrest

Tools Needed:

- 5/32" Allen Wrench
- 7/16" Open End Wrench

1. Remove the two Allen Screws and locknuts that secure the footplate to the footplate clamp. See Figure 22.
2. Reposition the footplate to the desired depth.
3. Reinsert the two Allen Screws through the footplate, the footplate clamp and the locknuts.
4. Securely tighten the two Allen Screws and locknuts.

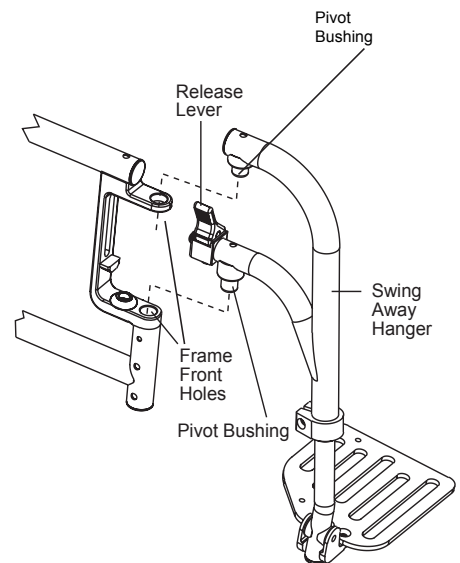

Figure 23
YGS Swing-Away Hangers

Swing-Away Hangers

(YGS)

The swing-away hangers can be rotated inward or outward to be removed or positioned out of the way.

To swing the hanger inward or outward, push or pull the release lever and push the hanger inward or outward, as desired.

To remove the hanger from the wheelchair, swing it outward and pull it upward.

To replace the hanger on frame:

1. Align the pivot bushings with the frame front holes, sliding in the bottom pivot first. This must be done with the hanger slightly off center of the frame. See Figure 23.
2. Holding the hanger (not the release lever), swing the hanger until hanger locks in place.

CHAPTER 4: BACKRESTS, PUSH HANDLES AND STROLLER HANDLES

Adjustable Height & Angle Backrest (Titanium or Aluminum)

(TR Series, YR Series, YG Series, ZR Series, Aero Z and Evo)

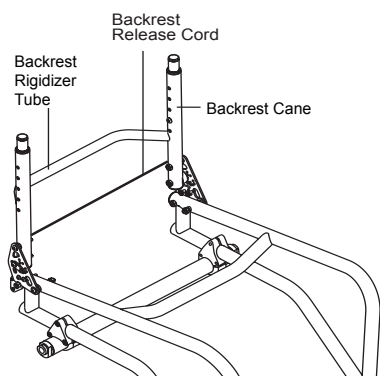

Figure 24
Adjustable Backrest with Backrest Release Cord

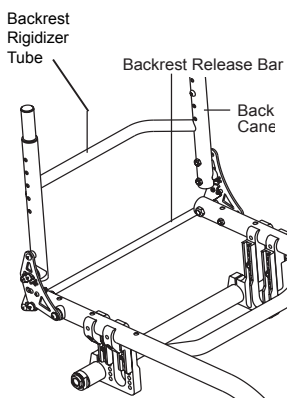

Figure 25
Adjustable Height & Angle Backrest with Backrest Release Bar

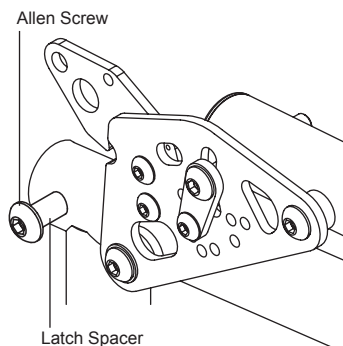

Figure 26
Adjusting the Backrest Lock Bracket

NOTE: The aluminum Adjustable Height and Angle Backrest without integrated push handles is standard on all wheelchairs listed. The titanium Adjustable Height and Angle Backrest, is available as an option on all chairs except the YG Series. Integrated push handles are available as an option with either the titanium or aluminum backrest. The instructions in this section apply to all of these variations.

WARNING

Before using your wheelchair, make sure the Adjustable Height & Angle Backrest is locked securely in place in the upright position and all mounting hardware is securely tightened. *If you ignore this Warning, you may fall, tip over or lose control of the wheelchair and seriously injure yourself or others or damage the wheelchair.*

Folding the Backrest

1. Grasp the backrest release cord (see Figure 24) or backrest release bar (see Figure 25) and pull up.
2. Push the back canes or backrest rigidizer tube forward toward the front of the chair.

Unfolding the Backrest

1. Lift up on the back canes or backrest rigidizer tube and pull towards the rear of the chair.
2. Make sure back locks securely into place.

Adjusting the Backrest Lock Bracket

Tools Needed:

- 5/32" Allen Wrench
- 7/16" Open End Wrench

If the backrest will not lock in the unfolded (upright) position, follow these procedures:

1. Fold the backrest down over the seat.
2. Loosen, but do not remove, the Allen Screw. See Figure 26.
3. Rotate the latch spacer.
4. Securely tighten the Allen Screw.
5. If the backrest still will not lock securely in the unfolded position, repeat the procedure on the opposite side of the chair.

Adjusting if there is “Play” in the Backrest or Backrest Bracket

Tools Needed:

- 7/16" End Wrench
- 5/32" Allen Wrench
- 1/8" Allen Wrench
- 3/8" Open End Wrench

If the backrest or backrest bracket becomes loose or there is “play” in the folding backrest assembly, follow these procedures:

1. On both sides of the chair, tighten both Allen Screws shown in Figure 27.
2. Repeat this procedure until there is no “play” in the folding backrest assembly.
3. Do not overtighten the “pivot” screw or the backrest will not fold/unfold.

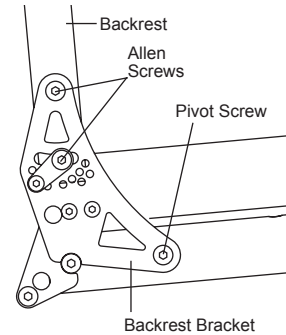

Figure 27
Adjusting for “play” in the Backrest Bracket

Changing the Backrest Angle

Tools Needed:

- 7/16" End Wrench
- 5/32" Allen Wrench
- 1/8" Allen Wrench

1. Lock the backrest in the unfolded position.
2. On both sides of the chair, loosen, but do not remove, the two Allen Screws that attach the backrest to the backrest bracket. See Figure 28.
3. On both sides of the chair, completely remove the link screw that attaches the link to the backrest bracket.
4. Keeping the backrest bracket locked in the unfolded position, tilt the backrest forward or backward to the desired angle.
5. On one side of the chair, line up the hole in the link with the closest available threaded hole in the backrest bracket. It may be necessary to make a minor adjustment to the backrest angle in order to properly align the hole in the link with an available threaded hole in the backrest bracket. Once aligned, reinsert and fully tighten the link screw removed in step 3 to securely attach the link to the backrest assembly.
6. On the opposite side of the chair, attach the link to the backrest bracket using the corresponding threaded hole in the backrest bracket using the link screw removed in step 3.
7. On both sides of the chair, securely tighten the Allen Screws that were loosened in step 2.

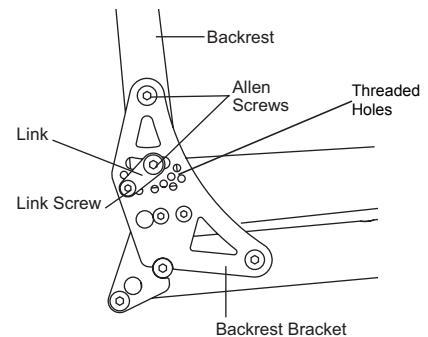

Figure 28
Adjusting the Backrest Angle

Adjusting the Backrest Height

Tools Needed:

- 5/32" Allen Wrench

Note: In order to adjust the backrest height you will have to remove the backrest upholstery. Therefore, make a note of the tautness of the backrest upholstery before removing it so you can reinstall it to approximately the same degree of tautness.

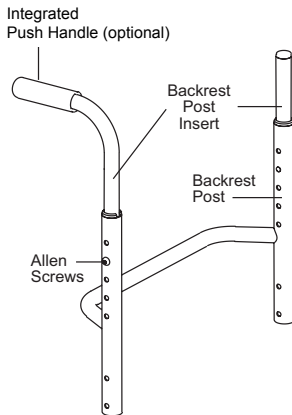

Figure 29
Adjusting the Backrest Height

1. Remove the backrest upholstery, including the two fastening flaps. See “Velcro Adjustable Back Upholstery” or “Tension Adjustable by Straps Back Upholstery” on pages 49-51.
2. On both sides of the chair, remove the Allen Screw that secures the backrest post inserts inside the backrest post. See Figure 29.
3. Reposition both backrest post inserts to the desired height inside the backrest posts, making sure to align the holes in the backrest post inserts with the holes in the backrest posts.
4. Make sure both backrest post inserts are at the same height in the backrest posts and reinsert and securely tighten the two Allen Screws.
5. Reinstall the back upholstery, including the two fastening flaps, and adjust the upholstery to the desired tautness. See “Velcro Adjustable Back Upholstery” or “Tension Adjustable by Straps Back Upholstery” on pages 49-51.

WARNING

The threads on the Allen Screws that secure the backrest posts to the backrest post inserts have been treated with a medium strength threadlock to reduce the possibility that they will become loose. You should be able to adjust the backrest height two or three times without reapplying threadlock to these screws. If you repeatedly adjust the backrest height, TiLite requires that you reapply a medium strength threadlock after every second adjustment.

Non-Folding Titanium Adjustable Height Backrest

(BB)

If your chair has a non-folding Titanium Adjustable Height Backrest, you can adjust the backrest height by using the tools and following the procedures for adjusting the backrest height under “Adjustable Height & Angle Backrest (Titanium or Aluminum)” on pages 35-37.

Non-Folding Fixed Height & Angle Backrest

(TR, YR and BB)

If your chair has a non-folding Titanium Fixed Height & Angle Backrest, you cannot adjust the backrest height or the backrest angle.

Stroller Handles (TRA, YRA)

The stroller handles operate using stroller handle receivers that operate similarly to the swing away armrest receivers on the TRA and YRA wheelchairs. Figures 30 and 31 show examples of the stroller handles being used with and without swing away armrests.

To adjust the height of the stroller handles, follow the procedures under “Adjusting the Height of the Armrest Receiver (TRA and YRA)” on page 42.

To adjust the height of the stroller handle receiver, follow the procedures under “Adjusting the Height of the Armrest Receiver (TRA and YRA)” on page 42.

The stroller handle is equipped with a quick release pin to prevent the stroller handle from coming out while in use and for easy removal. To remove the stroller handles push the release button on the release pin and slide it out. The release pin is attached with a lanyard to prevent it from being lost.

Stroller Handles (YG Series)

The stroller handles operate using stroller handle receivers that operate similarly to the swing away armrest receivers on the TRA, YRA and EVO wheelchairs. Figure 32 shows the YG Series stroller handle receiver.

Adjusting the Height of the Receiver

Tools Needed:

- 5/32" Allen Wrench
- 7/16" Open End Wrench

1. Remove the Allen Screws that secure the stroller handle receiver to the frame. See Figure 32.
2. Reposition the stroller handle receiver to the desired height and reinsert the Allen Screws through the complete assembly. Securely tighten the Allen Screws and lock nuts.

WARNING

When reassembling, make sure that at least one of the Allen Screws bolts the axle plate to the frame. This may limit your options for adjusting the height of the stroller handle receiver.

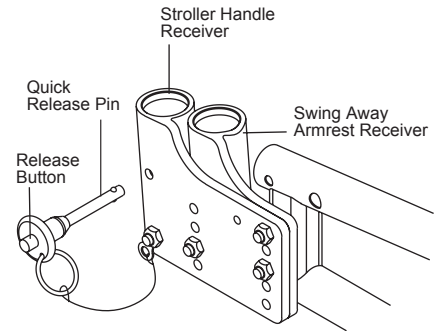

Figure 30
Armrest and Stroller Handle Assembly

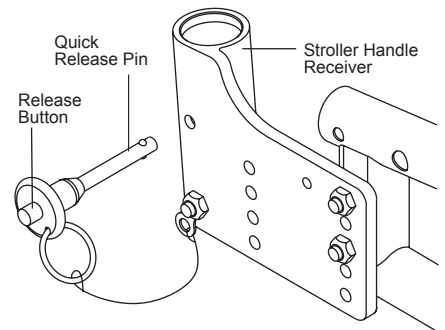

Figure 31
Stroller Handle Assembly without Armrests

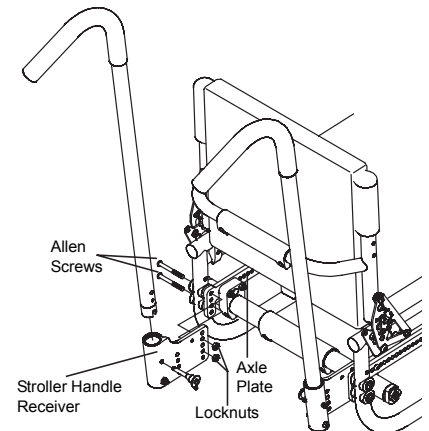

Figure 32
YG Series Stroller Handle Assembly



Figure 33
Proper Location for Clamp-On Push Handles

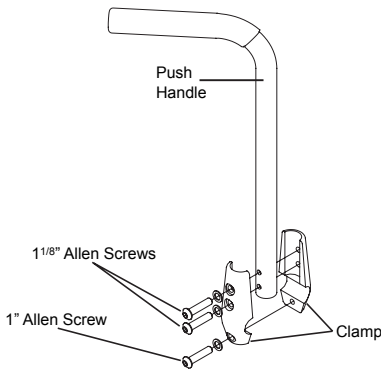

Figure 34
Clamp-On Push Handles

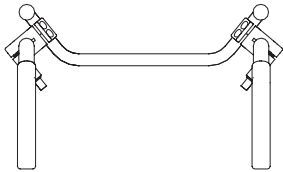

Figure 35
Proper Location for Height Adjustable Clamp-On Push Handles

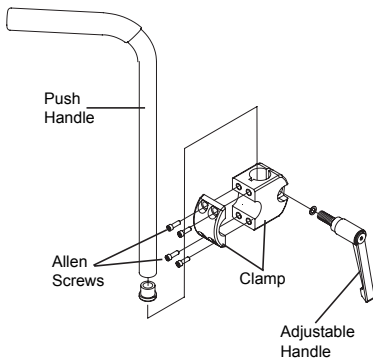

Figure 36
Height Adjustable Clamp-On Push Handles

Bolt-On Push Handles

(TR Series, YR Series, ZR Series, Aero Z and Evo)

Mounting Push Handles:

Tools Needed:

- 5/16" Allen Wrench

1. See Figure 33 for the correct location to mount the clamp-on push handles to the rigidizer bar.
2. Assemble the two halves of the clamp around the rigidizer bar. See Figure 34.
3. Insert the 1" Allen Screw through a washer into the bottom hole on the clamp and loosely tighten.
4. Insert the push handle into the clamp and align the holes in the push handle with the upper two holes in the clamp.
5. Insert the two 1-1/8" Allen Screws through the washers, the two halves of the clamp and the push handles and securely tighten.
6. Make sure the push handle is correctly positioned for proper pushing and securely tighten the 1" Allen Screw.

⚠ WARNING

NEVER attempt to lift a wheelchair up a curb, step or flight of stairs by lifting on any removable (detachable) parts, such as clamp-on push handles. *If you ignore this Warning, you may fall, tip over or lose control of the wheelchair and seriously injure yourself or others or damage the wheelchair.*

Removing Push Handles:

Tools Needed:

- 5/16" Allen Wrench

1. Remove the three Allen Screws and remove the clamp and handle. See Figure 34.

Adjustable Height Bolt-On Push Handles

(TR Series, YR Series, ZR Series, Aero Z and Evo)

Mounting Push Handles:

Tools Needed:

- 3/8" Allen Wrench

1. See Figure 35 for the correct location to mount the height adjustable clamp-on push handles.
2. Assemble the two halves of the clamp around the rigidizer bar. See Figure 36.
3. Insert the 4 Allen Screws into the two halves of the clamp and loosely tighten.
4. Insert the push handle through the clamp until the handle is at the desired height and loosely tighten the adjustable handle.

5. Securely tighten the four Allen Screws.
6. Engage the adjustable handle by pressing it toward the clamp. This will securely hold the push handle. Check for any looseness and, if necessary, disengage adjustable handle, screw it in further and re-engage it.

 WARNING

NEVER attempt to lift a wheelchair up a curb, step or flight of stairs by lifting on any removable (detachable) parts, such as height adjustable clamp-on push handles. *If you ignore this Warning, you may fall, tip over or lose control of the wheelchair and seriously injure yourself or others or damage the wheelchair.*

Removing Push Handles:

Tools Needed:

- 3/8" Allen Wrench

1. Remove the four Allen Screws and remove the clamp and handle.

CHAPTER 5: ARMRESTS

Tubular Swing Away Armrest (TR Series, YR Series, ZR Series, Aero Z and Evo)

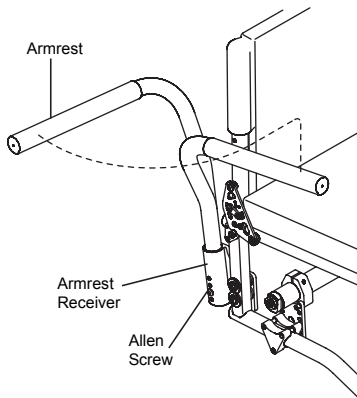

Figure 37
TRA/YRA /Evo Tubular Swing Away Armrest

To swing away the armrest, lift the armrest and rotate the armrest away from chair. See Figures 37 and 38. On the TR, YR, ZR Series and Aero Z, make sure to lift the armrest until the armrest pins are above the notch on the armrest receiver. See Figure 38.

To replace the armrest, rotate the armrest back towards the chair and gently push it down into place. See Figures 37 and 38. On the TR, YR, ZR Series and Aero Z, make sure the armrest pins are in the notch on the armrest receiver. See Figure 38.

NOTE: On all TiLite rigid wheelchairs, the swing away armrests pivot on nylon sleeves, located inside the armrest receiver. If the armrest does not rotate properly, check the nylon sleeves for wear.

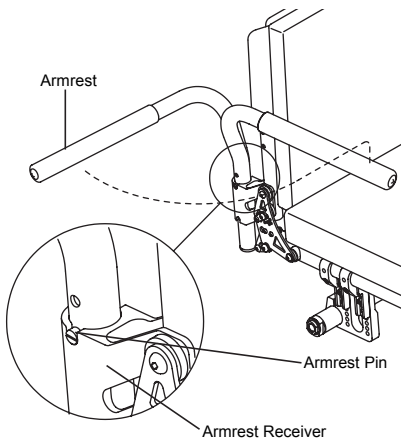

Figure 38
ZR Series/Aero Z/TR/YR Tubular Swing Away
Armrest

Adjusting the Height of the Tubular Swing Away Armrest (ZR Series, Aero Z, TR and YR)

Tools Needed:
• 2 Flat Head Screwdrivers

1. Remove the armrest from the armrest receiver.
2. Remove both armrest pins. See Figure 39.
3. Reassemble the armrest pins in the desired location on the armrest (in 3/4" increments).
4. Securely tighten both armrest pins in the new location.
5. Reinstall the armrest in the armrest receiver.

Adjusting the Height of the Tubular Swing Away Armrest (TRA, YRA and Evo)

Tools Needed:
• 5/16" Allen Wrench
• 7/16" Open End Wrench

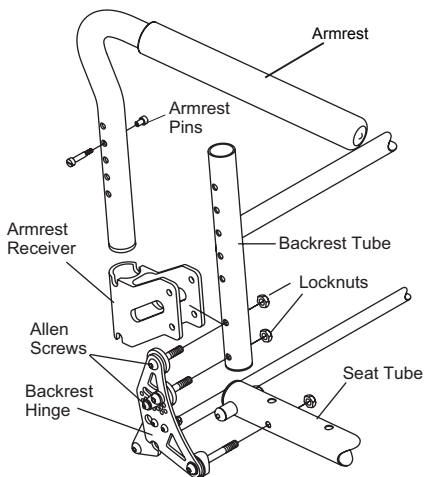

Figure 39
Height Adjustment of ZR Series/Aero Z/TR/YR
Tubular Swing Away Armrest Receiver

1. Remove the armrest from the armrest receiver.
2. Remove the Allen Screw that passes through the armrest receiver. See Figure 40.
3. Reinsert the Allen Screw through the armrest receiver at the desired location (in 1/2" increments).
4. Securely tighten the Allen Screw in the new location.
5. Reinstall the armrest in the armrest receiver.

Adjusting the Height of the Armrest Receiver (ZR Series, Aero Z, TR and YR)

Tools Needed:

- 5/32" Allen Wrench
- 7/16" End Wrench

The armrest receiver can be inverted to achieve a higher or lower height range for the swing away armrest. See Figure 41.

1. Remove the armrest from the armrest receiver.
2. Remove the two Allen Screws that pass through the backrest hinge, the armrest receiver and the backrest tube. See Figure 39. Do not remove the Allen Screws that attach the backrest hinge to the seat tube.
3. Remove and invert the armrest receiver and slide it back into place between the backrest tube and the backrest hinge, making sure to align the holes in the backrest receiver with the holes in the backrest tube and the backrest hinge.
4. Reinsert the Allen Screws through the reassembled backrest hinge, the inverted armrest receiver and the backrest tube and securely tighten the Allen Screws and locknuts.
5. Reinstall the armrest in the armrest receiver.

Adjusting the Height of the Armrest Receiver (TRA and YRA)

Tools Needed:

- 5/32" Allen Wrench
- 7/16" Open End Wrench

The armrest receiver can be raised or lowered to achieve a higher or lower height range for the swing away armrest.

1. Remove the armrest from the armrest receiver.
2. Remove the two Allen Screws and locknuts that secure the armrest receiver to the frame. See Figure 40.
3. Reposition the armrest receiver to the desired height and reinsert the Allen Screws through the frame. Securely tighten the locknuts and Allen Screws.
4. Reinstall the armrest in the armrest receiver.

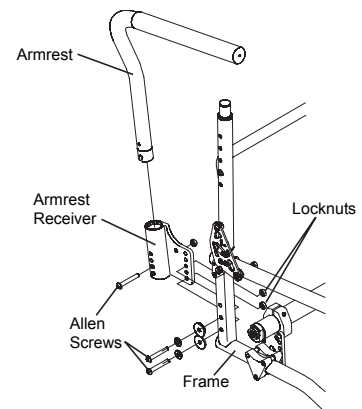

Figure 40
Height Adjustment of TRA/YRA Tubular Swing
Away Armrest

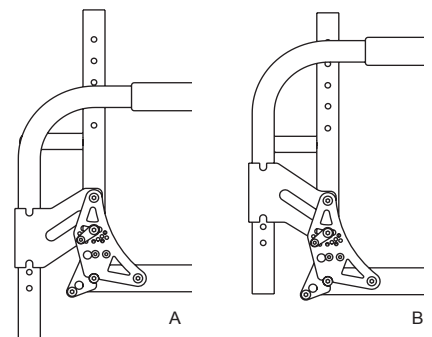

Figure 41
ZR Series/Aero Z/TR/YR Armrest Height
A. 9" - 12" B. 11" - 14"

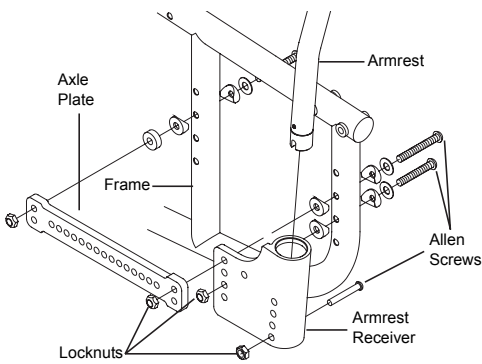

Figure 42
Height Adjustment of EVO Tubular Swing Away
Armrest Receiver

Adjusting the Height on the Armrest Receiver (Evo)

Tools Needed:

- 5/32" Allen Wrench
- 7/16" Open End Wrench

The armrest receiver can be raised or lowered to achieve a higher or lower height range for the swing away armrest.

1. Remove the armrest from the armrest receiver.
2. Remove the two Allen Screws that pass through the frame, the armrest receiver, the axle plate, and the various washers and locknuts. See Figure 42.
3. Reposition the armrest receiver to the desired height and reinsert the Allen Screws through the complete assembly. Securely tighten the Allen Screws and locknuts.
4. Reinstall the armrest in the armrest receiver.

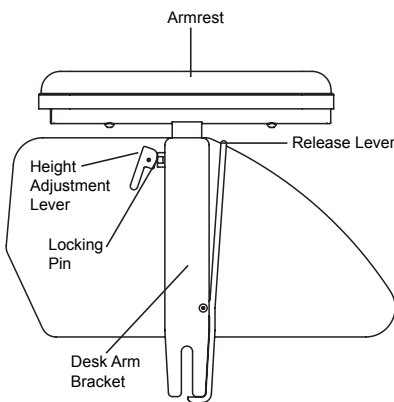

Figure 43
Removable Desk Arm

⚠ WARNING

When reassembling, make sure that one of the Allen Screws bolts the axle plate to the frame. This may limit your options for adjusting the height of the armrest receiver.

Removable Desk Arm and Removable Desk Arm with Transfer Loop

(TR Series, YR Series and Evo)

⚠ WARNING

Make sure the locking pin activated by the height adjustment lever is securely positioned in the desk arm bracket before applying weight to the armrest.

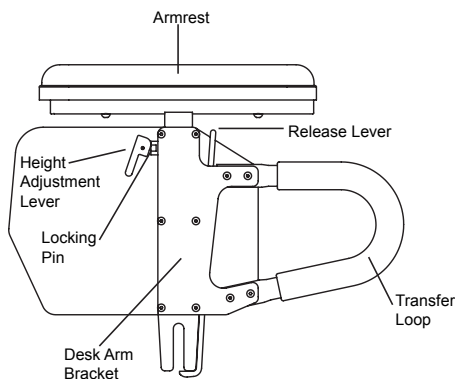

Figure 44
Removable Desk Arm with Transfer Loop

Adjusting the Armrest Height

1. Pull up on the height adjustment lever to permit the armrest to be raised or lowered to the desired height. See Figures 43 and 44.
2. After repositioning the armrest to the desired height, release the height adjustment lever to lock the armrest in that position. The positioning holes are in 1/2" increments. The height ranges from 9" to 12" or 12" to 15" depending on the size of desk arm ordered.

Removing

1. To remove the desk arm assembly, press and hold the armrest release lever. See Figures 43 and 44.
2. While holding the armrest release lever, lift the desk arm assembly to remove it from the mounting bracket attached to the wheelchair frame. See Figure 45.

Replacing

Slide the desk arm bracket into the mounting bracket attached to the wheelchair frame. See Figure 45.

WARNING

Make sure the desk arm bracket securely locks in the mounting bracket before applying weight to the desk arm.

Swing Away - Flip Back Armrest (YG Series)

Using the Swing Away - Flip Back Armrest
To flip back the armrest, raise the front of the armrest and rotate it straight back as far as possible. Reverse this procedure to return the armrest to its original position. See Figure 46.

To swing away the armrest, lightly lift up on the armrest and rotate the armrest away from the chair. See Figure 46. To replace the armrest, swing it back towards the chair and gently push it back down into place.

Note: The swing away armrests pivot on nylon sleeves located inside the armrest receptacle. If the armrest does not rotate properly, check the sleeves for wear.

Adjusting Armrest Height

Tools Needed:

- 2 Flat Head Screwdrivers

1. Remove both armrest pins from the armrest upright. See Figure 47.
2. Reassemble the armrest pins in the desired location on the armrest upright (in 1/2" increments).
3. Securely tighten both armrest pins in the new location.

WARNING

The threads on the armrest pins in the armrest uprights have been treated with a medium strength threadlock to reduce the possibility that they will become loose. You should be able to adjust the height of the Swing Away - Flip Back Armrest two or three times without reapplying threadlock to these screws. If you repeatedly adjust the armrest height, TiLite requires that you reapply medium strength threadlock after every second adjustment.

Adjusting Armrest Angle

Tools Needed:

- 5/32" Allen Wrench

1. To adjust the angle at which the armrest sits when in the down position, loosen, but do not remove, the Allen Screw that secures the armrest stop clamp. See Figure 48.

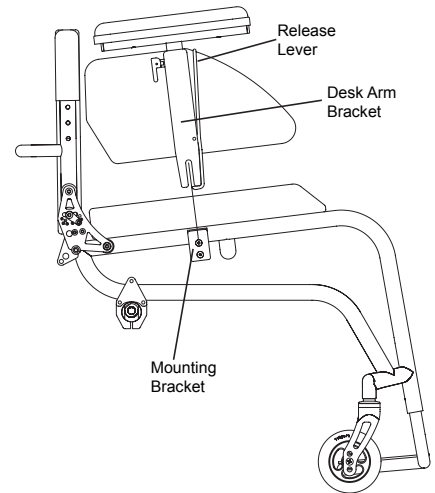

Figure 45
Replacing the Mounting Bracket

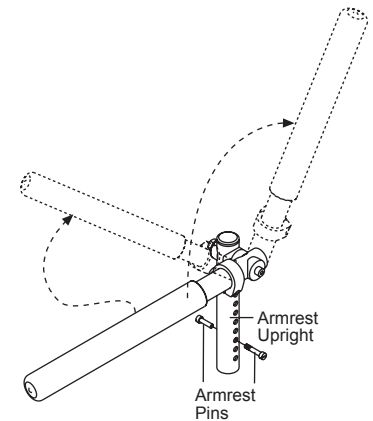

Figure 46
Using the Swing Away Flip Back

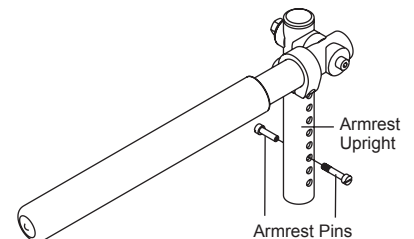

Figure 47
YG Series Armrest Height Adjustment

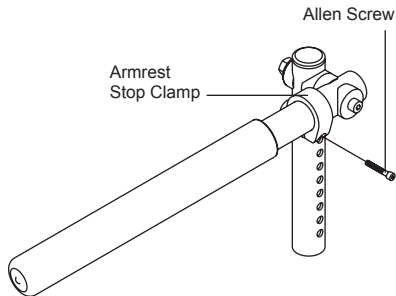

Figure 48
YG Series Armrest Angle Adjustment

2. Slide the armrest stop clamp forward on the armrest to lower the angle at which the armrest sits in the down position, or slide the armrest stop clamp backward on the armrest to raise the angle.
3. Securely tighten the Allen Screw to fix the armrest stop clamp in place.

⚠ WARNING

Make sure that the armrest stop clamp is securely tightened before applying weight to the armrest.

Locking the Armrest in Place

Tools Needed:

- 3/16" Allen Screw
- 7/16" End Wrench

1. To lock the armrest in place after the armrest is seated in the armrest receiver in the desired position, insert the locking screw through the armrest receiver and the armrest. See Figure 49.
2. Securely tighten the locknut to the locking screw.

Note: TiLite YG Series wheelchairs do not ship with locking screws and nuts. If you require the locking screws and nuts, please contact TiLite Customer Service at 1-800-545-2266.

Note: Locking the armrest in place only prevents the armrest from swinging away. The armrest will still flip back.

Note: Depending on the configuration of your chair (including rear wheel height and armrest height) it may not be possible to lock the armrest in place.

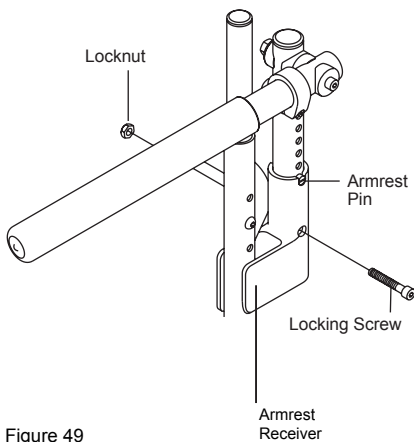

Figure 49
Locking the Armrest in Place

CHAPTER 6: SIDE GUARDS

Cloth Side Guards

(TR Series, YG Series, YR Series, ZR Series, Aero Z, BB and Evo)

Removing/Replacing Cloth Side Guards

1. Lift up on the seat cushion and remove it from the chair.
2. Separate the cloth side guards from the seat upholstery and the back upholstery. See Figure 50.
3. If desired, install new cloth side guards onto the seat and back upholstery. **Note:** The fastening flaps that secure the cloth side guards to the back upholstery wrap around the outside of the back canes and under the back upholstery flap.
4. Replace the seat cushion.

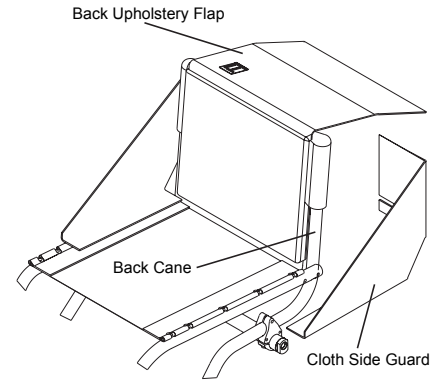

Figure 50
Cloth Side Guard Removal and Replacement

Rigid Removable and Quad Removable Side Guards

(Standard and Carbon Fiber)

(TR Series, YR Series, ZR Series, Aero Z, BB and Evo)

Using Rigid Side Guards

To remove either type of rigid side guard, lift the side guard out of the side guard mount by grasping it at the top or place finger in the hole and pull it upward. To replace, place the side guard bracket into the slot between the side guard mount and the side guard clamp and push down. See Figure 51.

Adjusting Rigid Side Guards

Tools Needed:

- 1/8" Allen Wrench

You can adjust the “snugness” of the fit of the side guard bracket in the side guard mount by loosening or tightening the two Allen Screws in the side guard mount. See Figure 51.

Either type of rigid side guard can be made “non-removable” by firmly tightening the two Allen Screws in the side guard mount while the side guard is

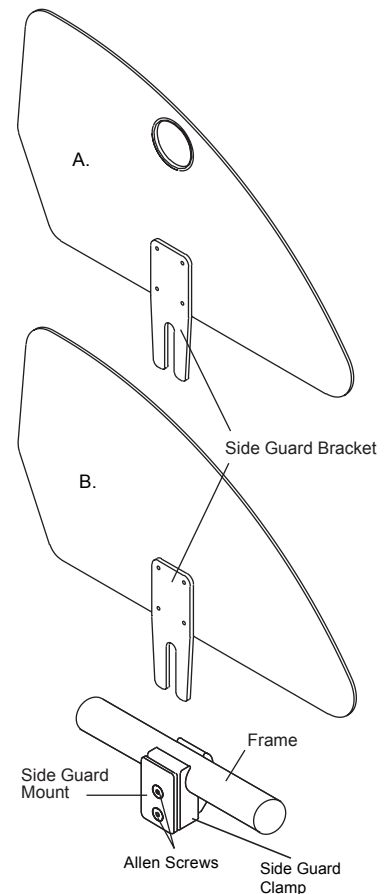

Figure 51
Quad Removable Side Guard (A) and Rigid Removable Side Guard (B)

installed.

Removing Rigid Side Guard Assembly

Tools Needed:

- 3/16" Allen Wrench

To remove the entire side guard assembly, including the side guard clamp:

1. Remove the side guard from the side guard mount.
2. Remove the Allen Screw that secures the two halves of the side guard clamp to the frame. See Figure 52.

Reinstalling Rigid Side Guard Assembly

Tools Needed:

- 3/16" Allen Wrench

1. Align the two halves of the side guard clamp around the seat tube of the chair frame. See Figure 52.
Note: On all chairs other than ZR Series and Aero Z chairs, the half of the side guard clamp to which the side guard mount is attached has a dowel pin protruding from the clamp that must be inserted in the side guard clamp hole in the frame. On ZR Series and Aero Z chairs, the side guard mount belongs on the outside of the frame.
2. Insert the Allen Screw into the two halves of the side guard clamp and securely tighten.
3. Insert the side guard bracket into the side guard mount and adjust the two Allen Screws as described under "Adjusting Rigid Side Guards" on page 46.

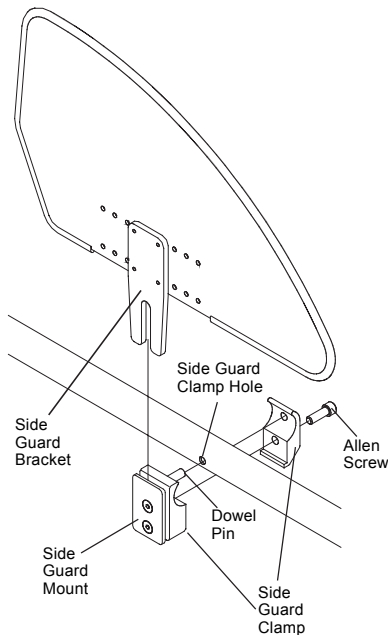

Figure 52
Removing/Replacing Side Guard Assembly

Fold-Down Rigid Side Guards

(Standard and Carbon Fiber)

(YG Series, ZR Series, Aero Z, TR, YR and Evo)

Using Fold-Down Side Guards

The fold-down side guards utilize an internal spring. To fold down, simply remove the seat cushion and push the top of the side guard toward the seat sling. To unfold, simply pull the side guard up away from the seat sling. See Figure 53.

Removing the Fold-Down Side Guard Assembly

Tools Needed:

- 3/8" Allen Wrench

1. Remove the two Allen Screws that secure the two

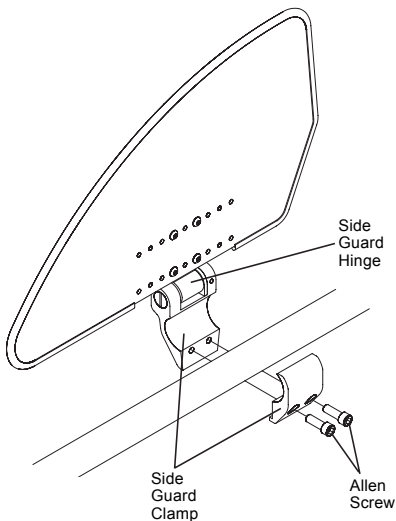

Figure 53
Fold-Down Rigid Side Guards

- halves of the side guard clamp. See Figure 53.
2. Remove the fold-down side guard clamp assembly.

Reinstalling Fold-Down Rigid Side Guard Assembly

Tools Needed:

- 3/8" Allen Wrench

1. Align the two halves of the side guard clamp around the seat tube of the frame. See Figure 53. **Note:** The half of the clamp with the side guard hinge attaches on the outside of the frame.
2. Insert the two Allen Screws through the washers and the two halves of the clamp and securely tighten.

CHAPTER 7: BACK UPHOLSTERY, SEAT UPHOLSTERY AND SEAT CUSHIONS

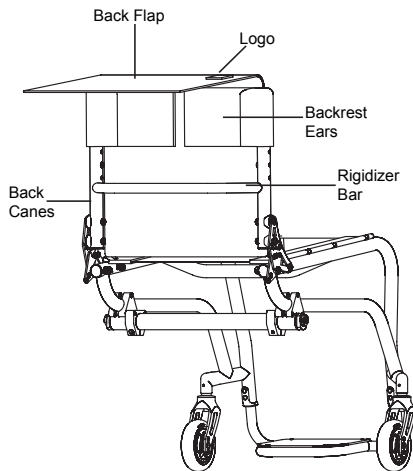

Figure 54
Adjusting Velcro Adjustable Back Upholstery

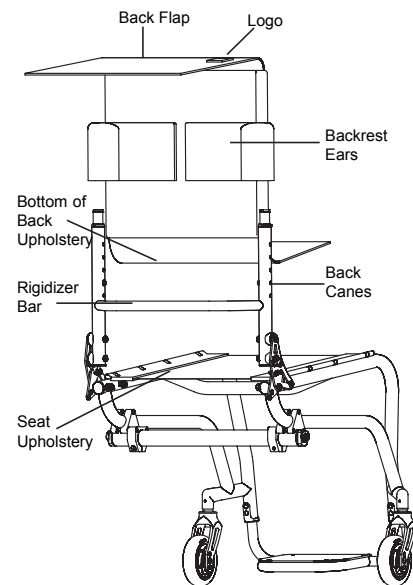

Figure 55
Replacing Velcro Adjustable Back Upholstery

Velcro Adjustable Back Upholstery

(TR Series, YG Series, YR Series, ZR Series, Aero Z and Evo)

Note: When adjusting the tension of the back upholstery, DO NOT apply so much tension that the back canes are pulled out of vertical. If this occurs, you may cause the chair to “track” improperly or to develop a “floater.”

Adjusting the Tension

1. Lift the back flap to expose the backrest ears. See Figure 54.
2. Completely detach the two backrest ears from the back upholstery, but do not remove them from the back canes.
3. Adjust to the desired tautness. The closer together the two backrest ears, the tauter the back upholstery will be. The farther apart the two backrest ears, the looser the back upholstery will be. Tighter back upholstery will increase the stability and maintain normal maneuverability of the chair because the user is pushed forward slightly. Looser back upholstery will increase maneuverability, but will make the chair more prone to tip over backward because additional weight is being distributed behind the rear wheels.
4. Align the top of the back upholstery with the two backrest ears to ensure that the top of the back upholstery is even with the top of the back canes.
5. Securely velcro the back upholstery to the backrest ears and lower the back flap back into position in front of the rigidizer bar.

Replacing the Upholstery

1. Lift the back flap to expose the backrest ears. See Figure 55.
2. Completely detach the two backrest ears from the back upholstery and remove them from the back canes.
3. Remove the seat cushion.
4. Detach the back upholstery from the seat upholstery by separating the Velcro at the underside of the seat upholstery. **Note:** On YG Series chairs, the backrest upholstery attaches to the top of the seat upholstery.
5. Attach new back upholstery to seat upholstery at the underside of the seat upholstery. **Note:** On YG Series chairs, the backrest upholstery attaches to the top of the seat upholstery.
6. Install the two backrest ears on the back canes.
7. Adjust to the desired tautness. See “Adjusting the Tension” on page 49.
8. Align the top of the back upholstery with the two backrest ears to ensure that the top of the back

- upholstery is even with the top of the back canes.
- Securely velcro the back upholstery to the backrest ears and lower the back flap back into position in front of the rigidizer bar.
 - Replace the seat cushion.

Tension Adjustable by Straps Back Upholstery

(TR Series, YG Series, YR Series, ZR Series, Aero Z, BB and Evo)

Note: When adjusting the tension of the back upholstery, DO NOT apply so much tension that the back canes are pulled out of vertical. If this occurs, you may cause the chair to “track” improperly or to develop a “floater.”

Adjusting the Tension

- Lift the back flap to expose the back straps/backrest ears (which are adjustable using Velcro). See Figure 56.
- Completely detach the back upholstery from the back straps/backrest ears. Do not remove the back straps/backrest ears from the back canes.
- Adjust to the desired tautness by loosening the Velcro back straps and then pulling on the loose end to pull the backrest ears closer together. Tighter back upholstery will increase the stability and maintain normal maneuverability of the chair because the user is pushed forward slightly. Looser back upholstery will increase maneuverability, but will make the chair more prone to tip over backward because additional weight is being distributed onto the rear wheels.
- Align the top of the back upholstery with the uppermost back strap.
- Securely velcro the back upholstery to the back straps/backrest ears and lower the back flap back into position in front of the rigidizer bar.

Replacing the Upholstery

- Lift the back flap to expose the back straps/backrest ears (which are adjustable using Velcro). See Figure 57.
- Completely detach the back straps/backrest ears from the back upholstery and remove them from the back canes.
- Remove the seat cushion.
- Detach the back upholstery from the seat upholstery by separating the Velcro at the underside of the seat upholstery. **Note:** On YG Series chairs, the back upholstery attaches to the top of the seat upholstery.
- Attach new back upholstery to seat upholstery at the underside of the seat upholstery. **Note:** On YG Series chairs, the back upholstery attaches to the top of the seat upholstery.
- Install the new back straps/backrest ears on the back canes.

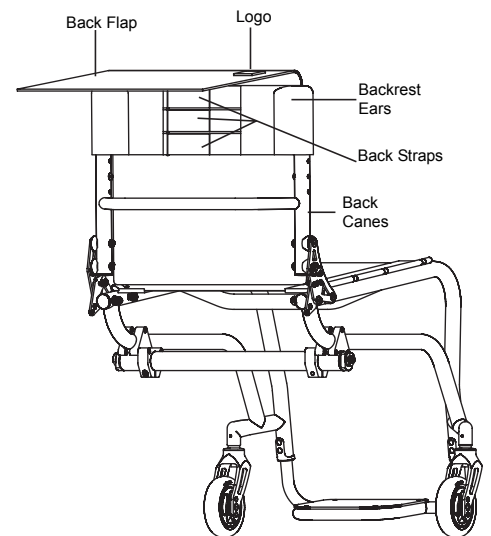

Figure 56
Adjusting Tension Adjustable by Straps Back Upholstery

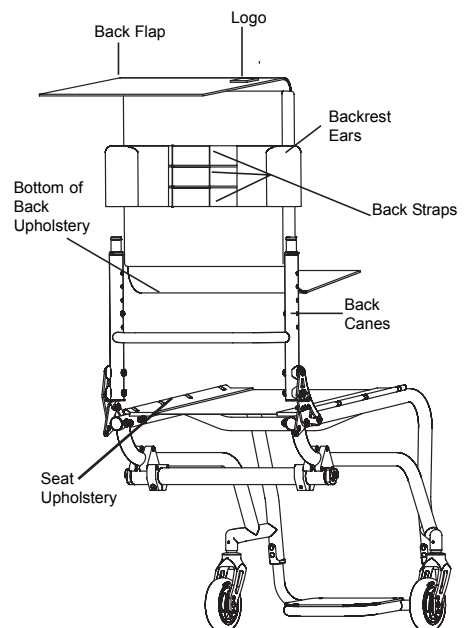

Figure 57
Replacing Tension Adjustable by Straps Back Upholstery

7. Adjust to the desired tautness. See “Adjusting the Tension” on page 50.
8. Align the top of the back upholstery with the uppermost back strap.
9. Securely velcro the back upholstery to the back straps/backrest ears and lower the back flap back into position in front of the rigidizer bar.
10. Replace the seat cushion.

Padded Black Nylon Back Upholstery

(BB)

If your BB chair is equipped with Padded Black Nylon Back Upholstery, this upholstery can be adjusted or replaced by following the procedures set forth under “Velcro Adjustable Back Upholstery” on pages 49 and 50.

Tension Adjustable By Straps Seat Sling Upholstery

(ZR Series, Aero Z, BB, TR and YR)

WARNING

Do not make the seat sling upholstery tension so loose that it does not properly support your weight. The sling should never be so loose that the sling causes your weight to be borne by the cross-tube below the seat sling. See Figure 58.

Adjusting the Tension

1. Remove the seat cushion.
2. Detach the back upholstery from the seat upholstery (see “Velcro Adjustable Back Upholstery” on pages 49-50 or “Tension Adjustable by Straps Back Upholstery” on pages 50-51).
3. Carefully tip the chair back until it is resting on its rear wheels and the backrest. Do not scratch the backrest tube.
4. Detach one Velcro tension adjustable strap, adjust to the desired tension and refasten the strap. See Figures 58 and 59.
5. Repeat Step 4 for each succeeding Velcro tension adjustable strap until you have achieved the desired tension in each strap.
6. Place the chair onto all four wheels.
7. Reattach the back upholstery to the seat upholstery and replace the seat cushion.

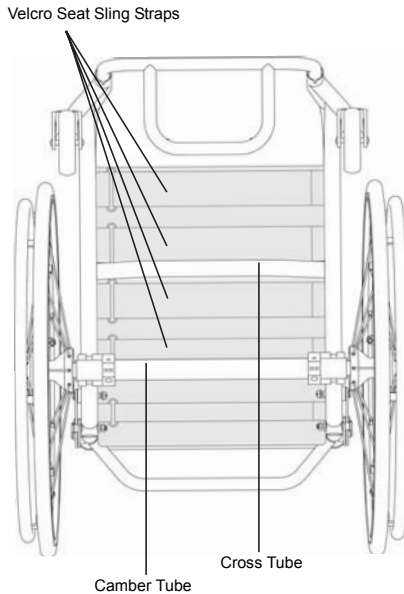

Figure 58
Tension Adjustable by Straps Seat Sling

Replacing the Upholstery

1. Remove the seat cushion.
2. Detach the back upholstery from the seat upholstery (see “Velcro Adjustable Back Upholstery” on pages 49-50 or “Tension Adjustable by Straps Back Upholstery” on pages 50-51).
3. Carefully tip the chair back until it is resting on its rear wheels and the backrest. Do not scratch the backrest tube.
4. Detach all Velcro tension adjustable straps that secure the seat upholstery to the frame.
5. Remove the existing seat upholstery.
6. Install the new seat upholstery making sure the straps hang over the left side of the frame (the left side if you were sitting in the chair). See Figure 59.
7. Slip the tension adjustable straps through the D-rings on the opposite side of the upholstery.
8. Adjust the seat sling to the desired tension and fasten the tension adjustable straps.
9. Place the chair onto all four wheels.
10. Reattach the back upholstery to the seat upholstery.

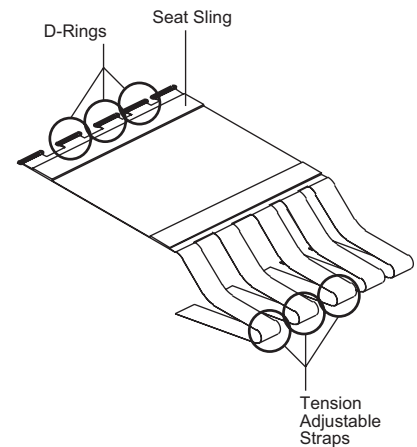

Figure 59
Tension Adjustable By Straps Seat Sling

Tension Adjustable Bolt-On Seat Sling

(TR Series, YG Series, YR Series, ZR Series, Aero Z and Evo)

WARNING

Do not make the seat sling upholstery tension so loose that it does not properly support your weight. The sling should never be so loose that the sling causes your weight to be borne by the cross-tube below the seat sling.

Adjusting the Tension

Tools required:

- 1/8" Allen Wrench

1. Remove the seat cushion.
2. Detach the back upholstery from the seat upholstery (see “Velcro Adjustable Back Upholstery” on pages 49-50 or “Tension Adjustable by Straps Back Upholstery” on pages 50-51).
3. Loosen, but do not remove, the Allen screws on the side of the seat upholstery where the Velcro adjustment flap is located on the underside of the seat upholstery. See Figure 60.
4. Detach the Velcro adjustment flap and adjust the seat upholstery to the desired tension.
5. Retighten the Allen screws that attach the seat upholstery to the frame. **Note:** this adjustment will be much easier if someone assists you by retightening the Allen screws while you hold the adjustment flap at the desired tension.
6. Reattach the back upholstery to the seat upholstery and replace the seat cushion.

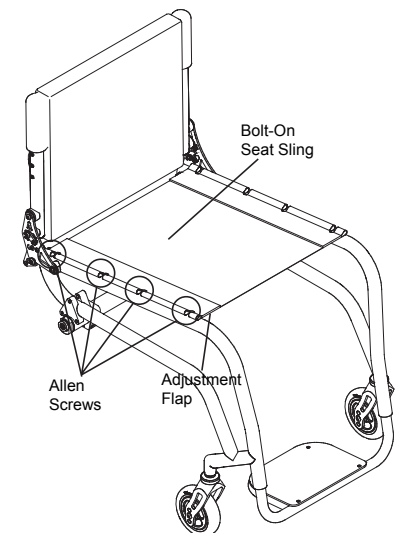

Figure 60
Adjusting Tension Adjustable Bolt-On Seat Sling

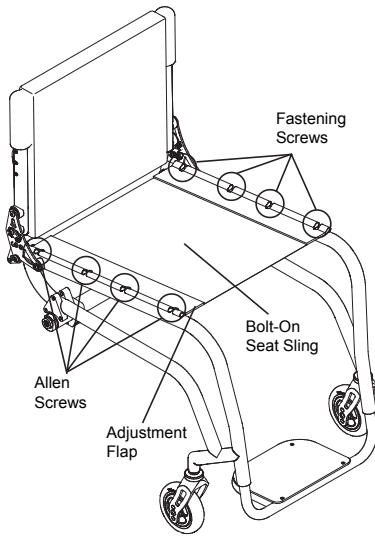

Figure 61
Replacing Tension Adjustable Bolt-On Seat Sling

Replacing the Upholstery

Tools required:

- 1/8" Allen Wrench

1. Remove the seat cushion.
2. Detach the back upholstery from the seat upholstery (see "Velcro Adjustable Back Upholstery" on pages 49-50 or "Tension Adjustable by Straps Back Upholstery" on pages 50-51).
3. Remove all Allen screws that attach the seat upholstery to the chair frame. See Figure 61.
4. Detach the Velcro adjustment flap and remove the bolt-on seat sling.
5. If your replacement upholstery included new aluminum seat rails, proceed to step 6. If not, remove the aluminum seat rails from old upholstery and insert them into the new upholstery.
6. Place the new seat upholstery on the frame and align the fastening holes in the upholstery and aluminum seat rails with the holes in the seat tubes of the frame.
7. Loosely install all the Allen screws on the side of the seat sling where the Velcro adjustment flap is located.
8. Install all the Allen screws on the opposite side of the seat sling and securely tighten all Allen screws.
9. Detach the Velcro adjustment flap and adjust the seat upholstery to the desired tension.
10. Fully tighten the Allen screws that attach the seat upholstery to the frame. **Note:** this adjustment will be much easier if someone assists you by retightening the Allen screws while you hold the adjustment flap at the desired tension.
11. Reattach the bottom of the back upholstery to the seat upholstery and replace the seat cushion.

TiLite Seat Cushion

(TR Series, YG Series, YR Series, ZR Series, Aero Z, BB and Evo)

Replacing the Foam Insert to Your TiLite Seat Cushion

1. Lift up and remove the existing seat cushion from the seat upholstery.
2. Unzip the seat cushion cover and remove the foam insert.
3. Insert the new foam insert into the seat cushion cover.
4. Close the seat cushion cover and replace on the chair.

For seat cushions manufactured by manufacturers other than TiLite (e.g. Corbee, StimuLite, Roho), consult the owner's manual provided by the applicable manufacturer.

CHAPTER 8: CAMBER TUBES (CENTER OF GRAVITY; REAR SEAT HEIGHT)

All TiLite rigid wheelchairs (other than the YG Series) are equipped with a standard camber tube, unless you have selected the optional Adjustable Camber System. By adjusting the position of the camber tube, you can adjust the center of gravity of your chair. In some cases, you also can adjust the rear seat height. This section explains the various adjustments that are possible.

WARNING

Any changes to the position of the camber tube will affect the stability of the chair. Use extreme caution when using a new camber tube position as the new position may make the chair more prone to tip over. *If you ignore this Warning, your chair may not perform properly, which in turn, may cause you to fall, tip over or lose control of the chair and seriously injure yourself or others or damage the chair.*

WARNING

Whenever you adjust the position of the camber tube (either to adjust the rear seat height or the center of gravity), it may be necessary to adjust the toe-in/toe-out of the rear wheels. See “Adjusting Toe-In/Toe-Out” on pages 62-63. In addition, whenever you adjust the position of the camber tube or when you adjust the toe-in/toe-out, it may be necessary to square the front casters to the floor. See “Adjustable Angle Caster Barrel (YG Series, TRA, YRA and Evo)” and “Angle Adjustable Bearing Fork (ZRA and Aero Z)” on pages 79-80. *If you ignore this Warning, your chair may not perform properly, which, in turn, may cause you to fall, tip over or lose control of the chair and seriously injure yourself or others or damage the chair.*

Note: To facilitate making the adjustments to rear seat height and center of gravity discussed in this chapter, it is recommended that you remove the rear wheels first and turn the chair upside down.

Standard Camber Tube

(TR Series, YR Series, ZR Series, Aero Z, BB and Evo)

Adjusting the Rear Seat Height
(ZRA and Aero Z)

Tools Needed:
• 3/16" Allen Wrench

1. Note the holes used to secure the camber tube mount to the camber mount bracket. See Figure 62.
2. On the right and left sides of your chair, remove the four Allen Screws and locknuts that secure the

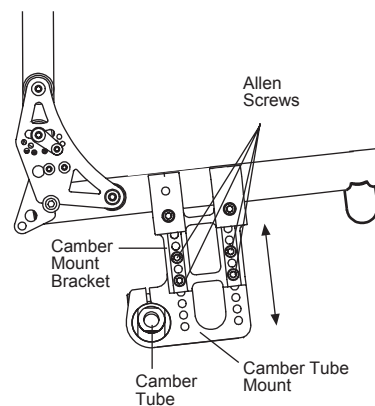

Figure 62
Adjusting the Rear Seat Height on the ZRA and Aero Z

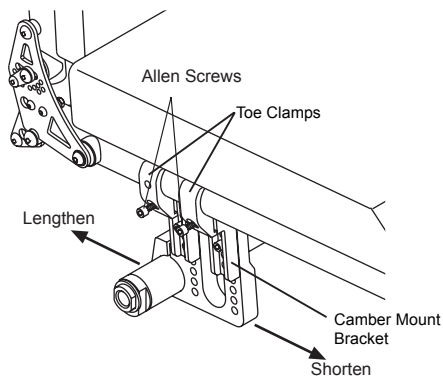

Figure 63
Adjusting the Center of Gravity on the ZRA and Aero Z

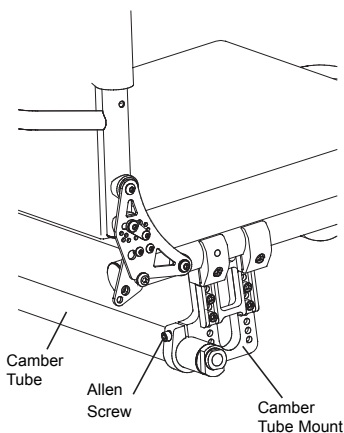

Figure 64
Replacing the Camber Tube on the ZRA and Aero Z

3. Reposition the camber tube mounts to the desired height—making sure to choose a height that will permit you to reattach the camber tube mounts to the camber mount brackets using all four Allen Screws on each side. Generally, there will be approximately 1-1/2" up or down adjustability, but the precise amount depends on the original dimensions of the chair you ordered.
4. Align the holes of the camber tube mounts and camber mount brackets.
5. On each side of the chair, reinstall the four Allen Screws and locknuts and securely tighten all eight screws.
6. Check the toe-in/toe-out and adjust as needed, and square the front casters as needed.

Adjusting the Center of Gravity (ZRA and Aero Z)

Tools Needed:

- 3/16" Allen Wrench
- Ruler

1. Loosen, but do not remove, the four (two on each side) Allen Screws that secure the toe clamps and the camber mount brackets to the frame. See Figure 63.
2. Slide the entire camber tube mounting assembly forward or rearward along the frame until it is positioned in the desired location. Use a ruler to ensure the assembly on both sides of the chair are the same distance from the ends of the frame tubes.
3. Securely tighten the four (two on each side) Allen Screws that secure the toe clamps and camber mount brackets to the frame.
4. Check the rear seat height and adjust as needed.
5. Check the toe-in/toe-out and adjust as needed and square the front casters as needed.

Note: The toe clamp/camber mount bracket axle assembly cannot be positioned further rearward than the position of the Allen Screw securing the backrest bracket to the frame. However, the rearward toe clamps have a hole to permit you to position this rearward toe clamp in line with the backrest bracket. Each ZRA and Aero Z wheelchair is shipped with a pair of longer Allen Screws and spare washers to permit you to make this adjustment.

Replacing the Camber Tube (ZRA and Aero Z)

Tools Needed:

- 3/16" Allen Wrench
- Ruler

1. Remove the rear wheels.
2. Loosen, but do not remove, the Allen Screw that secures the camber tube to each camber tube mount. See Figure 64.
3. Remove the camber tube.
4. Install the new camber tube, making sure that the distance from the outside edge of the camber tube mount to the end of the camber tube is identical on each side of the chair.
5. Securely tighten both Allen Screws.
6. Reinstall the rear wheels.
7. Check the toe-in/toe-out and adjust as needed and square the front casters as needed.

Adjusting the Center of Gravity (ZR)

WARNING

When repositioning the camber clamps on the CG Bracket (as described below), always leave as many open holes between the two Allen Screws as your desired placement will permit. NEVER use two adjacent holes to attach the camber clamp to the CG Bracket. *If you ignore this Warning, your camber clamp may fail, causing you to fall, tip over or lose control of the chair and seriously injure yourself or others or damage the chair.*

Tools Needed:

- 3/16" Allen Wrench
- Ruler

1. Remove the rear wheels.
2. Remove the four Allen Screws (two on each side of the chair) that secure the Camber Clamps to the CG Bracket. See Figure 65.
3. Reposition the Camber Clamps to the desired position on the CG Brackets, making absolutely sure the positioning is the same on both sides of the chair. You **MUST** leave one open hole between the two Allen Screws.
4. Reinstall the Allen Screws and lock washers and securely tighten all four Allen Screws.
5. Reinstall the rear wheels.
6. Check the toe-in/toe-out and adjust as needed.

Replacing the Camber Tube (ZR)

Tools Needed:

- 3/16" Allen Wrench
- Ruler

1. Remove the rear wheels.
2. Loosen, but do not remove, the Allen Screw that secures the camber tube to each camber clamp. See Figure 66.

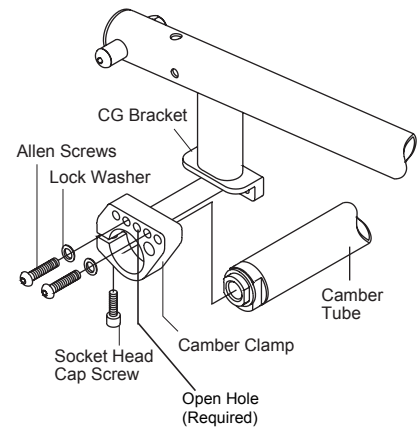

Figure 65
Adjusting the Center of Gravity of the ZR

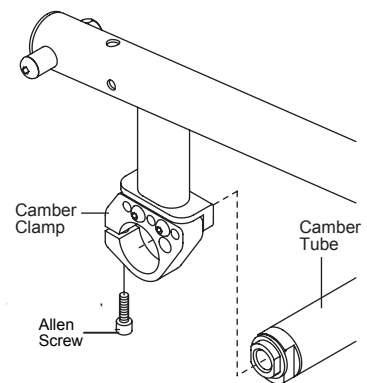

Figure 66
Replacing Camber Tube on ZR

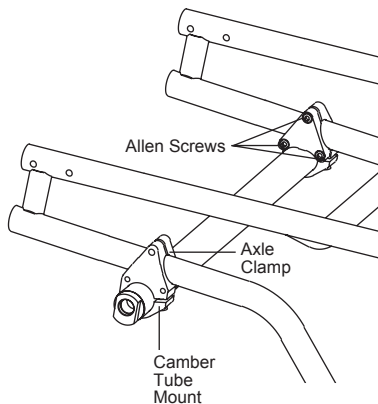

Figure 67
Adjusting the Center of Gravity of the TR, YR and BB

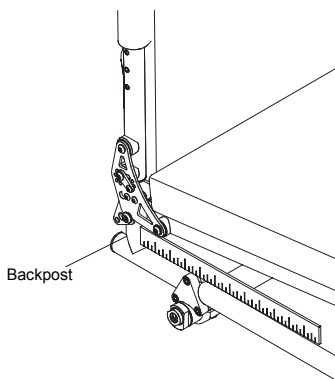

Figure 68
Adjusting the Center of Gravity of the TR, YR and BB

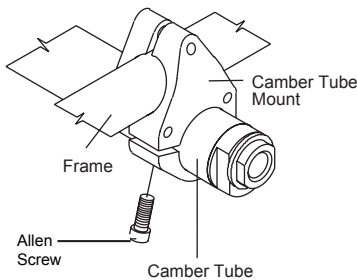

Figure 69
Replacing Camber Tube on TR, YR and BB

3. Remove the camber tube.
4. Install the new camber tube, making sure the distance from the outside edge of the camber clamp to the end of the camber tube is identical on each side of the chair.
5. Securely tighten both Allen Screws.
6. Reinstall the rear wheels.
7. Check the toe-in/toe-out and adjust as needed.

Adjusting the Center of Gravity (TR, YR and BB)

Tools Needed:

- 3/16" Allen Wrench
- Ruler

1. Remove the rear wheels.
2. Loosen, but do not remove, the six Allen Screws (three on each side of the chair) that secure the axle clamps and camber tube mounts to the frame. See Figure 67.
3. Simultaneously slide both camber tube clamping assemblies forward or rearward along the frame until they are positioned in the desired location. Use a ruler to ensure both camber tube clamping assemblies are the same distance from the back post (measured from the back post to the top of the clamping assembly). See Figure 68.
4. Securely tighten the six Allen Screws that secure the axle clamps and camber tube mounts to the frame.
5. Reinstall the rear wheels.
6. Check the toe-in/toe-out and adjust as needed.

Replacing the Camber Tube (TR, YR and BB)

Tools Needed:

- 3/16" Allen Wrench
- Ruler

1. Remove the rear wheels.
2. Loosen, but do not remove, the Allen Screw that secures the camber tube to each camber tube mount. See Figure 69.
3. Remove the camber tube.
4. Install the new camber tube, making sure the distance from the outside edge of the camber tube mount to the end of the camber tube is identical on each side of the chair.
5. Securely tighten both Allen Screws.
6. Reinstall the rear wheels.
7. Check the toe-in/toe-out and adjust as needed.

Adjusting the Rear Seat Height (TRA and YRA)

The TRA and YRA chairs have a seven position axle plate (see Figure 70A) to permit a wide range of adjustability to the rear seat height.

Tools Needed:

- 3/16" Allen Wrench
- 7/16" Open End Wrench

1. Remove the rear wheels.
2. Remove the camber tube. See "Replacing the Camber Tube" on page 59.
3. Remove the three Allen Screws that secure the axle plate to the camber mounts. See Figure 70B.
4. Reposition the axle plate to desired height, making sure three holes in the axle plate (two outer holes and one center hole) align with the three holes in the camber mounts. **Note:** In position 0, it will be necessary to remove the Allen Screws that secure the camber tube clamp to the axle plate. See Figure 70C.
5. Reinstall the three Allen Screws that secure the axle plate to the camber mounts and the frame. Note that the non-threaded camber mount must be flush against the axle plate. The threaded camber mount should be on the opposite side of the frame tube from the axle plate.
6. Repeat steps 2 through 4 with the axle plate and camber mounts on the opposite side of the chair.
7. Securely tighten all Allen Screws.
8. Reinstall the camber tube. See "Replacing the Camber Tube" on page 59.
9. Reinstall the rear wheels.
10. Check the toe-in/toe-out and adjust as needed and square the front casters as needed.

Note: The camber tube may be mounted either above or below the frame tube. In most instances, making a rear seat height adjustment will not require reversing this configuration. However, if necessary you can reverse the direction of the camber tube mounts to switch the position of the camber tube from above the frame tube to below it or vice versa. See Figure 70D.

Adjusting the Center of Gravity (TRA and YRA)

Tools Needed:

- 3/16" Allen Wrench
- Ruler

1. Remove the rear wheels.
2. Loosen, but do not remove, the six Allen Screws (three on each side of the chair) that secure the axle plates to the camber mounts. See Figure 70B.

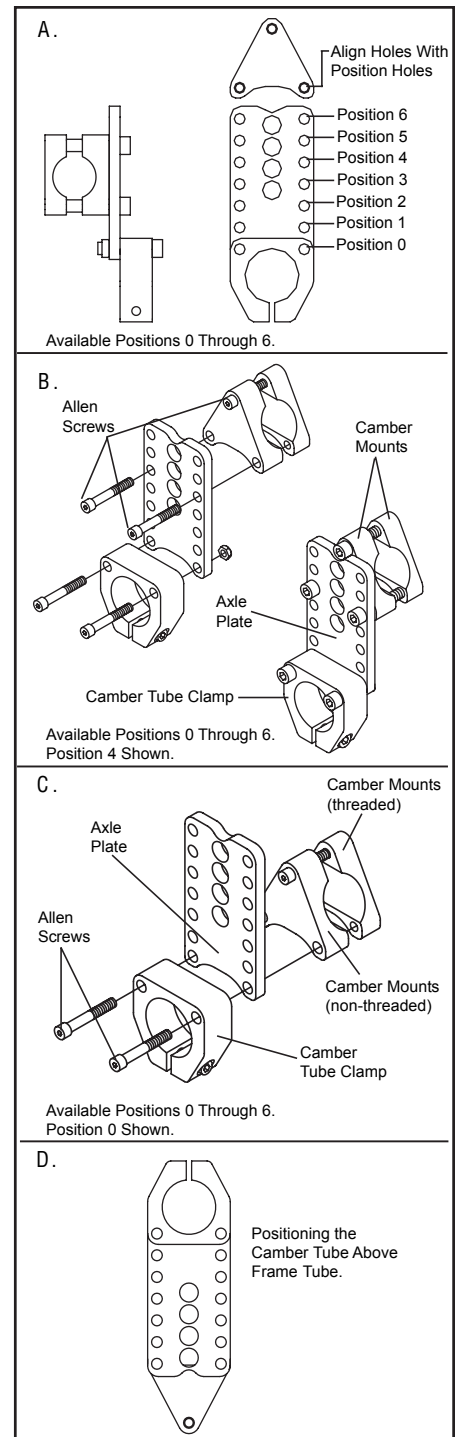

Figure 70
TRA/YRA Camber Tube and Axle Plate Positions

3. Simultaneously slide both camber tube clamping assemblies forward or rearward along the frame until they are positioned in the desired location. Use a ruler to ensure that both camber tube clamping assemblies are the same distance from the vertical frame tube at the rear of the frame. See Figure 68.
4. Securely tighten all six Allen Screws.
5. Reinstall the rear wheels.
6. Check the toe-in/toe-out and adjust as needed and square the front casters as needed.

Replacing the Camber Tube (TRA and YRA)

Tools Needed:

- 3/16" Allen Wrench
- Ruler

1. Remove the rear wheels.
2. Loosen, but do not remove, the Allen Screw that secures the camber tube to each camber tube clamp. See Figure 71.
3. Remove the camber tube.
4. Install the new camber tube, making sure the distance from the outside edge of the camber tube clamp to the end of the camber tube is identical on each side of the chair.
5. Securely tighten both Allen Screws.
6. Reinstall the rear wheels.
7. Check the toe-in/toe-out and adjust as needed and square the front casters as needed.

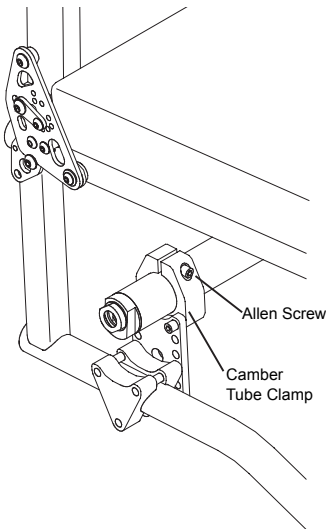

Figure 71
Replacing the TRA/YRA Camber Tube

Adjusting the Rear Seat Height (Evo)

Tools required

- 5/32" Allen Wrench
- 7/16" Open End Wrench

1. Remove the rear wheels.
2. Remove the camber tube. See "Replacing the Camber Tube (Evo)" on page 61.
3. Remove the four Allen Screws (two on each side of the chair) that secure the adjustable axle plates to the frame. Carefully note the order in which the various washers and nuts (and any other parts, such as anti-tip receptacles) were originally installed on your chair as you will need to reinstall all of these parts in the exact same order in Step 5 below. See Figure 72.
4. Reposition one adjustable axle plate to desired height, making sure that one hole at either end of the axle plate aligns with one hole in the frame. Note that the holes in the frame are spaced in 1" increments and the holes in the adjustable axle plate are spaced in 1/2" increments, making the height adjustable in 1/2" increments. Also note that if your chair is equipped with armrests and/or anti-tips, you may need to raise or lower these by the same amount you raise or lower the adjustable axle plate.

In this case, you may need to adjust the height of the armrest (see “Adjusting the Height of the Tubular Swing Away Armrest (TRA, YRA and Evo)” on page 41) and/or the anti-tippers (see “Rear Anti-Tips” on pages 86 and 87) in order to compensate for raising or lowering the armrest and/or anti-tip receiver.

5. Reinstall the two Allen Screws that secure the adjustable axle plate to the frame, making sure all washers and nuts (and any other parts, such as anti-tip receptacles) are reinstalled in the exact same order as they were originally installed.
6. Repeat steps 4 and 5 with the adjustable axle plate on the opposite side of the chair. Make sure the second adjustable axle plate is mounted in exactly the same location on the opposite side of the frame.
7. Securely tighten all four Allen Screws.
8. Reinstall the rear wheels.
9. Check the toe-in/toe-out and adjust as needed and square the front casters as needed.

Note: The camber tube may be mounted either above or below the adjustable axle plate. In most instances, making a rear seat height adjustment will not require reversing this configuration. However, if necessary you can reverse the direction of the adjustable camber clamps to switch the position of the camber tube from above the adjustable axle plate to below it or vice versa. See Figure 72.

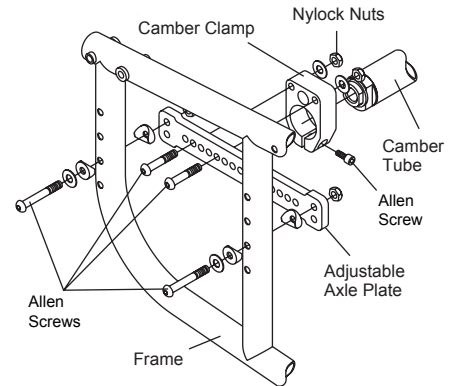

Figure 72
Adjusting the Camber Tube on the Evo

Adjusting the Center of Gravity (Evo)

Tools Needed:

- 5/32" Allen Wrench
- 7/16" End Wrench

1. Remove the rear wheels.
2. Remove the four Allen Screws (two on each side of the chair) that secure the camber clamps to the adjustable axle plates. See Figure 72.
3. Reposition one camber clamp to the desired location and align the two holes in the adjustable camber clamp with two holes in the adjustable axle plate.
4. Reinsert the two Allen Screws through the adjustable axle plate, the adjustable camber clamp and the nylock locknuts.
5. Repeat steps 3 and 4 with the adjustable camber clamp on the opposite side of the chair. Make sure the second camber tube clamp is mounted in exactly the same location on the opposite side of the frame.
6. Securely tighten all four Allen Screws.
7. Reinstall the rear wheels.
8. Check the toe-in/toe-out and adjust as needed and square the front casters as needed.

Replacing the Camber Tube (Evo)

Tools Needed:

- 3/16" Allen Wrench
- Ruler

1. Remove the rear wheels.
2. Loosen, but do not remove, the Allen Screw that secures the camber tube to each camber clamp. See Figure 72.
3. Remove the camber tube.
4. Install the new camber tube, making sure the distance from the outside edge of the adjustable camber clamp to the end of the camber tube is identical on each side of the chair.
5. Securely tighten both Allen Screws.
6. Reinstall the rear wheels.
7. Check the toe-in/toe-out and adjust as needed and square the front casters as needed.

YG SERIES CAMBER TUBES

Adjusting the Rear Seat Height

Tools required

- 5/32" Allen Wrench
- 7/16" Open End Wrench

1. Remove the rear wheels.
2. Remove the eight Allen Screws (four on each side of the chair) that secure the adjustable axle plates to the frame. Carefully note the order in which the various washers and nuts (and, in certain cases, the stroller handle receptacle and/or anti-tip receptacle) were originally installed on your chair as you will need to reinstall all of these parts in the exact same order in Step 4 below. See Figure 73.
3. Reposition one adjustable axle plate to desired height, making sure that two holes at either end of each adjustable axle plate align with two holes in the frame. Note that the holes in the frame are spaced in 1" increments and the holes in the adjustable axle plate are spaced in 1/2" increments, making the height adjustable in 1/2" increments. Also note that the adjustable axle plate is not vertically symmetrical, providing greater flexibility in rear seat height adjustment.
4. Reinstall the four Allen Screws that secure the adjustable axle plate to the frame, making sure that all washers and nuts (and, in some cases, the stroller handle receptacle and/or anti-tip receptacle) are reinstalled in the same order as they were originally installed.
5. Repeat steps 3 and 4 with the adjustable axle plate on the opposite side of the chair. Make sure the second adjustable axle plate is mounted in exactly the same location on the opposite side of the frame.

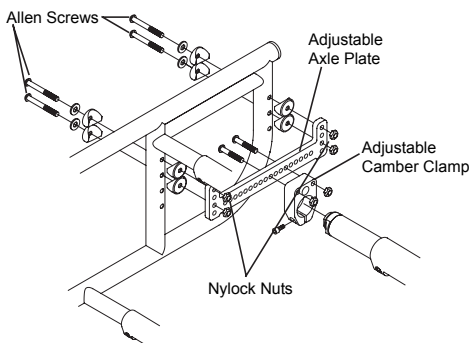

Figure 73
Adjusting the Rear Seat Height of the YG/YGS

6. Securely tighten all eight Allen Screws.
7. Check the toe-in/toe-out and adjust as needed, and square the front casters as needed.

Note: The camber tube may be mounted either above or below the adjustable axle plate. In most instances, making a rear seat height adjustment will not require reversing this configuration. However, if necessary you can reverse the direction of the adjustable camber tube clamps to switch the position of the camber tube from above the adjustable axle plate to below it or vice versa. See Figure 74.

Note: Figure 73 shows the adjustable axle plate mounted on the inside of the frame, which is standard. However, if desired, the adjustable axle plate may be mounted on the outside of the frame.

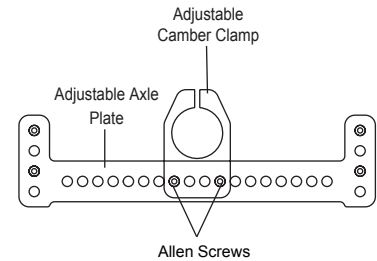

Figure 74
Adjusting the Axle Position on the YG/YGS

Adjusting the Center of Gravity

Tools Needed:

- 5/32" Allen Wrench
- 7/16" End Wrench

1. Remove the rear wheels.
2. Remove the four Allen Screws (two on each side of the chair) and nylock locknuts that secure the adjustable camber clamps to the adjustable axle plates. See Figures 73 and 74.
3. Reposition the adjustable camber clamp to the desired location and align the two holes in the adjustable camber clamp with two holes in the adjustable axle plate.
4. Reinsert the two Allen Screws through the adjustable axle plate, the adjustable camber clamp and the nylock locknuts.
5. Repeat steps 3 and 4 with the adjustable camber clamp on the opposite side of the chair. Make sure the second adjustable camber clamp is mounted in exactly the same location on the opposite side of the frame.
6. Securely tighten all four Allen Screws.
7. Check the toe-in/toe-out and adjust as needed, and square the front casters to the floor as needed.

Adjusting Toe-In/Toe-Out

(TR Series, YG Series, YR Series, ZR Series, Aero Z, BB and Evo)

Tools Needed:

- 3/16" Allen Wrench
- 7/8" Open End Wrench
- Ruler or Tape Measure
- Bubble Level or Angle Finder (YG Series only)

Note: Adjusting toe-in/toe-out with standard camber tubes does not apply to chairs with 0° camber.

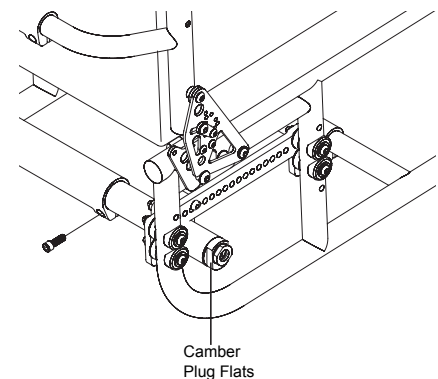

Figure 75
Adjusting the Toe-In/Toe-Out

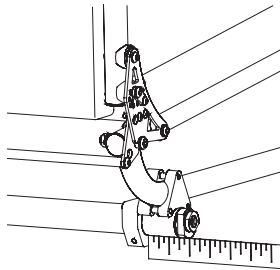

Figure 76
Adjusting Toe-In/Toe-Out

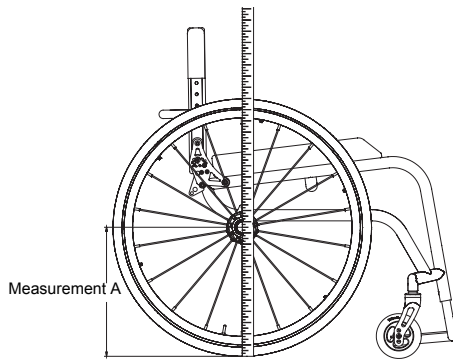

Figure 77
Adjusting Toe-In/Toe-Out

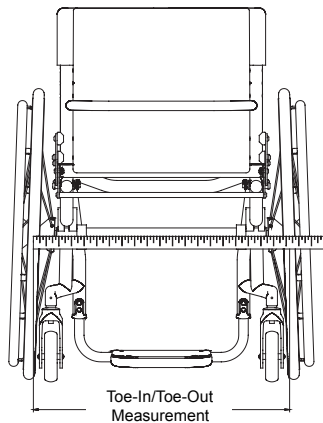

Figure 78
Adjusting Toe-In/Toe-Out

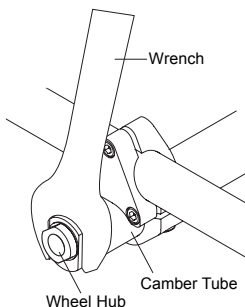

Figure 79
Rotating the Camber Tube

Note: On YG Series chairs, before starting this procedure you must make sure the camber plug flats (see Figure 75) are identically oriented on both sides of the chair. A bubble level or angle finder can be used to check this. If it is necessary to adjust the two halves of the YG Series camber tube so as to correctly orient the camber plug flats, you will need to loosen the Allen Screws on the camber tube expansion bracket (see Figure 135 on page 91). Whether or not the adjustment described in the previous sentence is necessary, before starting the procedure below you must make sure the camber tube expansion bracket (see Figure 135 on page 91) is fully tightened so the two halves of the YG Series camber tube will rotate as one integral unit.

1. Make sure the distance from the end of the camber tube to the camber mount clamp is identical on both sides of the chair. See Figure 76.
2. Make sure the rear wheels are properly inflated.
3. Place the chair on all four wheels with the front casters trailing toward the rear of the frame. See Figure 77.
4. Measure from the floor to the center of the axle ("Measurement A"). Be sure the tape measure/ruler is perpendicular to the floor.
5. Block the wheels with a heavy object so the chair can not roll forward or backward (do not use the wheel locks as this may affect the toe-in/toe-out adjustment).
6. Measuring from the floor at the rear of each tire, mark the tire (with a felt tip pen) at the same height as Measurement A.
7. Measuring from the floor at the front of each tire, mark the tire (with a felt tip pen) at the same height as Measurement A.
8. Measure the distance between the left and right tires at the rear reference marks made in step 6. See Figure 78.
9. Measure the distance between the left and right tires at the front reference marks made in step 7.
10. If the measurements in steps 8 and 9 are the same (within 1/8"), no toeing adjustment is needed, and you may skip to step 13. If not, proceed to step 11.
11. Loosen the Allen Screw in each camber mount clamp that secures the camber tube in place.
12. If the measurement in step 9 is less than the measurement in step 8, rotate the camber tube using the 7/8" Open End Wrench rearward to toe-out the rear wheels. If the measurement in step 9 is greater than the measurement in step 8, rotate the camber tube using the 7/8" Open End Wrench forward to toe-in the rear wheels. Continue adjusting the camber tube until these two measurements are equal. See Figure 79.
13. Securely tighten the Allen Screws in the camber tube mount.
14. Square the front casters to the floor.

Adjustable Camber System (TR and YR)

Adjusting the Skewer Handle Tension

1. Release the handle on the skewer to the unlocked position. See Figure 80.
2. Loosen or tighten the Allen Screw on the end of the skewer.
3. Return the handle of the skewer to the locked position.

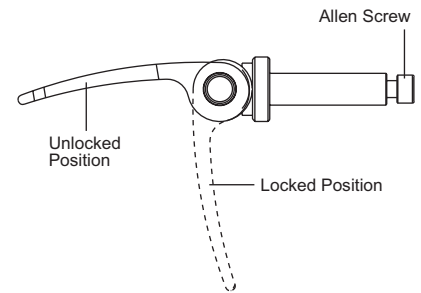

Figure 80
Adjusting Skewer Handle Tension

Changing the Camber

Tools Needed:

- 3/8" Allen Wrench

1. Remove the rear wheels and turn your chair upside down.
2. Unlock all four skewers. See Figure 81.
3. Remove the two Allen Screws and the two retaining plates from the rear side of the adjustable camber mounting plate.
4. Remove all four skewers from adjustable camber mounting plate.
5. Using Figure 82, determine the placement of the retaining plate and skewers that will achieve your desired camber.
6. Reposition the axle sleeve mounts to the desired camber position, making sure to align the holes in the axle sleeve mount with the holes on the front and rear adjustable camber mounting plates. See Figure 82.
7. Reinsert the skewers through the adjustable camber mounting plates and the axle sleeve mounts.
8. Reinstall the retaining plates and Allen Screws at the rear side of the adjustable camber mounting.
9. Return the handles of all four skewers to the locked position.
10. Reinstall the rear wheels and turn the chair right side up.
11. Check the toe-in/toe-out and adjust as needed.

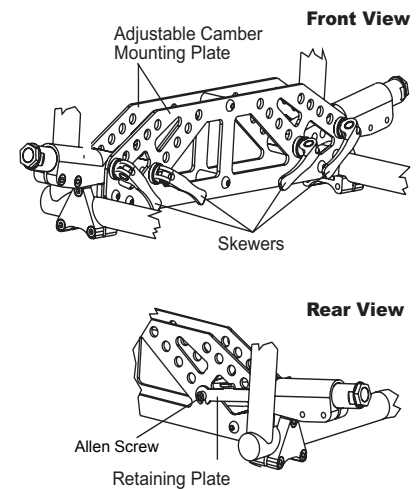

Figure 81
Adjustable Camber System

Adjusting Rear Wheel Spacing

Tools Needed:

- 3/16" Allen Wrench

⚠ WARNING

Do not extend the camber plug more than 1-1/2" out of the axle sleeve mount. If more than 1-1/2" of the camber plug is outside of the axle sleeve mount, the camber plug could disengage from the axle sleeve mount while you are using the chair. *If you ignore this Warning, you may fall, tip over or lose control of the wheelchair and seriously injure yourself or others or damage the wheelchair.*

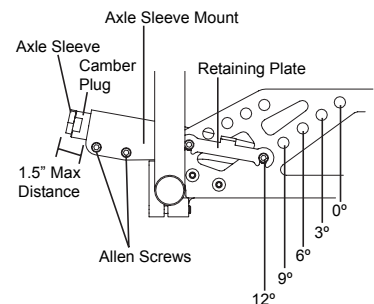

Figure 82
Camber Settings

1. Remove the rear wheels.

2. Loosen, but do not remove, the two Allen Screws located on the axle sleeve mount on each side of your chair. Only loosen the screws enough to permit the camber plug to slide in and out of the axle sleeve mount. See Figure 82.
3. Slide the camber plugs in or out of the axle sleeve mounts to increase or decrease the rear wheel spacing. Make sure the distance from the end of the axle sleeve to the end of the axle sleeve mount is the same on both sides of the chair.
4. Securely tighten all four Allen Screws in the axle sleeve mounts.
5. Reinstall the rear wheels.
6. Check the toe-in/toe-out and adjust as needed.

Adjusting Toe-In/Toe-Out with Adjustable Camber System

Tools Needed:

- 3/16" Allen Wrench
- Ruler or Tape Measure

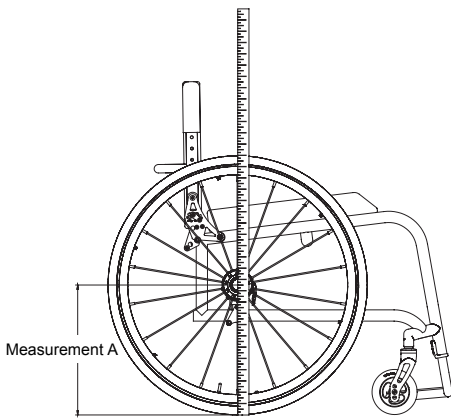

Figure 83
Adjusting Toe-In/Toe-Out

1. Make sure both rear wheels are equally spaced. See "Adjusting Real Wheel Spacing" on pages 64-65.
2. Make sure the rear wheels are properly inflated.
3. Place the chair on all four wheels with the front casters trailing toward the rear of the frame. See Figure 83.
4. Measure from the floor to the center of the axle ("Measurement A"). Be sure the tape measure/ruler is perpendicular to the floor. See Figure 83.
5. Block the wheels with a heavy object so the chair can not roll forward or backward (do not use the wheel locks as this may affect the toe-in/toe-out adjustment).
6. Measuring from the floor at the rear of each tire, mark the tire (with a felt tip pen) at the same height as Measurement A.
7. Measuring from the floor at the front of each tire, mark the tire (with a felt tip pen) at the same height as Measurement A.
8. Measure the distance between the left and right tires at the rear reference marks made in step 6. See Figure 84.
9. Measure the distance between the left and right tires at the front reference marks made in step 7.
10. If the measurements in steps 8 and 9 are the same (within 1/8"), no toeing adjustment is needed, and you may skip to step 13. If not, proceed to step 11.
11. Loosen the two Allen Screws in each axle sleeve mount that secure the camber plug in place. See Figure 82.
12. If the measurement in step 9 is less than the measurement in step 8, rotate both axle sleeves rearward to toe-out the rear wheels. If the measurement in step 9 is greater than the measurement in step 8, rotate both axle sleeves forward to toe-in the wheels. Continue adjusting the

axle sleeves until these two measurements are equal.

13. Measure the distance from the seat tube to the inside of the tire at the front of each tire on both sides of the frame ("Measurement B"). See Figure 85.
14. If Measurement B is the same on both sides of the chair, proceed to step 17.
15. If Measurement B is not the same on both sides of the chair, you will need to rotate the camber plugs in the axle sleeve mounts as necessary to make sure Measurement B is equal on both sides of the chair. Make sure when you rotate the camber plugs, you do not affect the rear wheel spacing. See "Adjusting Rear Wheel Spacing" on pages 64-65.
16. After adjusting the camber plugs in step 15, it will be necessary to recheck the toe-in/toe-out. See steps 6 through 10 above.
17. Securely tighten the Allen Screws in the axle sleeve mounts. See Figure 82.

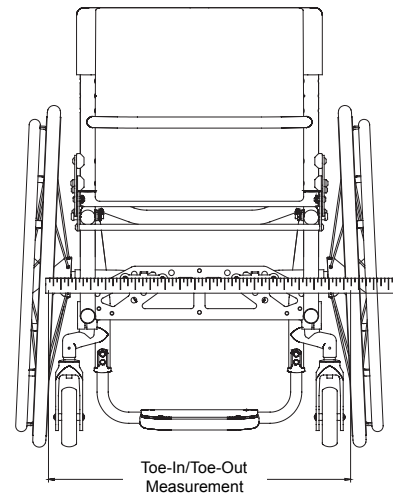

Figure 84
Adjusting Toe-In/Toe-Out

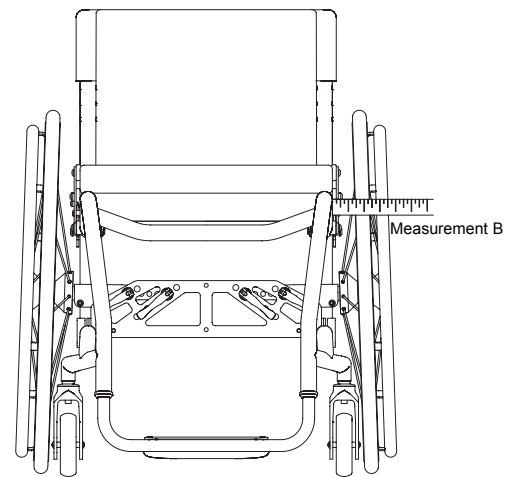

Figure 85
Adjusting Toe-In/Toe-Out

CHAPTER 9: AXLES AND AMPUTEE ADAPTERS

WARNING

Do not attempt any of the procedures in this Chapter when the chair is occupied. *If you ignore this Warning, you may fall, tip over or lose control of the wheelchair and seriously injure yourself or others or damage the wheelchair.*

Stainless and Titanium Quick Release Axles

(TR Series, YG Series, YR Series, ZR Series, Aero Z, BB and Evo)

Adjusting the Quick-Release Axle

WARNING

Quick release axles are pre-adjusted to permit minimal “play” in the axle. TiLite recommends that you do not adjust the axle. Improperly adjusting the axle could cause it to malfunction—too much play can cause the axle to bend and become stuck in the axle sleeve; too little play can prevent the locking balls from engaging fully, causing the wheel to disengage from the chair without warning. TiLite recommends that any adjustments be made by an authorized TiLite dealer. *If you ignore this Warning, you may fall, tip over or lose control of the wheelchair and seriously injure yourself or others or damage the wheelchair.*

Tools Needed:

- 3/4” End Wrench
- 7/16” End Wrench

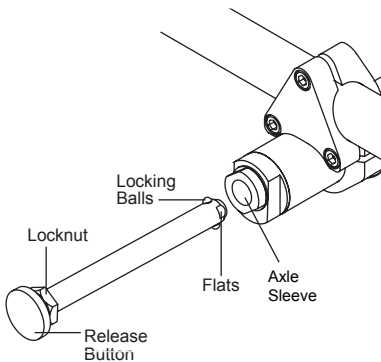

Figure 86
Adjusting the Quick Release Axle

1. Depress the release button and remove rear wheel and quick release axle. See Figure 86.
2. Remove axle from the wheel by depressing the release button and sliding the axle through the rear wheel hub.
3. Once removed from the hub, release the release button (the locking balls should be fully extended).
4. Increase or decrease axle play by adjusting the locknut while securing the opposite end of the axle using the smaller wrench at the flats at the end of the axle.
5. Depress the release button on the quick release axle and slide the axle through the rear wheel hub.
6. Depress the release button and reinstall rear wheel into the axle sleeve.
7. Before riding in the chair, make sure the locking balls have fully secured the wheel in the axle sleeve by pulling on the hub without depressing the release button on the quick release axle. If the locking balls do not fully engage, repeat these procedures and increase the play (i.e., increase the distance between the locknut and the locking balls) to permit the locking balls to fully engage properly. Also check to make sure there is not too much play in the axle.

Quad Quick-Release Axles

(TR Series, YG Series, YR Series, ZR Series, Aero Z, BB and Evo)

Adjusting the Quad Quick Release Handle

WARNING

Quick release axles are pre-adjusted to permit minimal “play” in the axle. TiLite recommends that you do not adjust the axle. Improperly adjusting the axle could cause it to malfunction—too much play can cause the axle to bend and become stuck in the axle sleeve; too little play can prevent the locking balls from engaging fully, causing the wheel to disengage from the chair without warning. TiLite recommends that any adjustments be made by an authorized TiLite dealer. *If you ignore this Warning, you may fall, tip over or lose control of the wheelchair and seriously injure yourself or others or damage the wheelchair.*

If there is no play in the quad quick release handle, or if the release handle does not flip back and forth from locked to unlocked properly, or if you cannot fully engage it in the locked position or the unlocked position, the procedure below will permit you to adjust the operation of the handle.

Tools Needed:

- 5/64” Allen Wrench

1. Flip the quick release handle to the unlocked position and remove rear wheel and quick release axle. See Figure 87.
2. Flip quick release handle to locked position.
3. To adjust the “play” between the quick release handle and the release button inside the quick release nut: (a) loosen Set Screw 2 on the quick release nut; (b) rotate the quick release nut clockwise or counter-clockwise on the axle until the release button inside the quad quick release nut just touches the release handle while it is in the locked position; and (c) tighten Set Screw 2.
4. Adjusting the “play” in the quick release handle may necessitate an adjustment to the “play” between the collar and the wheel hub. See “Adjusting the Play” on page 69.
5. With the quick release handle in the unlocked position, reinstall the rear wheel on the chair.
6. Before riding in the chair, make sure the locking balls have fully secured the wheel in the axle sleeve by pulling on the hub with the release handle in the locked position. If the locking balls do not fully engage, repeat these procedures to increase the “play” (i.e., increase the distance between the quick release nut and the locking balls), to permit the locking balls to fully engage properly. Also check to make sure there is not too much play in the axle. See “Adjusting the Play” on page 69.

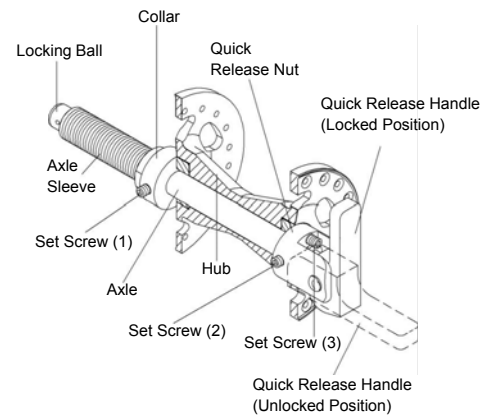

Figure 87
Quad Quick Release Axle Adjustment

Adjusting the “Play”

Tools Needed:

- 5/64” Allen Wrench

WARNING

Quick release axles are pre-adjusted to permit minimal “play” in the axle. TiLite recommends that you do not adjust the axle. Improperly adjusting the axle could cause it to malfunction—too much play can cause the axle to bend and become stuck in the axle sleeve; too little play can prevent the locking balls from engaging fully, causing the wheel to disengage from the chair without warning. TiLite recommends that any adjustments be made by an authorized TiLite dealer. *If you ignore this Warning, you may fall, tip over or lose control of the wheelchair and seriously injure yourself or others or damage the wheelchair.*

If there is too much play in the axle so the wheel is loose when locked into position in the axle sleeve or too little play so the locking balls do not properly engage, follow this procedure:

1. Flip the quick release handle to the unlocked position and remove rear wheel and quick-release axle. See Figure 87.
2. Adjust Set Screw 3 on the quick release nut so that no portion of Set Screw 3 is protruding out of the opposite side of the quick release nut (the side adjacent to the wheel hub).
3. Loosen Set Screw 1 on the collar.
4. Replace the wheel on the chair.
5. With the wheel still on the chair and the quad quick release handle in the locked position so the locking balls are fully engaged, securely tighten Set Screw 1 so the collar is securely on the axle sleeve.
6. With the release handle in the unlocked position, turn Set Screw 3 clockwise to remove any remaining play between the wheel hub and collar.
7. Flip the quad quick release handle to the locked position and check the “play” in the axle. Make sure the locking balls fully engage and lock the axle into the camber tube. If there is still too much play in the axle, repeat the procedure in step 6. If you have taken too much play out of the axle, repeat the procedure in step 6, but turn Set Screw 3 counter-clockwise to add play to the axle.
8. Before riding in the chair, check the play in wheel and check to make sure the locking balls have fully secured the axle inside the axle sleeve by pulling on the hub with the quad quick release handle in the locked position. If the locking balls do not properly engage or there is too much play, return to Step 1 and repeat this procedure.

Amputee Adapters (TR Series and YR Series)

Amputee adapters serve to relocate the camber tube behind the rear of the wheelchair. By positioning the camber tube behind the rear of the chair, the center of gravity is shifted rearward and the stability of the chair is increased. Figures 88 through 90 show the configuration of the TR and YR Series wheelchairs when amputee adapters are used.

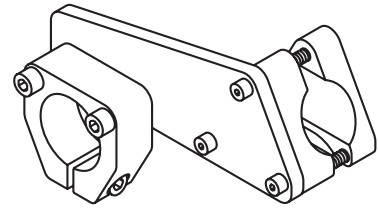

Amputee Axle Plate TR/YR

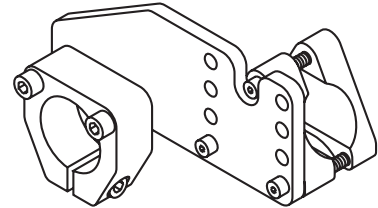

Amputee Axle Plate TR/YR

Figure 88
Amputee Axle Plates

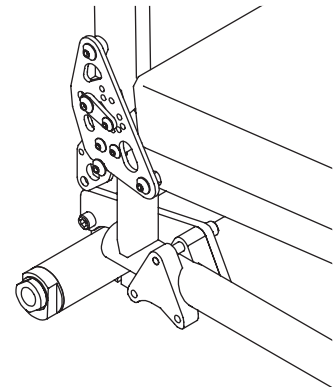

Figure 89
TR/YR Amputee Adapter

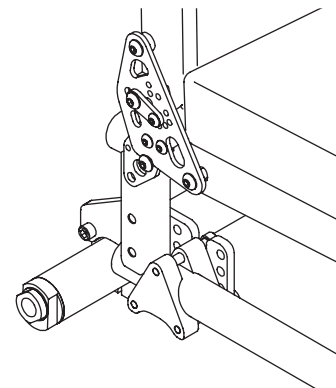

Figure 90
TRA/YRA Amputee Adapter

CHAPTER 10: WHEEL LOCKS

WARNING

TiLite recommends that you remove the wheel locks (whether Standard Push to Lock, Uni-Lock or Scissor Lock) from your chair frame prior to engaging in any contact sport. *If you ignore this Warning, you may seriously injure yourself or others or damage the wheelchair.*

WARNING

If the wheel locks (whether Standard Push to Lock, Uni-Lock or Scissor Lock) are improperly adjusted so the wheel stop embeds less than 3/16" into the tire, the chair may roll unexpectedly. Therefore, before adjusting the lock you must make sure the tires are properly inflated to the recommended tire pressure (see sidewall of the tire). If you adjust the locks when the tires are under-inflated, the lock will not operate properly when the tire is fully inflated. *If you ignore this Warning, you may fall, tip over or lose control of the wheelchair and seriously injure yourself or others or damage the wheelchair.*

WARNING

After making any adjustment to the wheel locks (whether Standard Push to Lock, Uni-Lock or Scissor Lock), engage the wheel locks and push against the tires to verify that the new position permits the wheel locks to fully prevent the wheels from moving. If not, readjust the wheel locks until the wheel locks securely prevent the chair from rolling. *If you ignore this Warning, you may fall, tip over or lose control of the wheelchair and seriously injure yourself or others or damage the wheelchair.*

Standard Push to Lock

(TR Series, YG Series, YR Series, ZR Series, Aero Z and Evo)

Adjusting the Push to Lock Wheel Lock

Tools Needed:

- 3/16" Allen Wrench

1. Loosen the Allen Screws in the wheel lock clamp. See Figure 91.
2. Adjust the position of the wheel lock clamp on the frame so the wheel stop embeds at least 3/16" into the tire when engaged in the locked position.
3. Securely tighten the two Allen Screws that secure the wheel lock clamp to the frame.

Replacing the Push to Lock Wheel Lock

Tools Needed:

- 3/16" Allen Wrench

1. Loosen the two Allen Screws that secure the wheel lock clamp to the frame.

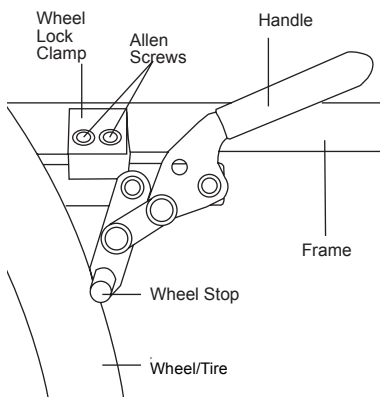

Figure 91
Adjusting/Replacing Standard Push to Lock
Wheel Lock

- Slide the old Standard Push to Lock wheel lock out of the clamp. See Figure 91.
- Slide the new wheel lock into the wheel lock clamp, but do not tighten the Allen Screws.
- Follow the procedures under “Adjusting the Push to Lock Wheel Lock” on page 71 to position and secure the new wheel lock.

Uni-Lock

(TR Series, YG Series, YR Series, ZR Series, Aero Z and Evo)

Adjusting the Uni-Lock Wheel Lock

Tools Needed:

- 3/16" Allen Wrench

- Loosen the two Allen Screws in the wheel lock clamp. See Figure 92.
- Adjust the position of the wheel lock clamp on the frame so the wheel stop embeds at least 3/16" into the tire when engaged in the locked position.
- Securely tighten the two Allen Screws that secure the wheel lock clamp to the frame.

Replacing the Uni-Lock Wheel Lock

Tools Needed:

- 3/16" Allen Wrench

- Loosen the two Allen Screws that secure the wheel lock clamp to the frame.
- Slide the old Uni-Lock out of the clamp. See Figure 92.
- Slide the new Uni-Lock into the wheel lock clamp, but do not tighten the Allen Screws.
- Follow the procedures under “Adjusting the Uni-Lock Wheel Lock” on page 72 to position and secure the new wheel lock.

Changing the Uni-Lock From the Push to the Pull Position

Tools Needed:

- 5/32" Allen Wrench

The Uni-Lock wheel lock can be set up so that you either pull the handle to engage the lock or push the handle to engage the lock. To determine which setup you have, locate the small socket head cap screw in the wheel lock handle base. If it is in the upper position (see Figure 93), the Uni-Lock is set to the “Pull to Lock” position. If it is in the lower position (see Figure 94), the Uni-Lock is set to the “Push to Lock” position. You can change the operation from pull to push or vice versa as follows:

- Remove the socket head cap screw and reposition it to either the Pull to Lock or Push to Lock position, as desired. See Figure 95.
- Securely tighten the socket head cap screw.

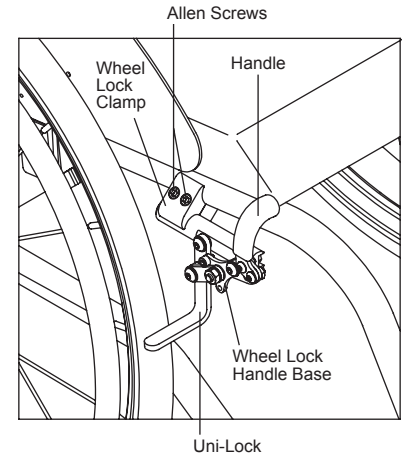

Figure 92
Adjusting/Replacing Uni-Lock Wheel Lock

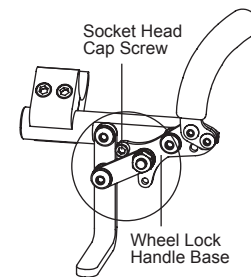

Figure 93
Pull to Lock Position

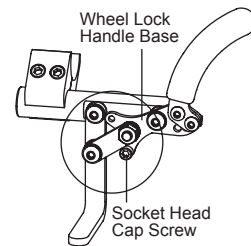

Figure 94
Push to Lock Position

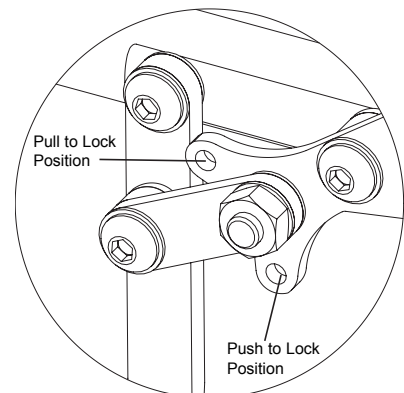

Figure 95
Repositioning the Handle

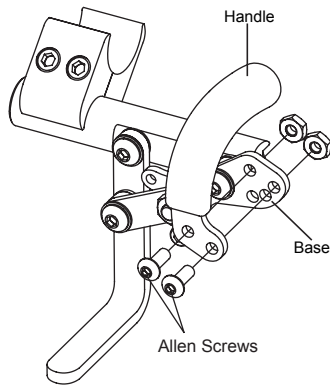

Figure 96
Removing the Wheel Lock Handle

Repositioning The Handle For Your Uni-Lock Wheel Lock

Six (6) handle positions are achievable using the Uni-Lock. See Figures 97 through 100. Each handle position can be used as either a Pull to Lock or a Push to Lock (see “Changing the Uni-Lock From the Push to the Pull Position” on page 72), resulting in 12 possible Uni-Lock setups.

Figures 97 through 100 show the handle in both the engaged (locked) and disengaged (unlocked) positions. Study the Figures to determine which handle configuration will work best for you. Follow the directions below to reconfigure your handle to the desired configuration.

Standard Handle Positions 1, 2, 3

Your Uni-Lock is shipped by TiLite with the handle in standard position 3. If you desire to switch to standard positions 1 or 2, follow the procedures below.

Tools Needed:

- 1/8" Allen Wrench
- 3/8" Open End Wrench

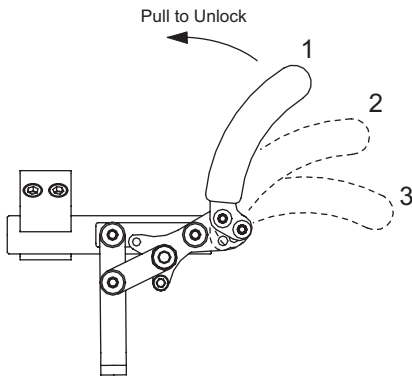

Figure 97
Standard Handle Positions 1, 2 and 3 Locked

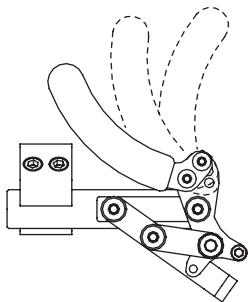

Figure 98
Standard Handle Positions 1, 2 and 3 Unlocked

1. As shown in Figure 96, the wheel lock handle attaches to the wheel lock handle base with two Allen Screws. There is only one hole in the wheel lock handle base through which to attach the upper Allen Screw. There are three holes in the wheel lock handle base through which to attach the lower Allen Screw.
2. Remove the lower Allen Screw and nut that secure the wheel lock handle to the wheel lock handle base.
3. Loosen, but do not remove, the upper Allen Screw that secures the wheel lock handle to the wheel lock handle base.
4. Reposition the wheel lock handle to the desired Standard Handle Position 1, 2 or 3 (see Figures 97 and 98) and replace the Allen Screw and nut.
5. Securely tighten both Allen Screws and nuts.

Reversed Handle Positions 1, 2, 3

You can achieve three additional wheel lock handle positions for your Uni-Lock by reversing the wheel lock handles from the right and left Uni-Locks. To do this, follow the procedures below.

Tools Needed:

- 1/8" Allen Wrench
- 3/8" Open End Wrench

1. Remove the two Allen Screws and nuts that secure the wheel lock handle to the wheel lock handle base on both the right and left Uni-Locks. See Figure 96.
2. Position the wheel lock handle from the left Uni-Lock on the right Uni-Lock in the desired position.
3. Reinstall the two Allen Screws and nuts that secure the wheel lock handle to the wheel lock handle base.
4. Repeat steps 2 and 3 with the wheel lock handle from the right Uni-Lock and the left Uni-Lock.
5. Securely tighten all screws and nuts.

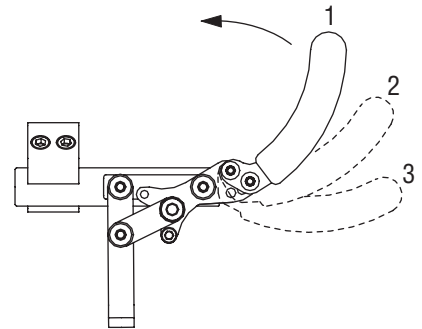

Figure 99
Reversed Handle Positions 1, 2 and 3 Locked

Uni-Lock with Extension Handles

(TR Series, YG Series, YR Series, ZR Series, Aero Z and Evo)

All of the adjustments set forth under "Uni-Lock" on pages 72-74 apply to the Uni-Lock with Extension Handles.

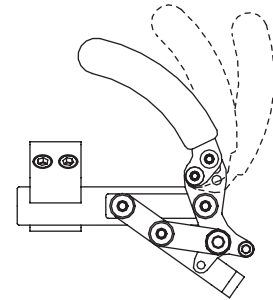

Figure 100
Reversed Handle Positions 1, 2 and 3 Unlocked

Composite Scissor Lock

(TR Series, YG Series, YR Series, ZR Series, Aero Z and Evo)

Adjusting the Composite Scissor Lock

Tools Needed:

- 3/16" Allen Wrench

1. Loosen the two Allen Screws in the wheel lock clamp. See Figure 101.
2. Adjust the position of the wheel lock clamp on the frame so the wheel stop embeds at least 3/16" into the tire when engaged in the locked position.
3. Securely tighten the two Allen Screws that secure the wheel lock clamp to the frame.

Replacing the Composite Scissor Lock

Tools Needed:

- 3/16" Allen Wrench

1. Loosen the two Allen Screws that secure the wheel lock clamp to the frame. See Figure 101.
2. Slide the old composite scissor lock out of the clamp.
3. Slide the new composite scissor lock into the wheel lock clamp, but do not tighten the two Allen Screws.

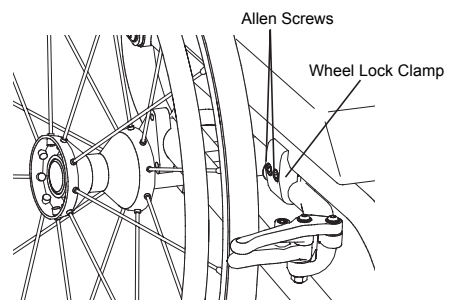

Figure 101
Adjusting/Replacing the Composite Scissorlock

4. Follow the procedures under “Composite Scissor Lock - Adjusting the Composite Scissor Lock” on page 74 to position and secure the new composite scissor lock.

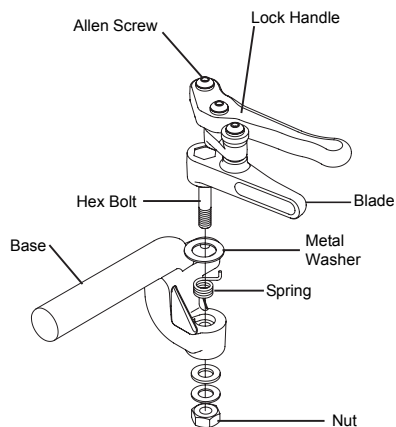

Figure 102
Removing the Scissor Lock Spring

Removing the Scissor Lock Spring

⚠ WARNING

The spring will likely pop out when the two parts are separated, so eye protection is required.

Tools Needed:

- 1/8" Allen Wrench
- 7/16" Open End Wrench

Some wheelchair users may not have sufficient arm strength to comfortably operate the composite scissor lock due to the tension in the spring mechanism. The spring can be removed to facilitate easier operation of the lock. Removal of the spring does not affect the lock's ability to properly secure the rear wheel when fully engaged.

NOTE: Once removed, the spring cannot be readily re-installed without a special installation tool. If you require the re-installation tool, contact TiLite Customer Service at 1-800-545-2266.

To remove the spring:

1. Remove the Allen Screw. See Figure 102. Carefully note the order of the washers on either side of the lock handle. See Figure 103.
2. Remove the nut. See Figure 102. Carefully note the order of the washers between the nut and base.
3. Carefully separate the locking mechanism (handle and blade) portion of the scissor lock from the base.
4. Remove and set aside the spring and metal washer shown in Figure 102.
5. Replace the spring and washer shown in Figure 102 with the black plastic washer that shipped with your wheelchair.
6. Reattach the locking mechanism (handle and blade) portion of the scissor lock to the base by inserting the hex bolt through the black plastic washer (instead of the metal washer and spring), the base, and the two washers and nut removed in Step 2.
7. Loosely secure the nut.
8. Reattach the handle to the base by inserting the Allen Screw removed in Step 1 through the top washer, the handle sleeve, the handle, the two middle washers, the base and the bottom nut. See Figure 103.
9. Securely tighten the Allen Screw.
10. Tighten the nut that was loosely secured in Step 7. Do not over-tighten or the scissor lock will become difficult to operate.
11. Reinstall the scissor lock on the wheelchair and make sure it is properly positioned to fully lock the rear wheel and prevent it from turning when the lock is engaged. See “Adjusting the Composite Scissor Lock” on page 74.

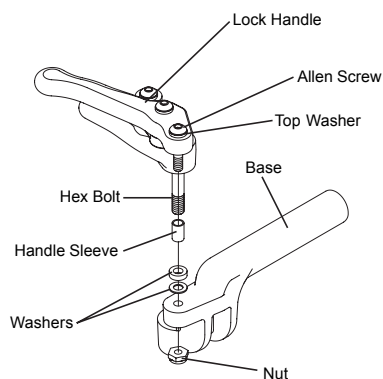

Figure 103
Reassembling the Scissor Lock

CHAPTER 11: CASTERS, FORKS AND CASTER PIN LOCKS

Front Casters and Forks

(YG Series, TRA, YRA, Evo and BB)

⚠ WARNING

Always mount identical size front casters and forks on both sides of your wheelchair. *If you ignore this Warning, you may fall, tip over or lose control of the wheelchair and seriously injure yourself or others or damage the wheelchair.*

Note: The following instructions apply with respect to all 3", 4", 5" and 6" front casters. See Figure 105.

Replacing Front Casters

Tools Needed:

- Two 1/8" Allen Wrenches

1. Remove the two Allen Screws, finish washers and axle that secure the front caster to the fork. **Note:** It will be necessary to use one Allen Wrench to hold one screw in place and a second Allen Wrench to loosen the other screw. See Figure 104.
2. Remove the front caster and fork spacers from the fork.
3. Install the new front caster and fork spacers onto the fork and securely tighten the two Allen Screws. **Note:** It will be necessary to use one Allen Wrench to hold one screw in place in order to be able to securely tighten the other screw with the second Allen Wrench.

⚠ WARNING

The threads on the Allen Screws that secure the front casters to the forks have been treated with a medium strength threadlock to reduce the possibility they will become loose. You should be able to remove and reinstall these Allen Screws two or three times without reapplying threadlock to these screws. If you repeatedly remove and reinstall these Allen Screws, TiLite requires that you reapply a medium-strength threadlock after every second adjustment.

Replacing Front Fork Assemblies

Tools Needed:

- 5/64" Allen Wrench

Note: TiLite fork stems are installed in TiLite forks using Loctite™. Accordingly, if it becomes necessary to replace your forks or fork stems, TiLite requires that you order the complete front fork assembly.

1. Remove the front casters. See "Replacing Front Casters" on page 76.

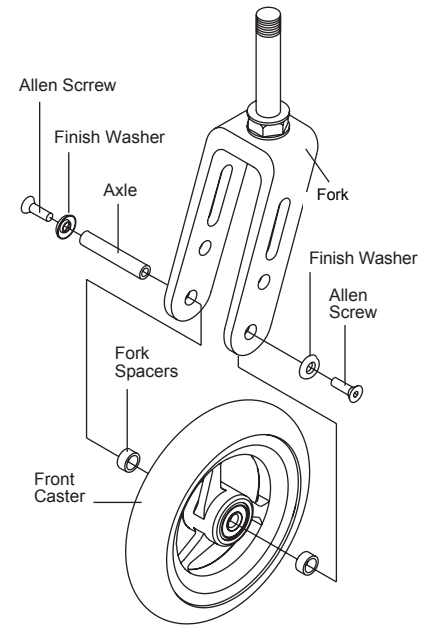

Figure 104
Replacing the Front Casters

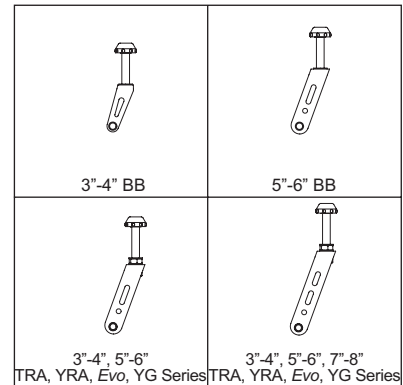

Figure 105
Front Fork Styles

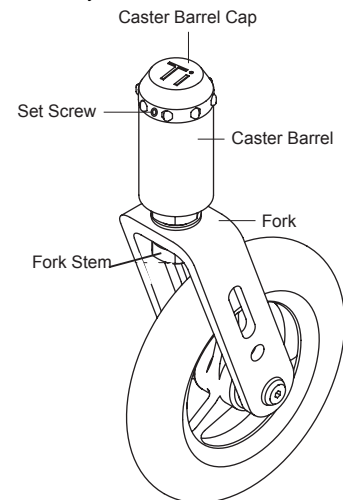

Figure 106
Replacing the Front Fork Assembly

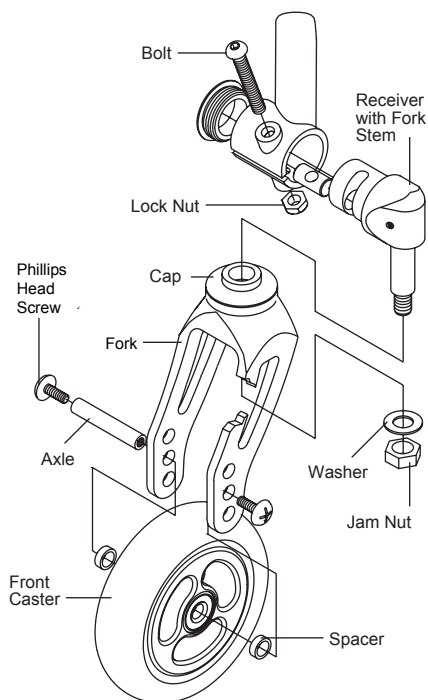

Figure 107
ZRA/Aero Z Forks

2. Loosen the set screw in the caster barrel cap. See Figure 106.
3. Unscrew the caster barrel cap.
4. Remove the front fork assembly (consisting of the fork and the fork stem from the caster barrel.
5. Insert the new fork assembly through the caster barrel and washer and screw the caster barrel cap onto the end of the fork stem.
6. Tighten the set screw in the caster barrel cap.
7. Reinstall the front caster. See "Replacing Front Casters" on page 76.

Front Casters and Forks (ZR Series, Aero Z, TR and YR)

WARNING

Always mount identical size front casters and forks on both sides of your chair. *If you ignore this Warning, you may fall, tip over or lose control of the wheelchair and seriously injure yourself or others or damage the wheelchair.*

Note: The following instructions apply with respect to all 3", 4", 5" and 6" front casters. See Figure 105.

Replacing Front Casters

Tools Needed:

- Two #2 Phillips Head Screw Drivers

1. Remove the two Phillips head screws and axle that secure the front caster to the fork. **Note:** It will be necessary to use one Phillips head screw driver to hold one screw in place and a second screw driver to loosen the other screw. See Figures 107 and 108.
2. Remove the front caster and fork spacers from the fork.
3. Install the new front caster and fork spacers onto the fork and securely tighten the two screws so there is no space between the front caster, the fork spacers and the fork sides. **Note:** It will be necessary to use one Phillips head screw driver to hold one screw in place in order to be able to securely tighten the other screw with the second screw driver.

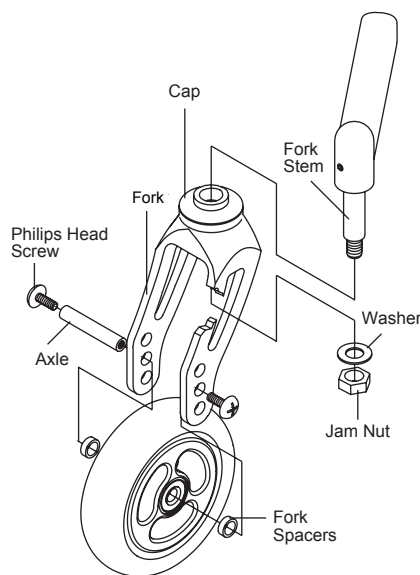

Figure 108
TR/YR/ZR Forks

WARNING

The threads on the screws that secure the front casters to the fork have been treated with a medium strength threadlock to reduce the possibility they will become loose. You should be able to remove and reinstall these screws two or three times without reapplying threadlock to these screws. If you repeatedly remove and reinstall these screws, TiLite requires that you reapply a medium-strength threadlock after every second adjustment.

Replacing Front Forks

Tools Needed:

- 1/2" Socket Wrench

1. Remove the front casters. See "Replacing Front Casters" on page 77.
2. Loosen and remove the jam nut and washer that secures the fork to the fork stem. See Figure 107 (TR, YR and ZR wheelchairs) or Figure 108 (ZRA wheelchairs).
3. Remove the old fork and install the replacement fork on the fork stem.
4. Replace the jam nut and washer and securely tighten.
5. Reinstall the front casters. See "Replacing Front Casters" on page 77.

Adjusting Front Seat Height

Note: Depending on the fork that came with your chair, you may be able to adjust the front seat height of your chair up or down without changing the front casters to a larger or smaller size. Follow the procedures under "Replacing Front Casters" on pages 76 or 77 (depending on your TiLite model) to mount the front casters in the alternative axle holes in the fork. The full range of adjustability will not be available with 5" or 6" front casters. Additional adjustability may be achieved with different forks or casters or with fork stem extensions. Contact TiLite Customer Service at 1-800-545-2266 for assistance.

Caster Pin Locks

(TR Series, YG Series, YR Series, and Evo)

WARNING

ALWAYS be sure to disengage both caster pin locks before attempting to propel your chair. *If you ignore this Warning, you may fall, tip over or lose control of the wheelchair and seriously injure yourself or others or damage the wheelchair.*

To engage the caster pin lock:

1. Rotate the front caster until either notch on the lock ring is directly beneath the pin lock. See Figure 109.
2. Rotate the L-Handle towards the front of the chair until the pin lock snaps down into the locked position.

To disengage the center pin lock:

Lift the L-Handle so the pin lock disengages from the notch in the lock ring and rotate the L-Handle towards rear of the chair.

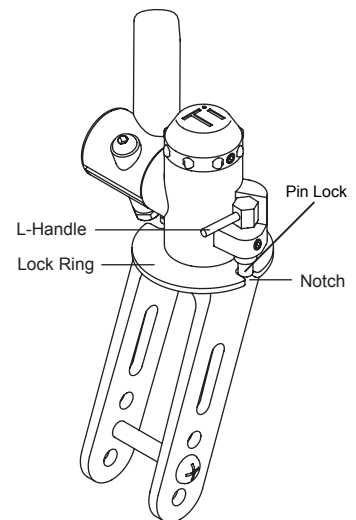

Figure 109
Caster Pin Lock (shown in the locked position)

Adjustable Angle Caster Barrel (YG Series, TRA, YRA and Evo)

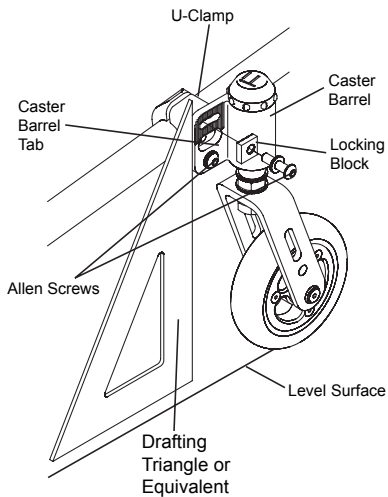

Figure 110
Caster Barrel Angle Adjustment

⚠ WARNING

Always make sure the grooves in the locking block are properly aligned with the grooves in the caster barrel tab. If these grooves are not properly aligned, the grooves may become worn, causing the front caster angle to change unexpectedly. *If you ignore this Warning, you may fall, tip over or lose control of the wheelchair and seriously injure yourself or others or damage the wheelchair.*

Adjusting the Angle

Tools Needed:

- 5/32" Allen Wrench

1. Place the chair on a level surface.
2. Loosen, but do not remove, the two Allen Screws that hold the caster barrel tab in place against the U-Clamp. **Note:** It is necessary to loosen the top screw more than the lower screw in order to permit the locking block to disengage from the caster barrel tab. See Figure 110.
3. Using a drafting triangle or similar 90° angle tool as shown in Figure 110, rotate the caster barrel until the straight edge of the caster barrel tab is perpendicular to the level surface.
4. Securely tighten both Allen Screws, making sure the grooves in the locking block are properly seated in the grooves in the caster barrel tab.
5. After tightening the screws, recheck the caster barrel tab to be certain it is still perpendicular to the ground before riding.

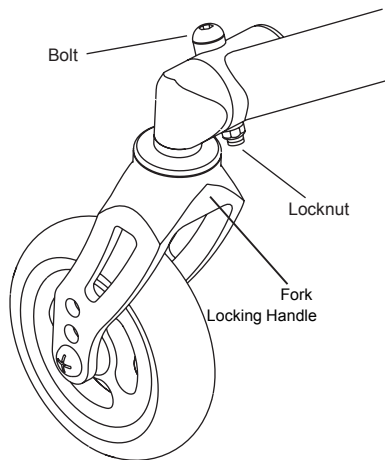

Figure 111
ZRA/Aero Z Angle Adjustable Fork

Angle Adjustable Bearing Fork (ZRA and Aero Z)

Adjusting the Angle

Tools Needed:

- 7/16" Open End Wrench
- 5/32" Allen Wrench

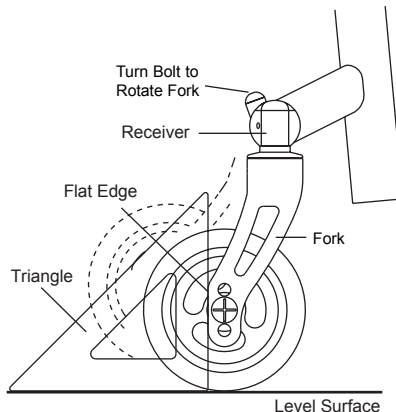

Figure 112
Squaring up the ZRA/Aero Z Angle Adjustable Mounting Fork

1. Place the chair on a level surface.
2. Loosen the locknut while keeping the bolt from rotating. **Note:** It is only necessary to loosen (not remove) the locknut to allow the bolt to be easily turned with an Allen Wrench. See Figure 111.
3. Turn the bolt to adjust the angle of the fork.
4. Using a drafting triangle or similar 90° angle tool as shown in Figure 112, rotate the fork until the flat edge of the fork is perpendicular to the level surface.
5. Using the Allen Wrench to prevent the bolt from turning (and the angle of the fork from changing), use the open end wrench to securely tighten the locknut.
6. After tightening the locknut, recheck the fork to be certain it is still perpendicular to the ground before riding.

Note: If your chair is equipped with Frog Legs®, you must square the receiver to the level surface because the flat edge of the Frog Legs® fork (see Figure 117 on page 82) is not parallel to the receiver.

ZRA and Aero Z Fork Extensions

WARNING

Always use the same number of fork extensions on both sides of your chair. *If you ignore this Warning, you may fall, tip over or lose control of the wheelchair and seriously injure yourself or others or damage the wheelchair.*

Fork extensions are available for ZRA and Aero Z wheelchairs (not ZR wheelchairs). See Figure 113. Because extensions require a longer fork stem and because the fork stems are permanently attached to the receiver, it is necessary to replace both the receiver and the fork stem if you wish to add extensions to raise the front seat height.

Tools Needed:

- 5/32" Allen Wrench

1. Follow the procedure under “Replacing Front Forks” on page 78 to remove the front casters and forks.
2. Completely remove the Allen Screw and locknut that secure the receiver to the frame. See Figure 113.
3. Slide the receiver (and attached fork stem) out of the frame and remove the caster mount dowel.
4. Insert the caster mount dowel into the new receiver (and attached fork stem) and slide it into the frame.
5. Insert the Allen Screw through the frame, making sure it slides through the notch in the receiver and threads into the hole in the caster mount dowel.
6. Finger tighten the locknut.
7. Install the fork extension and fork onto the fork stem.
8. Reinstall the front caster. See “Replacing Front Casters” on page 77.
9. Follow the procedures under “Angle Adjustable Bearing Fork” on page 79 to square front caster.

Floating Casters

(TR Series, YR Series, YG Series, ZR Series, Aero Z, BB and Evo)

Tools needed:

- 3/16" Allen Wrench
- Wood Block (1" Minimum)
- Drafting Triangle
- Ruler

Note: TiLite rigid wheelchairs are designed to be flexible for improved maneuverability and increased ride comfort. However, this flexibility requires that your chair be set up properly. By following these instructions you will be able to properly set up your TiLite rigid wheelchair so it will perform to its greatest potential.

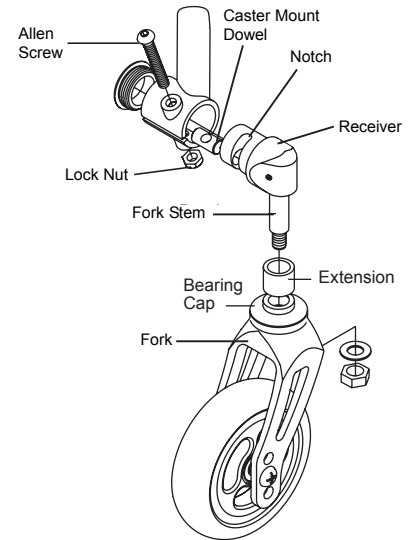

Figure 113
Fork Extensions for ZRA and Aero Z

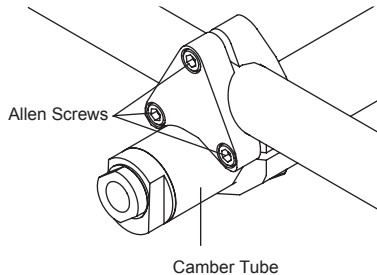

Figure 114
Allen Screws on Camber Clamps

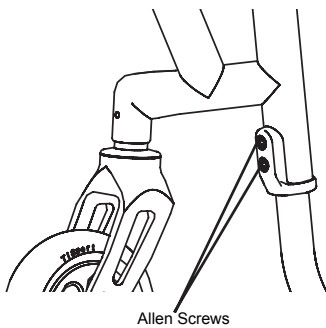

Figure 115
Allen Screws on Footrest Clamp

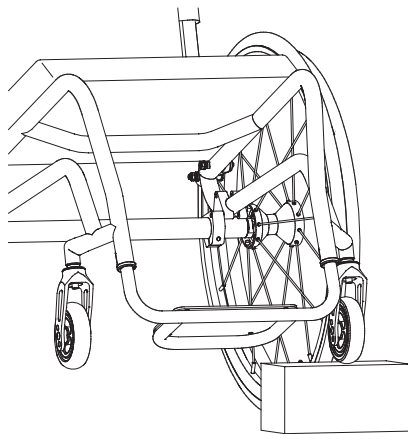

Figure 116
Fixing a Floating Caster

1. Place the wheelchair on a smooth, level surface.
2. Make sure that all tires are properly inflated, that the camber tube is properly centered on the frame side to side, that the camber tube is straight relative to the rear of the frame, that the toe-in/toe-out is correctly set up, and the angle adjustable casters are square to level surface. All of these adjustments are explained elsewhere in this Manual.
3. Loosen, but do not remove, the Allen Screws in the camber tube clamps as shown in Figure 114. **Note:** Figure 114 depicts the camber tube clamps on the TR. If you have a different model, locate the corresponding Allen Screws that secure the camber tube clamp to the frame and the camber tube to the camber tube clamp.
4. Loosen, but do not remove, the Allen Screws in the footrest clamps as shown in Figure 115. **Note:** Figure 115 depicts the footrest clamps on the TR Series. If you have a different model, locate the corresponding screws that secure the footrest assembly to the frame.
5. Make sure your footrest is set to your desired seat-to-footrest measurement, and, using a ruler, make sure the left and right sides of the footrest are the same distance to the level surface.
6. If the above adjustments correct the floater, securely tighten all screws. If not, proceed to steps 7 through 9 below.
7. While applying gentle downward pressure on the top of floating caster barrel, securely tighten the Allen Screw in the footrest clamp on that side of the chair.
8. Securely tighten all Allen Screws on the camber tube clamps, starting with the screws that secure the camber tube to the camber tube clamp (do not start with the screws that secure the clamp to the frame).
9. Check to make sure all of the wheels are flat on your level surface and that neither front caster is "floating". If all wheels are flat and you have no floaters, securely tighten the remaining screws and your set up is complete. If you still have a floating front caster, then continue with steps 10 through 13.
10. Loosen, but do not remove, the Allen Screw on the footrest clamp only on the side of the chair with the floating caster.
11. Place a wood block under the other caster wheel (which is not floating) as shown in Figure 116.
12. Apply gentle downward pressure on the caster wheel that is floating. It is advisable that you have an assistant to place downward pressure on the opposite side of the chair at the backrest when making this adjustment.
13. Remove the wood block and check to see if the caster still floats. If the caster no longer floats, securely tighten the Allen Screw on the footrest clamp. If the caster still floats, or if the other caster starts to float, repeat steps 10 through 12 until the caster no longer floats.

Frog Legs®

(TR Series, YG Series, YR Series, ZR Series, Aero Z and Evo)

Tools Needed:

- 5/32" Allen Wrench

Replacing the Elastomer Shock

1. Remove Allen Screws from hinge and push out the threaded spacer. See Figure 117.
2. Rotate the fork stem section to release the elastomer shock. **Note:** The metal disc is glued to the top of the elastomer shock.
3. Install the new elastomer shock (making sure the metal disc is facing upward toward the fork stem).
4. Push firmly on the fork stem to facilitate reinstalling the Allen Screws and threaded spacers.

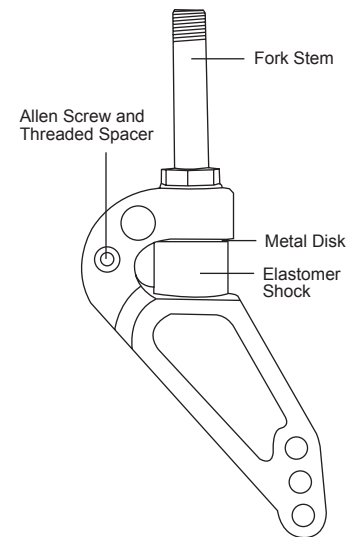

Figure 117
Replacing the Elastomer Shock on Frog Legs®

CHAPTER 12: REAR WHEELS

Rear Wheel with Quick Release Axles (All Models)

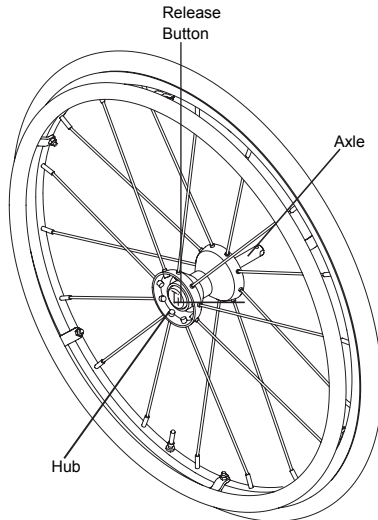

Figure 118
Removing And Replacing The Rear Wheel

⚠ WARNING

Do not attempt these procedures when the chair is occupied. *Serious injury to the occupant will occur.*

Removing

1. Hold wheel securely at the hub through the spokes. See Figure 118.
2. Depress the release button on the quick-release axle and slide the wheel and axle out of the axle sleeve.
3. Release the release button.

Replacing

⚠ WARNING

Make sure the locking balls of the quick-release axle are fully secured inside the axle sleeve before operating the chair. *If you ignore this Warning, you may fall, tip over or lose control of the wheelchair and seriously injure yourself or others or damage the wheelchair.*

1. Hold wheel securely at the hub through the spokes. See Figure 118.
2. Depress the release button on the quick-release axle, making sure the locking balls recess into the axle.
3. Insert the axle all the way into the axle sleeve.
4. Release the release button.
5. Make sure the wheel is securely locked in place by pulling firmly on the wheel without depressing the release button.

Rear Wheel With Quad Release Axle

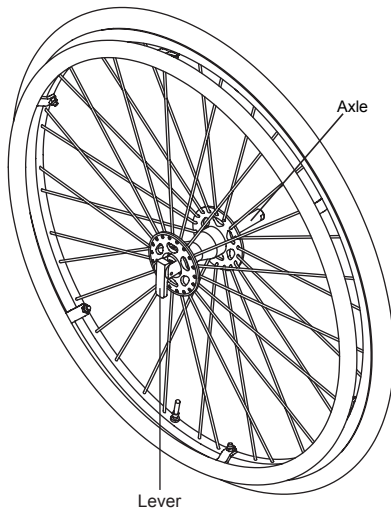

Figure 119
Removing And Replacing The Rear Wheel With Quad Release Axle

⚠ WARNING

Do not attempt these procedures when the chair is occupied. *Serious injury to the occupant will occur.*

Removing

1. Unlock the lever on the quad release axle. See Figure 119.
2. Slide wheel and axle out of the axle sleeve.

Replacing

WARNING

Make sure the locking balls of the quad release axle are fully secured inside the axle sleeve before operating the chair. *If you ignore this Warning, you may fall, tip over or lose control of the wheelchair and seriously injure yourself or others or damage the wheelchair.*

1. Unlock lever on quad release axle. See Figure 119.
Note: Make sure the locking balls in the axle are recessed.
2. Insert the axle all the way into axle sleeve.
3. Lock lever on the quad release axle.
4. Make sure the wheel is securely locked in place by pulling firmly on the wheel without unlocking the lever on the quad release axle.

Handrims

WARNING

Do not attempt these procedures when the chair is occupied. *Serious injury to the occupant will occur.*

WARNING

Replacement of the handrim must be performed by an authorized TiLite dealer or qualified technician. *If you ignore this Warning, you may fall, tip over or lose control of the wheelchair and seriously injure yourself or others or damage the wheelchair.*

Replacing the Handrim

Tools required:

- #2 Phillips Screw Driver
- 3/8" Open End Wrench

WARNING

The tire must be fully deflated before any disassembly procedures are performed. Do not re-inflate the tire until all re-assembly is completed. *If you ignore this Warning, you may fall, tip over or lose control of the wheelchair and seriously injure yourself or others or damage the wheelchair.*

1. Remove the rear wheel from the chair.
2. Remove all air from the inner tube. If you have a Schrader valve (see Figure 120), remove valve stem cap and release all of the air from the tube, by pressing down on the pin in the center of the valve stem. If you have a Presta valve (see Figure 121), remove the valve stem cap, unscrew, counter clockwise, the knurled nut on the valve stem and release all of the air from the tube by pressing down on the pin in the center of the valve stem.
3. While carefully holding the tire, inner tube and rim

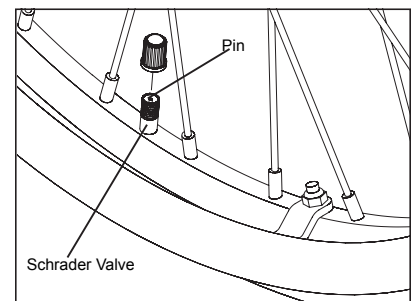

Figure 120
Schrader Valve

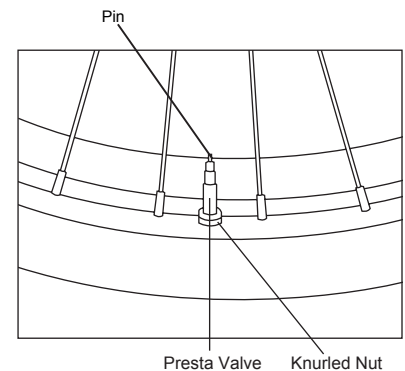

Figure 121
Presta Valve

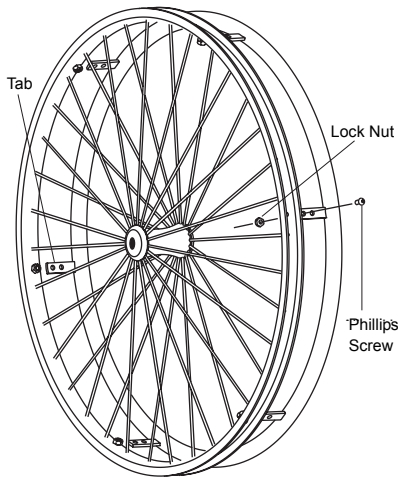

Figure 122
Handrim Replacement

- strip to one side, hold the Phillips Screws with a screw driver and remove the locknuts that secure the handrim tabs to the rear wheel. See Figure 122.
4. Remove the existing handrim.
 5. Install the new handrim by reversing the procedures in step 3 above. **Note:** Your handrim may have two (2) holes on each tab as shown in Figure 122. If you choose to install the handrim in the position closest to the wheel, cut off the extra length of tab. Otherwise it could catch on your clothing or body.
 6. Make sure the rim strip is properly in place so the screws do not puncture the inner tube. Inflate the tire to the correct PSI Rating on the sidewall of the tire.
 7. Reinstall the rear wheel on the chair.
 8. Repeat the procedure for the opposite rear wheel if necessary.

Rear Wheel Spacers

(TR Series, YG Series, YR Series, ZR Series, Aero Z, BB and Evo)

WARNING

Never use rear wheel spacers with the Adjustable Camber System. *If you ignore this Warning, you may fall, tip over or lose control of the wheelchair and seriously injure yourself or others or damage the wheelchair.*

Adjusting Rear Wheel Spacing

Tools required:

- 7/8" open-ended wrench
- 3/4" open-ended wrench
- Torque Wrench

WARNING

Do not use spacers exceeding a total of 3/4". If more than 3/4" of the axle sleeve is outside of the camber plug, the axle sleeve could disengage from the camber plug while you are using the chair. *If you ignore this Warning, you may fall, tip over or lose control of the wheelchair and seriously injure yourself or others or damage the wheelchair.*

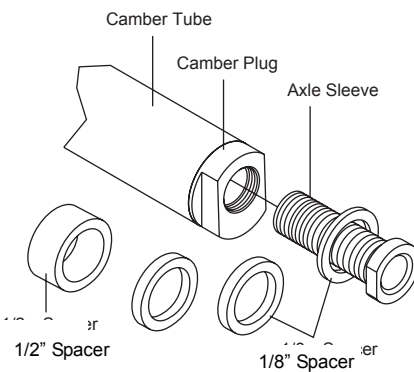

Figure 123
Rear Wheel Spacing

The TiLite TRA and YRA includes a rear wheel spacer package as standard equipment consisting of four 1/8" thick spacers and two 1/2" thick spacers. This package can be selected as an option on the TiLite TR, YR, ZR, Aero Z and ZRA wheelchairs. For other models, contact TiLite Customer Service at 1-800-545-2266.

1. Place the 7/8" open-end wrench onto the camber plug and use the 3/4" open-end wrench to remove the axle sleeve. See Figure 123.
2. Add or delete the spacers you need to increase/decrease your rear wheel spacing.
3. After you have adjusted your rear wheel spacing, reinstall the axle sleeve in the camber plug and hand tighten.
4. Using a torque wrench, tighten the axle sleeve to 230 inch-pounds.

CHAPTER 13: ANTI-TIPS

Rear Anti-Tips

(TR Series, YG Series, YR Series, BB, Evo, ZRA and Aero Z)

Adjusting

1. To adjust the height of the rear anti-tip, press the two Release Buttons on the telescoping lower tube, then adjust the height of the lower tube so the wheel is within 1-1/2" to 2" off the ground. See Figure 124.
2. To rotate the anti-tips upward, press the release button on the anti-tip receptacle to release the extension tube and rotate upward until the release button locks in place on the opposite side of the anti-tip receptacle.
3. To remove the rear anti-tip, press the release button on the anti-tip receptacle and pull the extension tube out of the anti-tip receptacle.

Note: 1-1/2" to 2" of clearance between the bottom of the anti-tip wheels and the floor must be maintained to ensure proper anti-tip function.

Mounting the Rear Anti-Tip Receptacle (ZRA and Aero Z)

WARNING

Mounting the rear anti-tip receptacle must be performed by an authorized TiLite dealer or qualified technician. *If you ignore this Warning, you may fall, tip over or lose control of the wheelchair and seriously injure yourself or others or damage the wheelchair.*

Note: Unless you ordered rear anti-tips when you originally ordered your TiLite wheelchair, you will need to order replacement Allen Screws when ordering rear anti-tips.

Tools Needed:

- 5/32" Allen Wrench
- 7/16" Open End Wrench

1. Align the two holes in the anti-tip receptacle with the bottom two holes in the camber tube mount and with the anti-tip receiver positioned under the camber tube and facing rearward. See Figure 125.
2. Insert the Allen Screws through the camber tube mount and the anti-tip receptacle.
3. Install the locknuts and securely tighten.

Mounting the Rear Anti-Tip Receptacle (TRA and YRA)

WARNING

Mounting the rear anti-tip receptacle must be performed by an authorized TiLite dealer or qualified technician. *If you ignore this Warning, you may fall, tip over or lose control of the wheelchair and seriously injure yourself or others or damage the wheelchair.*

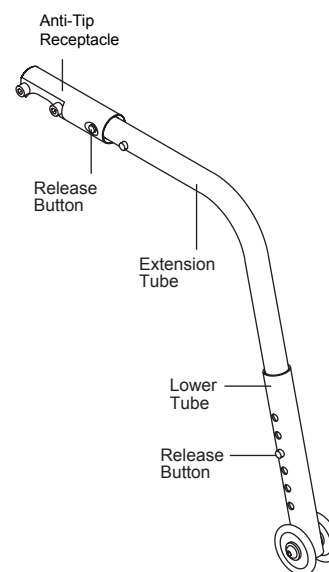

Figure 124
Adjusting the Rear Anti-tip

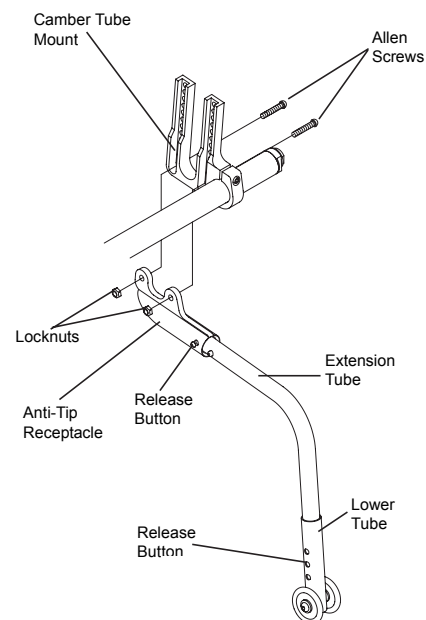

Figure 125
Mounting the rear Anti-Tip Receptacle on the
ZRA and Aero Z

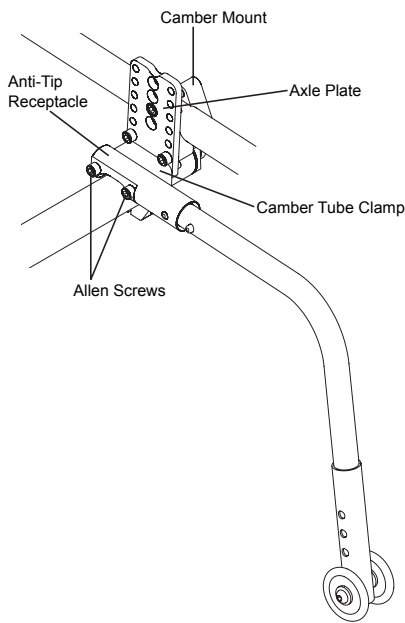

Figure 126
Mounting the rear Anti-Tip Receptacle on the TRA and the YRA

NOTE: Unless you ordered rear anti-tips when you originally ordered your TiLite wheelchair, you will need to order replacement Allen Screws when ordering rear anti-tips.

Tools Needed:

- 3/16" Allen Wrench
- 7/16" Open End Wrench

1. Remove the rear wheels and place the chair frame on a level surface.
2. Remove the Allen Screws that secure the camber tube clamp and the axle plate to the threaded camber mount.
3. Align the two holes in the anti-tip receptacle with the two holes in the camber tube clamp and with the anti-tip receptacle positioned over the camber tube and facing rearward. See Figure 126.
4. Insert the replacement Allen Screws through the anti-tip receptacle, the camber tube clamp, the axle plate and the non-threaded camber mount and into the threaded camber mount.
5. Securely tighten.
6. Reinstall rear wheels.

Mounting the Rear Anti-Tip Receptacle (TR, YR and BB)

⚠ WARNING

Mounting the rear anti-tip receptacle must be performed by an authorized TiLite dealer or qualified technician. *If you ignore this Warning, you may fall, tip over or lose control of the wheelchair and seriously injure yourself or others or damage the wheelchair.*

NOTE: Unless you ordered rear anti-tips when you originally ordered your TiLite wheelchair, you will need to order replacement Allen Screws when ordering rear anti-tips. You will also need to order new camber tube mounts and a camber tube clamp. See Figure 127.

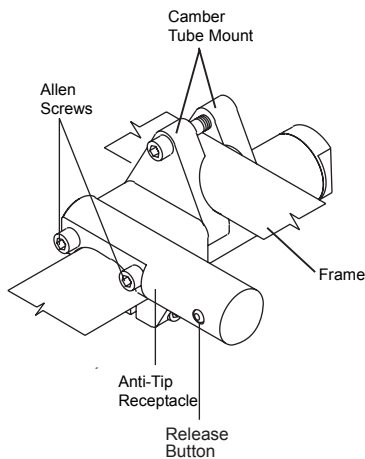

Figure 127
Mounting the Rear Anti-Tip Receptacle on the TR, YR and BB

Tools Needed:

- 3/16" Allen Wrench

1. Remove the rear wheels and place the frame on a level surface.
2. Remove the Allen Screws that secure the camber tube mounts to the frame.
3. Align the two holes in the anti-tip receptacle with the two holes in the camber tube mounts, the camber tube clamp and with the anti-tip receiver positioned over the camber tube and facing rearward. See Figure 127.
4. Insert the replacement Allen Screws through the anti-tip receptacle, the non-threaded camber tube mount and into the threaded camber tube mount.
5. Securely tighten.
6. Reinstall rear wheels.

Mounting the Rear Anti-Tip Receptacle (Evo)

WARNING

Mounting the rear anti-tip receptacle must be performed by an authorized TiLite dealer or qualified technician. *If you ignore this Warning, you may fall, tip over or lose control of the wheelchair and seriously injure yourself or others or damage the wheelchair.*

NOTE: Unless you ordered rear anti-tips when you originally ordered your TiLite wheelchair, you will need to order replacement Allen Screws and axle plate spacers when ordering rear anti-tips.

Tools Needed:

- 5/32" Allen Wrench
- 7/16" Open End Wrench

1. Remove the rear wheels and place the frame on a level surface.
2. Remove all three (3) Allen Screws that secure the adjustable axle plate to the frame. Carefully note the placement of the plate and the order of the various washers and nuts.
3. Install the anti-tip receptacle as shown in Figure 128. Note that the axle plate spacer must be added between the adjustable axle plate and the frame at the forward end of the adjustable axle plate.
4. At the rearward end of the adjustable axle plate, insert the replacement Allen Screw through the washers, the frame, the washers, the anti-tip receptacle, and the adjustable axle plate and securely tighten the locknuts.
5. Install the second Allen Screw through the washers, the frame, the washers, and the anti-tip receptacle and securely tighten the locknuts.
6. At the forward end of the adjustable axle plate, insert the replacement Allen Screw through the washers, the frame, the washers, the spacer and the adjustable axle plate and securely tighten the locknuts.
7. Reinstall the rear wheels.

Mounting the Rear Anti-Tip Receptacle (YG Series)

WARNING

Mounting the rear anti-tip receptacle must be performed by an authorized TiLite dealer or qualified technician. *If you ignore this Warning, you may fall, tip over or lose control of the wheelchair and seriously injure yourself or others or damage the wheelchair.*

NOTE: Unless you ordered rear anti-tips when you originally ordered your TiLite wheelchair, you will need to order replacement Allen Screws when ordering rear anti-tips.

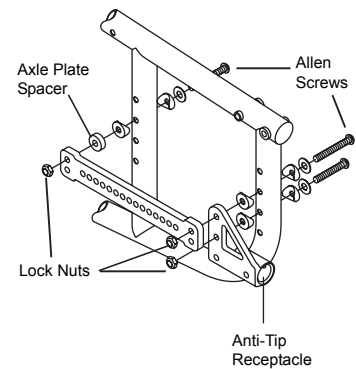

Figure 128
EVO Anti-tip Configuration

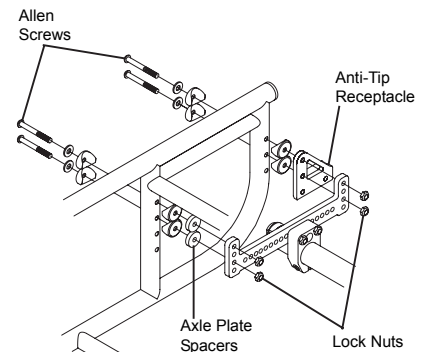

Figure 129
YG Series Anti-tip Configuration

Tools Needed:

- 5/32" Allen Wrench
- 7/16" Open End Wrench

1. Remove the rear wheels and place the frame on a level surface.
2. Remove the two Allen Screws that secure the adjustable axle plate at the rear of the frame. Carefully note the placement of the plate and the order of the various washers and nuts (and, if applicable, stroller handle and/or armrest receivers). See Figure 129.
3. Install the anti-tip receptacle as shown in Figure 129.
4. Insert the replacement Allen Screws through the anti-tip receptacle, the axle plate, the various washers and the locknuts and securely tighten the locknuts.
5. Reinstall the rear wheels.

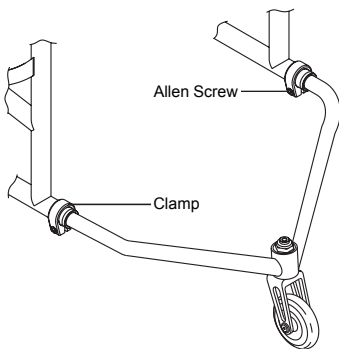

Figure 130
Standard Titanium 5th Wheel Anti-Tip with Swivel Caster Adjustment

Standard Titanium 5th Wheel With Single Swivel Caster (TR, YR and BB)

Adjusting

Tools Needed:

- 3/16" Allen Wrench

1. Loosen the Allen Screws on each clamp. See Figure 130.
2. Adjust the anti-tip forward or backward. Make sure the 5th wheel is centered relative to the frame.
3. Tighten the Allen Screws.

Quick Release Titanium 5th Wheel With Single Swivel Caster (TR, YR and BB)

Adjusting

Tools Needed:

- 5/32" Allen Wrench

1. Lift up on the skewer handles of the quick-release clamps and turn counter-clockwise while holding the skewer nuts in place to permit the 5th wheel to slide in or out of the frame. See Figure 131.
2. Loosen the Allen Screws on the clamp stops on the 3/4" tube.
3. Adjust the anti-tip forward or backward to desired position.
4. Rotate the skewer handle of the quick release clamps clockwise while holding the skewer nut in place and engage the quick release clamps to secure the 5th wheel anti-tip.
5. Slide the clamp stops along the 3/4" tube until they are flush with the frame and tighten the Allen Screws.

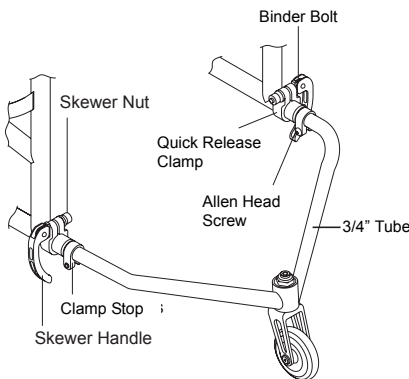

Figure 131
Quick Release Titanium 5th Wheel Anti-Tip With Swivel Caster Adjustment

- The clamp stops serve to mark the position of the 5th wheel so you can quickly remove the 5th wheel and reinstall it later to the precise position.

5th Wheel Swivel Caster

(TR, YR and BB)

Adjusting the Height of the 5th Wheel Swivel Caster

Tools Needed:

- 3/4" End Wrench

- Remove the lock nut. See Figure 132.
- Remove caster wheel assembly.
- To raise the height of the 5th wheel, move spacers from below the caster barrel to above it. To lower the height, reverse this procedure. **Note:** Do not remove spacers or a sloppy caster stem will result.
- Replace lock nut on stem and tighten to achieve desired swivel tension.

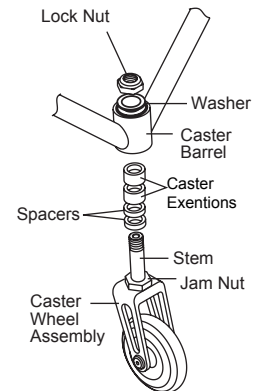

Figure 132
5th Wheel Caster Adjustment

BB Front Wing

(BB)

Adjusting The Front Wing

Tools Required

- 5/32" Allen Wrench
- 3/16" Allen Wrench

- Loosen the two Allen Screws on each frame clamp. See Figure 133.
- Loosen the Allen Screw on each 3/4" binder clamp.
- Adjust the wing forward or backward to desired position.
- Tighten the two Allen Screws on each frame clamp.
- Make sure the wing is not askew to the frame.
- Slide the 3/4" binder clamps toward the frame until they are flush with the frame tube and tighten the Allen Screw on each 3/4" binder clamp. This will enable you to remove the front wing and easily reinstall it in the exact same position at a later time.

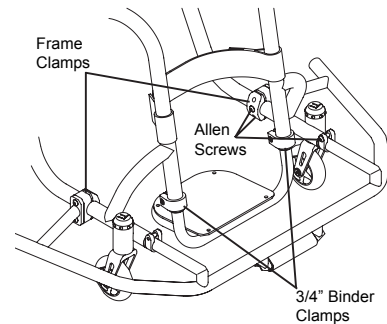

Figure 133
TiSport BB Front Wing Adjustment

Front Anti-Tip

(TR Series, YR Series, ZR Series, Aero Z, BB and Evo)

Removing the Front Anti-Tip

Tools Needed:

- 1/8" Allen Wrench

- Remove the two Allen Screws.
- Remove the front anti-tip assembly.

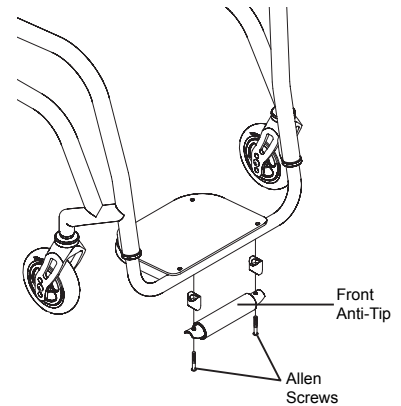

Figure 134
Front Anti-Tip Configuration

CHAPTER 14: YG SERIES ADJUSTABLE SEAT WIDTH AND DEPTH

TiLite YG and YGS wheelchairs are designed to be expandable to accommodate the needs of a growing child. This Chapter explains the procedures to follow in order to expand the seat width and/or depth on these chairs.

Adjusting the Width of the Wheelchair

TiLite YG Series wheelchairs are equipped with three frame expansion brackets and one camber tube expansion bracket. See Figure 135. These brackets enable you to adjust the width of the chair within a 3" range. Additional expansion brackets are available to achieve greater seat widths. In many cases, it may be necessary to purchase a new seat sling and/or back upholstery to accommodate a new seat width.

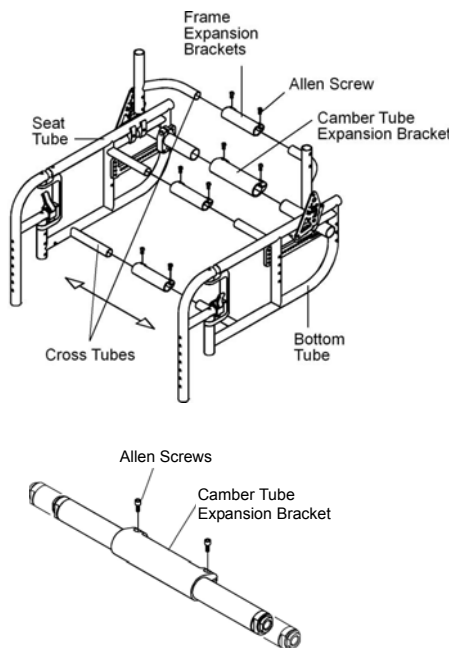

Figure 135
Expanding the Width of the Wheelchair

Tools Needed:

- 3/16" Allen Wrench
- Ruler or measuring tape

1. Remove the rear wheels from the chair.
2. Remove seat cushion and back upholstery. See "Back Upholstery, Seat Upholstery and Seat Cushions" on page 49.
3. Remove seat sling. See "Back Upholstery, Seat Upholstery and Seat Cushions" on page 49.
4. Loosen both Allen Screws on each of the three frame expansion brackets and on the camber tube expansion bracket. See Figure 135.
5. Move side frames in or out to desired chair width.
6. Make sure frame expansion brackets and camber tube expansion bracket are all centered between the two halves of the frame.
7. Make sure at least 1" of each cross tube remains inside each expansion bracket.
8. Loosely secure both Allen Screws on each frame expansion bracket and on the camber tube expansion bracket.
9. Measure the seat width at the front of the frame and at the rear of the frame. Also measure the seat width at the seat tube and the bottom tube. If all seat widths are equal, securely tighten all of the Allen Screws. If any seat widths are unequal, repeat steps 4 through 8 until all seat widths are equal and set at the desired seat width, then securely tighten all of the Allen Screws.
10. Install the seat sling.
11. Install the back upholstery.
12. Replace the seat cushion and reinstall the rear wheels.
13. Check the toe-in/toe-out and adjust as needed and square the front casters.

Adjusting the Seat Depth

Tools Needed:

- 3/16" Allen Wrench
- Ruler or measuring tape

1. Remove the seat cushion and fold down the back of the chair.
2. Loosen, but do not remove, the two Allen Screws that secure the backrest bracket to the frame on both sides of the chair. See Figure 136.
3. Slide the backrest assembly forward or backward to the desired location.
4. Use a ruler to make sure the backrest brackets are positioned in the identical location on both sides of the chair.
5. Securely tighten both Allen Screws on both brackets.

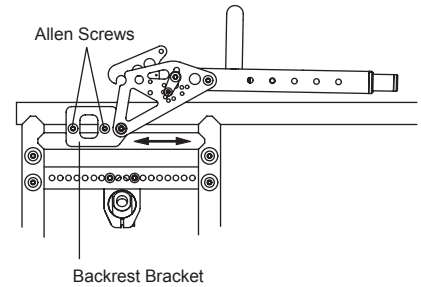

Figure 136
Adjusting the Seat Depth

TILITE LIMITED WARRANTY

A. FRAME – LIFETIME

TiLite warrants the wheelchair frame (including the cross-braces, if any) against defects in materials and workmanship for the lifetime of the original user of the wheelchair. The expected life of the frame is five years.

B. COMPONENTS – ONE (1) YEAR

TiLite warrants all TiLite-made wheelchair components (including, but not limited to, armrest assemblies, backrest assemblies, footrest assemblies, camber tubes and plugs and caster forks) against defects in materials and workmanship for one (1) year from the date of purchase, except as provided below.

C. LIMITATIONS AND EXCLUSIONS

1. This warranty does not cover:
 - a. tires and tubes for front or rear wheels, upholstery (including cushions, seat slings, backrest upholstery and armrest upholstery), or push-handle or stroller handle grips; or
 - b. damage arising from normal wear and tear or from other circumstances beyond TiLite's control; or
 - c. any labor or shipping charges incurred in replacement part installation or repair of this product; or
 - d. TiLite Designs Unlimited frames and frame components, unless TiLite, in its sole discretion, determines that the Designs Unlimited frame or frame component was defectively manufactured.
2. This warranty is VOID if TiLite, in its sole discretion, determines that:
 - a. the original TiLite serial number tag has been removed, altered or defaced; or
 - b. the wheelchair has been subjected to negligence, accident, improper maintenance, storage or operation as required by your TiLite Owners Manual, commercial or institutional use, misuse or abuse, including, but not limited to, exceeding the maximum weight limit of 250 pounds or using the wheelchair with tie downs or locking, clamping or other restraint systems related to the use of the wheelchair in a motor vehicle; or
 - c. the wheelchair has been damaged by improper repairs or repairs made to any component without the express written consent of TiLite; or
 - d. the wheelchair has been modified without TiLite's express written consent, including, but not limited to, modification through the use of unauthorized parts or attachments.
3. This warranty applies only to the original intended user of the wheelchair.

D. OUR RESPONSIBILITY

TiLite's sole responsibility is to repair or replace, in our sole discretion, the covered components of the wheelchair.

E. FOR WARRANTY SERVICE

If your wheelchair requires warranty service, please contact an authorized TiLite Dealer in the USA or an authorized international Distributor. In the event of a defect in material or workmanship, the Dealer or Distributor must obtain a return authorization (RA) number from TiLite, and TiLite issues RA numbers authorizations only to authorized TiLite Dealers and Distributors. If you do not receive satisfactory service, please write to TiLite Customer Service at 1426 E. Third Avenue, Kennewick, WA 99337-9680 or email customerservice@tilite.com. Do not return products to our factory without our prior consent. Returns must be shipped with freight pre-paid, and we recommend that you insure the returned product for its full replacement cost.

F. CONSUMER NOTICE

1. The foregoing express warranty is exclusive and in lieu of all other warranties whatsoever, whether written or oral, express or implied, including the implied warranties of merchantability and fitness for a particular purpose. TiLite shall not be liable for any direct, indirect, consequential or incidental damages whatsoever. By registering your TiLite wheelchair, you will be deemed to agree with all provisions of this warranty.
2. No person is authorized to alter or extend the foregoing express warranty or to waive any of the limitations or exclusions.



tilite.com

P 800.545.2266 | 509.586.6117
F 866.586.2413 | 509.585.8703

1426 East Third Avenue, Kennewick, Washington 99337

A PRODUCT SUPPORTED BY:



usersfirst.org