

scalamobil®

Operator's Manual

GB





The scalamobil S27 is classified as a device type B.

Table of Contents

1	Introduction				
1.1	Delivery Package Standard	6			
1.2	Technical Data	8			
2	Control Elements				
2.1	On/Off Press Switch	9			
2.2	LED Control Lights	9			
2.3	Horizontal Axle	10			
2.4	Rocker Switch	11			
2.5	Connecting Socket for the Charger	12			
2.6	Single Step Switch	12			
2.7	Speed Control	13			
2.8	Compartment for the User's Manual	13			
3	Initial Operation				
3.1	Safety of the Patient	14			
3.2	Safety Instructions	15			
3.3	Performance Check Before Operation	16			
3.4	Mounting to the Wheelchair	18			
3.5	Height Adjustment	20			
3.6	Removal from the Wheelchair	21			
3.7	Removing the Handlebars	23			
3.8	Mounting the Handlebars	23			
4	Operation				
4.1	Upstairs		24		
4.2	Downstairs		27		
4.3	Single Step Switch		29		
4.4	Special Soft Step Function		30		
4.5	Operation on Winding Stairs		30		
5	Care and Maintenance				
5.1	Information on the Battery		32		
5.2	Care		33		
5.3	Maintenance		34		
6	Help in Case of Malfunction				
6.1	What If...		35		
7	Warranty and Liability				
7.1	Warranty		36		
7.2	Liability		36		
8	Global Representatives				40
	Index				

Congratulations,

with the acquisition of the **scalamobil**,

4 you chose a powerful, dependable and multifunctional stairclimbing device of superior technology. With the help of the highly flexible scalamobil you will experience an entirely new dimension of mobility. In this respect you will have great pleasure with the scalamobil, and, appropriately operated, it will soon prove indispensable to you.

Please read the user's manual carefully to get to know the scalamobil and its variety of functions. Some steps of operation may look complicated at first, but you will see that after a free of charge training session by your **alber**-representative the operation will turn out to be effortless and easy.

Your **alber**-representative is going to walk you through each step of operation and will answer all further questions that may arise. In addition, your dealer or the alber representatives listed in chapter 8 will be happy to help you with any problems you might have.

The **alber**-team wishes you a lot of fun with the **scalamobil**.

Please note the following safety instructions!

In the interest of your safety, the scalamobil may only be used by people who:

- have been trained to use the scalamobil appropriately,
- are capable of climbing stairs backwards,
- are capable of lifting at least 20% of their own weight
- are in good physical shape and psychologically stable.

The training session on how to operate the scalamobil properly is part of the delivery package and free of charge. It is done at your convenience by your **alber**-representative or one of the **alber** distributors.

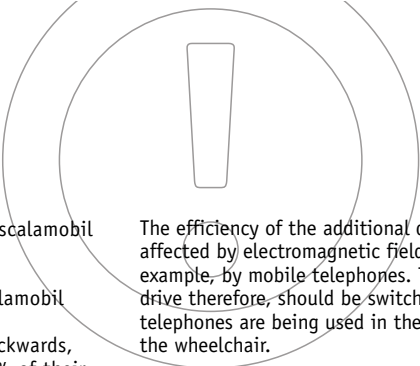

The efficiency of the additional drive may be affected by electromagnetic fields, generated for example, by mobile telephones. The additional drive therefore, should be switched off if mobile telephones are being used in the close vicinity of the wheelchair.

The additional drive can also affect other equipment such as theft-proof cabinets in departmental stores.



Do not use the scalamobil before you participated in the training session.

1.1 Delivery Package

- standard **scalamobil S27**
- **alber**-charger BC 2401
- brief instructions
- user's manual
- upper bolt
- lower bolt

It is standard that the upper bolt [16] and the lower bolt [17] are attached to the scalamobil and already adjusted to the wheelchair by **alber**.

Optional Accessories:

- X6-scalaport
- X3-scala-chair
- X2-scala-chair
- **alber**-charging cable 12V/230V for the vehicle
- headrests
- anti tippers
- safety belt



Your wheelchair must be equipped with special fixtures to attach the scalamobil. If this is not the case, please contact your dealer or one of the **alber-representatives.**

Essential Parts

- 1 Gripping loop
- 2 Rocker switch Up/Down
- 3 On/Off press switch
- 4 LED control light
- 5 Lock for the horizontal axle
- 6 Helix cable plus plug
- 7 Plug
- 8 Adjustment knobs for the height of the handlebars
- 9 Fastening screws for the handlebars
- 10 Electronic unit
- 11 Connecting socket for the charger
- 12 Single step switch
- 13 Speed control
- 14 Compartment for the user's manual
- 15 Housing
- 16 Upper bolts
- 17 Lower bolts
- 18a Outer wheels
- 18b Inner wheels
- 19 Brakes
- 20 Locking pin
- 21 Upper holding device
- 22 Lower holding device
- 23 Soft Step (optional)

1.2 Technical Data

scalamobil S27

Height of the power unit:	445 mm (with the clamping device)
Height of the power unit:	360 mm (without the clamping device)
Width of the power unit:	375 mm
Total height, stowed handlebars:	1140 mm
Total width:	480 mm
Weight with batteries:	26,5 kg
Weight with batteries, without handlebars:	21,7 kg
Load:	120 kg
Voltage:	24 V
Climbing speed:	adjustable, 6-16 steps/minute
Capacity with a fully charged battery:	approximately 300 steps

Technical data - battery

Type of battery:	Sealed lead acid battery
Battery capacity:	3,4 Ah
Battery dimensions:	134 x 67 x 61 mm
Maximum current:	15 A

Technical data - charger

Designation/type:	BC 2401A
Input voltage:	100-240 V
Nominal output voltage:	24 V
Charging current:	1 A
Charging process:	IU0U
Use:	Only in conjunction with the above mentioned battery

All of the scalamobil's electrical components are protected against dampness, humidity, and water splashes.

Due to continuous development, we reserve the right for design changes.



The scalamobil complies to the guidelines for medical products of the European Community 93/42/EWG.

2 Control Elements

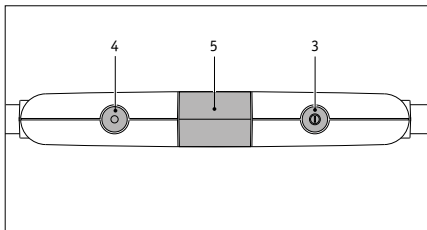

2.1 On/Off Press Switch [3]

When you turn on the scalamobil, the LED control light [4] lights up in green. When you turn it off, the green light extinguishes. If the charger is connected to the scalamobil, the latter cannot be turned on.



If the scalamobil has not been used for more than 5 minutes, it turns itself off automatically in order to spare the battery. At the same time the green LED control light [4] goes out. If you want to continue using the scalamobil at this point, turn the device off and on again.

2.2 LED Control Light [4]

The LED control light continuously indicates the operating state of the scalamobil.

- green - the device is ready to use
- green, flashing - warning! The battery will be empty soon. Finish the started ascent or descent. Do not use the scalamobil any more before the batteries aren't recharged, since the device could possibly stop on the stairs.
- red - warning! The battery is completely empty and must be charged; all of the scalamobil's functions are blocked.



When the LED control light turns red, it indicates general failure. If it goes on after you charged the battery, please contact the alber-service center.

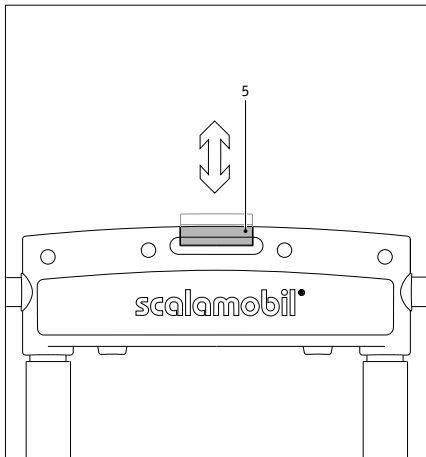

2.3 Lock For the Horizontal Axle [5]

The lock for the horizontal axle is essential for climbing extremely spiral staircases with the scalamobil. The handlebars can be shifted from their regular position either completely to the right or to the left.

- pull the adjustment knob upward to unlock the safety mechanism.
- push the grips in the desired position; the adjustment knob locks automatically.



Before operation, please make sure that the lock has fastened.

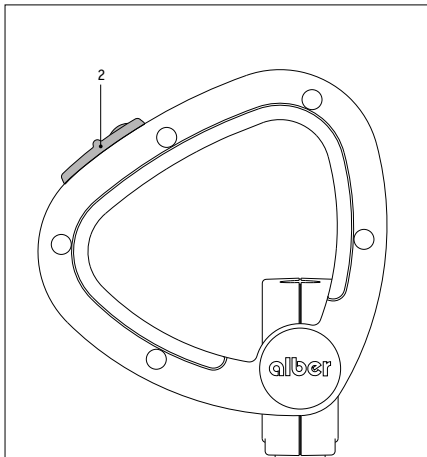

2.4 Rocker Switch [2]

After turning on the scalamobil, you can control the following functions with this switch:

- constant pressure forward -
the device climbs downstairs
- constant pressure backward -
the device climbs upstairs
- releasing the switch -
the device comes to an immediate standstill



If the single step switch is activated (see chapter 2.6), the scalamobil completes one climbing cycle, i.e. it climbs or descends one step, when the rocker switch is pressed.

The wheels stop automatically after one complete rotation. The next climbing cycle begins when you press the rocker switch anew. If the single step switch is not activated, the scalamobil climbs or descends continuously until you release the rocker switch.

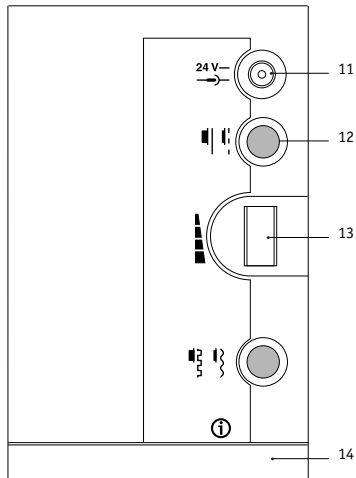

2.5 Connecting Socket For the Charger[11]

Put the plug of the **alber**-charger into this socket. After the battery is fully charged, the charger turns off automatically, so that the battery cannot be overcharged. Therefore, never use another charger.



Please make sure to charge the maintenance-free battery after each use of the scalamobil.

2.6 Single Step Switch [12]

To activate the single step mode you press the single step switch. Read more about this function in chapter 3.

inward position:
single step switch turned on

outward position:
single step switch turned off

2.7

Speed Control [13]

With the speed control you can adjust the climbing speed to your liking. The lowest speed is 6 steps per minute at position 1 of the switch; the highest speed comes to 16 steps per minute at position 6.



New users should avoid the highest speed when they first learn how to operate the scalamobil until they are used to handle the device safely.

2.8

Compartment For the User's Manual [14]

To have the user's manual handy at all times, please always keep it in its compartment [14] on the scalamobil.

3

Initial Operation

3.1

Safety Of the Patient

The first priority while climbing stairs is always the safety and comfort of the patient.

Therefore, please follow the safety instructions listed in chapter 3.2 and the recommendations made in the training session carefully.

In addition, the following situations may arise occasionally:

- in case the patient feels ill while climbing stairs, stop climbing and take care of the patient.
- in case the patient has back problems, reduce the climbing speed. The scalamobil's wheels touch down more softly and the entire climbing process becomes more agreeable to the patient's needs.
- during the climbing process some patients may feel a tension in the neck. In such cases it is advisable to attach an additional headrest to the scalamobil.
- In principle every climbing process has to be completed. However, if the situation arises and you must interrupt the climbing process, lay the scalamobil with the attached wheelchair backwards on the stairs. Due to the safety brakes, it is impossible that the scalamobil rolls over the edge of the step.

3.2

Safety Instructions

- only persons who participated in a training session may operate the scalamobil.
- the scalamobil may only be used with specially adjusted wheelchairs and/or accessories.
- never use the scalamobil inside on wet, slippery, waxed surfaces or on loose rugs or carpets.
- never use the scalamobil outside on wet, slick or icy grounds.
- do not use the scalamobil on steps exceeding a maximum height of 20 cm.
- please wear dry, non-skidding, closed footwear when climbing stairs with the scalamobil.
- never release the handlebars while operating the scalamobil on stairs.
- never touch the turning wheels when you climb stairs or clean the device.

- Make sure that no extraneous particles (e.g. pebbles) get into the power unit or the brakes.



You may never use the scalamobil in the vicinity of inflammable gases.

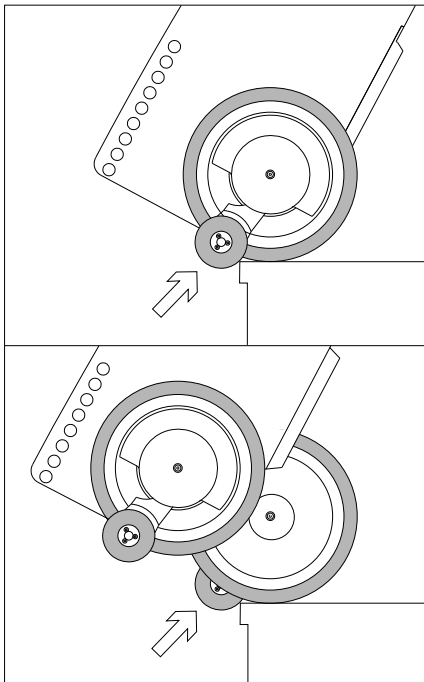

3.3 Performance Check Before Operation

Due to operating safety, you should check the scalamobil's brakes before each use, (the check is done without the wheelchair). Further, you should only use the scalamobil with fully charged batteries

- please check whether the adjustment knobs [8] to adjust the height of the handlebars are tightly fastened.
 - turn on the device as described in chapter 2.1.
 - put the scalamobil on the outer set of wheels by pressing the rocker switch [2], (the single step mode is not activated).
 - push the scalamobil to the edge of the stairs.
- The safety brakes at the outer wheels must lock now; the scalamobil is not supposed to go over the edge of the stairs.
- pull the scalamobil back from the stairs' edge.

- put the scalamobil on the inner set of wheels by pressing the rocker switch [2], (the single step mode is not activated).
- push the scalamobil to the edge of the stairs again.

The safety brakes at the inner wheels must lock now; the scalamobil is not supposed to go over the edge of the stairs.

If all four brakes work correctly, you may attach the scalamobil to the wheelchair as described in chapter 3.3.



In case not all four brakes lock, do not use the scalamobil. Please contact the alber- service center immediately.

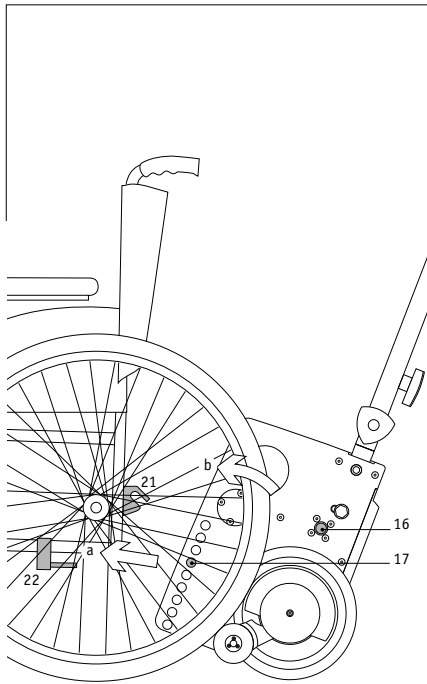

3.4 Mounting to the Wheelchair

In order to mount the scalamobil to your wheelchair, it has to be equipped with a special **alber**-holding device. If this device has not been attached to your wheelchair yet, your dealer, or the **alber**-representative delivering the scalamobil will do so.

- make sure that the wheels of your wheelchair are locked with their brakes so that the wheelchair does not move.
- set the speed control [13] at the lowest climbing speed (position 1).
- align the wheels of the scalamobil in a parallel position by pushing the rocker switch [2].
- move the lower bolts [17] into the lower hooks of the holding device; make sure that the scalamobil is in the middle of the wheelchair.
- now push the rocker switch [2] backward until the upper bolts [16] lock into the forks of the holding device [21].

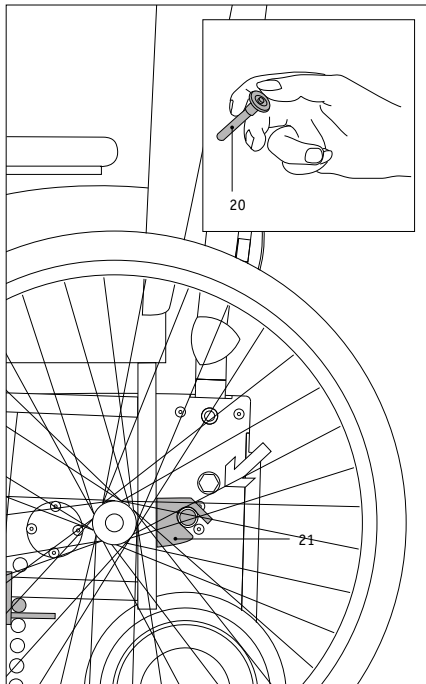

- lock the upper holding device [21] with the locking pin [20]. Unlock the locking pin by pushing in its center with your thumb, then drive the locking pin all the way into the holding device.

In order to begin climbing stairs, you need to unlock the brakes of your wheelchair's back wheels and remove the wheels. See chapter 4 on how to climb stairs.

If you want to continue driving with your wheelchair on level ground, once more align the wheels of the scalamobil in a parallel position by pushing the rocker switch [2]. Then unlock the brakes of the wheelchair. The scalamobil is attached to the wheelchair and ready to use, but it does not hinder the wheelchair's regular operation.



Use only the original alber-locking pins, tested for their safety, to secure the upper holding device.

The alber locking pins are part of the delivery package. If you lose them, never replace the locking pins by nails, screws or the like. Do not touch the wheels of the scalamobil ever when the latter is in operation.

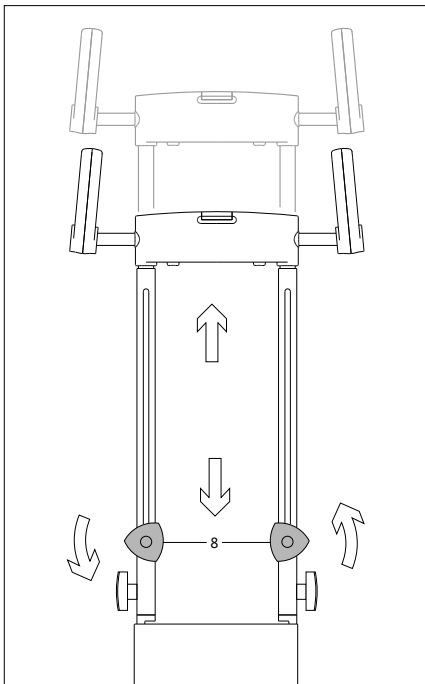

3.5 Height Adjustment Of the Handlebars

In order to use the scalamobil comfortably, the height of the handlebars can be adjusted.

- turn the adjustment knobs [8] approximately one rotation counter clockwise.
- put the handles into the desired position.
- retighten the adjustment knobs [8].



The adjustment range above ground lies between 1.15m and 1.55m. Ideally the grips should be at breast-height of the person operating the scalamobil. Only use the scalamobil with the locking grips tightly fastened.

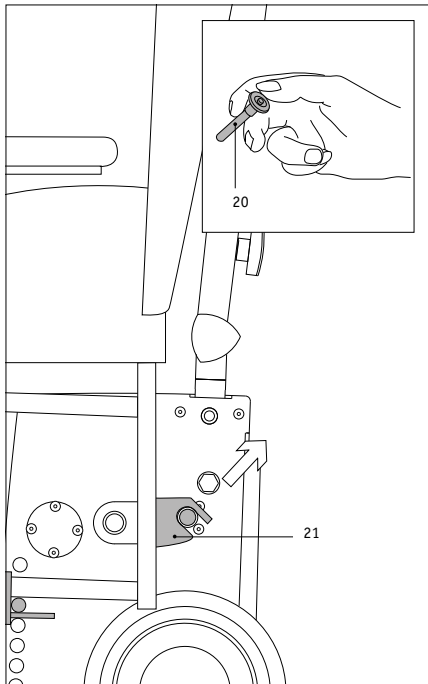

3.6 Removal from the Wheelchair

To remove the scalamobil from the wheelchair you first need to attach its big wheels again.

- turn the speed control [13] to the lowest climbing speed (position 1).
- push the rocker switch [2] backwards until the scalamobil's outer wheels lift the wheelchair.
- insert the wheelchair's wheels into their fittings.
- lock the wheelchair's wheels with its brakes so that the wheelchair cannot be moved.
- Remove the **alber**-locking pins [20] from the forks of the upper holding device [21] by pressing your thumb on the center of the pin while simultaneously taking it out with your middle and index finger.

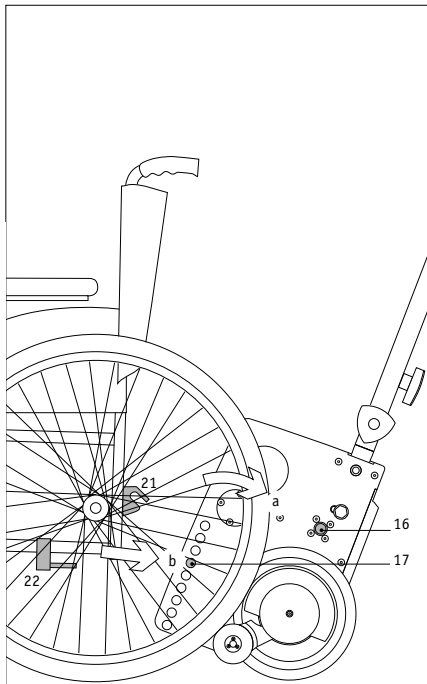

- Align all four wheels of the scalamobil in a parallel position by pushing the rocker switch [2] (the device moves downward and the wheelchair sets down on its wheels).

Remove the scalamobil from underneath the wheelchair.



Please make sure that the wheelchair's wheels are securely locked into their fittings.

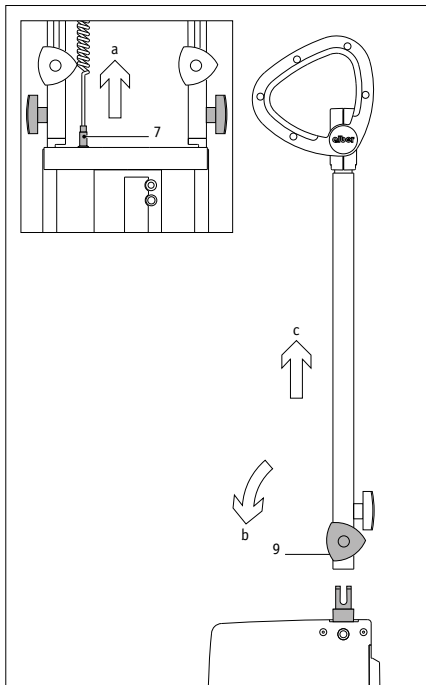

3.7 Removal Of the Handlebars

If necessary, for instance when transporting the scalamobil in your car, the handlebars can be completely removed.

- push the grips together (see chapter 3.5), so that they take up a minimum of space.
- unplug the plug on top of the housing.
- loosen the fastening screws located on the side; turn them until they come loose.
- lift out the entire handlebars.

3.8 Mounting the Handlebars

- push the handlebars into their fixtures.
- screw on the fastening screws [9], and make sure that they are tight.
- put the plug [7] into its socket on top of the housing.
- adjust the height of the handlebars so that the person operating the scalamobil can easily handle the device (see chapter 3.5 height adjustment of the handlebars).

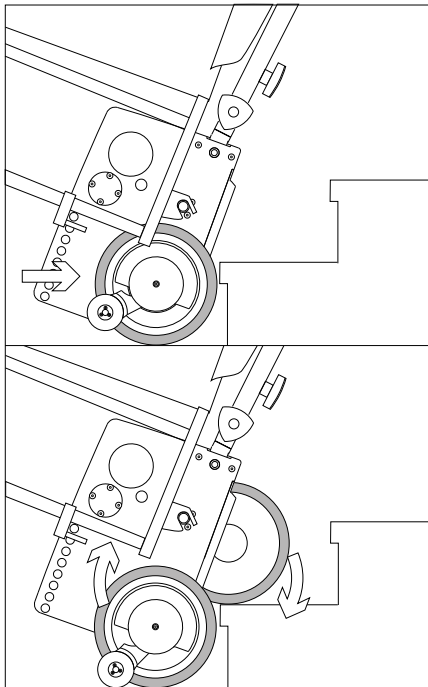

4 Operation

4.1 Upstairs (single step switch is not activated)



Before each climbing process there must be a performance check (see chapter 3.3).

In order to climb stairs, you need to remove the back wheels of your wheelchair. First you attach the scalamobil to your wheelchair as described in chapter 3.4.

Then you do as follows:

- turn on the scalamobil by pressing the On/Off switch.
- align all four wheels of the scalamobil by pressing the rocker switch [2].
- adjust the handlebars to breast height of the person operating the scalamobil (see chapter 3.5).
- tilt the scalamobil plus wheelchair backwards and towards you.

- you have reached an ideal position when you feel hardly any pressure forward or backward accordingly.
- drive the scalamobil backward to the stairway.
- move up two steps above the level of the wheelchair.
- pull the scalamobil against the lowest step.
- push the rocker switch [2] backwards; the scalamobil begins climbing.
(as soon as you release the rocker switch [2], the climbing process is interrupted immediately; the wheels stand still).

The inner pair of wheels touches down on the first step. At the same time the scalamobil with the attached wheelchair is lifted. As soon as all four wheels are in a parallel position once more, the first step has been climbed - the climbing cycle has been completed.

When climbing regular stairs with standard depth, you may push the rocker switch [2] continuously (recommended for skilled

users only) and climb step after step without interruption.

When climbing stairs with an extremely high depth, interrupt the climbing process until you have pulled both pairs of wheels in parallel position to the next step's edge.



During the climbing process always pull the scalamobil towards you. Also the scalamobil plus wheelchair needs to remain in the same tilted, balanced position all the time. Never release the grips of the scalamobil!

25

Once you have reached the top of the stairs, pull the scalamobil plus wheelchair as far back that the wheelchair's front wheels are securely on the floor. In no instance are they to jut out of the step's edge!

The wheels of the scalamobil are now in parallel position. In this combination, scalamobil plus wheelchair, you may cross short distances within your house. However, for further distances or for use outside, we recommend that you attach the wheelchair's big wheels (see chapter 3.6)

When the scalamobil is attached to the wheelchair, the center of gravity of the whole mechanism shifts backward. Thus, before the patient gets out of the wheelchair either remove the scalamobil or by pushing the rocker switch [2] advance the outer wheels [18a] until they touch the floor to function as an additional support.



While you use the scalamobil on stairs you need to make sure that the wheelchair driver sits upright and leans on the wheelchair's back. He further needs to put his feet on the foot rests.

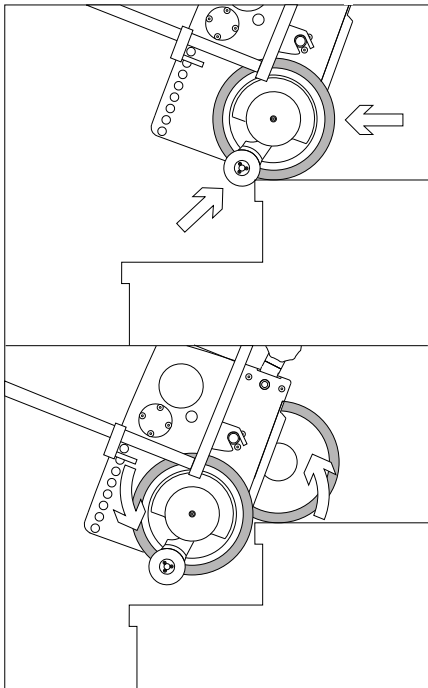

4.2 Downstairs (the single step switch is not activated)



Before each climbing process there must be a performance check (see chapter 3.3)

When you climb downstairs, you also need to remove the wheels of your wheelchair (see chapter 3.4).

Then do as follows:

- turn on the scalamobil by pressing the On/Off switch [3].
- align all four wheels of the scalamobil by pushing the rocker switch [2].
- adjust the handlebars to breast height of the person operating the scalamobil. (also see chapter 3.5).
- tilt the scalamobil with the attached wheelchair toward you and balance it out. You reached an ideal position when you hardly feel any pressure forward or backward accordingly.

- advance slowly to the edge of the stairs until the automatic brakes grip blocking any further advancement.
- push the rocker switch [2] forward; the scalamobil begins to descend the stairs. (If you release the rocker switch [2], the climbing mechanism is interrupted immediately; the wheels come to a standstill).

28

While the inner pair of wheels remains on the upper step, the outer pair of wheels descends to the following step. Simultaneously the scalamobil plus attached wheelchair moves down. As soon as all four wheels are in a parallel position again, you climbed down one step, the climbing cycle has been finished.

When descending regular stairs with standard depth, you may push the rocker switch [2] continuously climbing down step after step without interruption (recommended for skilled users only).

When descending stairs with an extremely high depth, you should interrupt the descending process until you have pushed the pairs of wheels (in parallel position) forward to the edge of the following step.



While descending stairs always push the scalamobil slightly forward, away from you, until the brakes grip on the edge of the following step. Also the scalamobil needs to remain tilted approximately in the same angle. Finally, never release the grips of the scalamobil!

When you reached the end of the stairs, push the scalamobil with the attached wheelchair away from the stairs. The scalamobil's wheels are still in parallel position. In this combination, scalamobil plus wheelchair, you may cross short distances in your house or apartment. However, for further distances, we recommend to remount the wheelchair's big wheels (see chapter 3.6).

When the scalamobil is attached to the wheelchair, the whole mechanism's center of gravity shifts backwards. Thus, before the patient gets out of the wheelchair, either remove the scalamobil or by pushing the rocker switch [2], advance the scalamobil's outer pair of wheels [18a] until they touch the floor and function as an additional support.

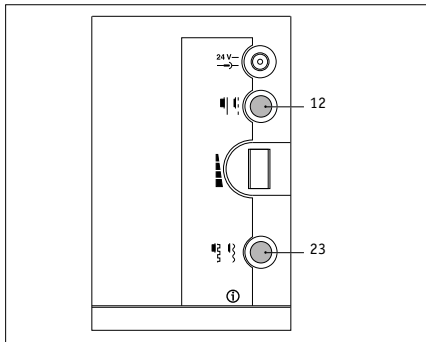

4.3 Climbing Stairs In Single Step Mode

In chapters 4.1 and 4.2 you have been introduced in detail to the individual steps to climb stairs safely. By pushing the rocker switch [2] continuously the scalamobil's wheels begin moving; releasing the switch result in the immediate standstill of the wheels. A continuous use is also possible simply by keeping the rocker switch [2] pressed.

When you activate the single step switch [12], the climbing process is slightly different:

- pushing the rocker switch [2] permanently also results in the rotation of the scalamobil's wheels; however, after one full rotation they automatically come to the correct parallel position, even if you still press the rocker switch [2].
- to continue climbing or descending you need to release the rocker switch [2] and push it continuously once more to initiate the scalamobil's next climbing cycle.

When you need to climb spiral stairs, the single step mode is particularly useful. As stated in chapter 4.5, there it is indispensable to advance the scalamobil's outer wheels to the edge of the following step.

When you activate the single step switch, you automatically prevent an erroneous initiation of the climbing cycle before the scalamobil's wheels are all the way at the edge. Therefore, the climbing and descending becomes even safer for both the person operating the scalamobil and the patient being transported.

For persons unskilled in operating the scalamobil, we recommend to activate the single step switch also for climbing regular stairs.



If you continuously push the rocker switch [2], the wheels complete one rotation. As soon as you release the rocker switch [2] the wheels come to a standstill, even if you keep on pushing the rocker switch [2].

4.4

Special Soft Step Function

If you activate the soft step function by pressing the switch [23], the motor's revolutions per minute decrease just before the wheels touch the following step. Afterwards the motor increases the revolutions per minute again until it reaches the next step.

This process results in a softer touch down on the next step, something the wheelchair driver will notice in the sense that the running process is smoother.



The soft step function can also be activated in single step mode (see chapter 4.3)

4.5

Operation On Winding Stairs

In principle the operation of the scalamobil climbing or descending winding stairs follows the analogous steps described in chapter 4.1 and 4.2. Also the same safety instructions apply. However, we would like to call your attention to the following particular characteristics, since the inside wheels cross a shorter distance than the outside wheels.

4.5.1

Upstairs

- if you have not done so already, turn on the On/Off switch [3].
- advance the scalamobil's four wheels so that they touch the edge of the step.
- push the rocker switch [2] backwards and climb up one step.
- release the rocker switch [2] when all four wheels of the scalamobil are in a parallel position; the climbing process is interrupted.
- advance to the next step by pulling the outer

wheels backward until they touch the edge of the following step.

- begin the next climbing cycle as soon as the brakes grip on the step's edge.

4.5.2 Downstairs

- turn on the scalamobil by pressing the On/Off switch [3].
- advance the scalamobil to the edge of the step so that all four wheels touch the latter.
- push the rocker switch [2] forward and climb down one step.
- release the rocker switch [2] when all four wheels of the scalamobil are in a parallel position; the climbing process is interrupted.
- advance the scalamobil to the next step by pushing the outer wheels forward until they touch the edge of the following step.
- begin the next climbing cycle as soon as the brakes grip on the step's edge.

Recommendation:
since the climbing process must be interrupted on each step, we recommend to activate the single step switch (see chapter 4.3).



If necessary you may shift the handlebars horizontally to gain more space on your left or right side, be it the wall or the handrail (see chapter 2.3).

Care and Maintenance

5.1

Information Concerning the Batteries

The batteries of your scalamobil are maintenance-free and rechargeable. Their durability depends largely on the charging/discharging cycle. For instance, lead batteries are good for more than 1000 partial discharges and for more than 200 discharges of the whole capacity, if a total discharge is avoided. The scalamobil's built-in electronics constantly check the state of the battery thus preventing a total discharge.

- avoid a total discharge of the battery. Recharge your battery after each partial discharge, i.e. after each time you use the scalamobil.
- lead batteries are subject to a so-called self-discharge. Therefore, you should connect the battery of the scalamobil, whenever possible, to the alber charger. The alber-automatic charger immediately turns to retaining the charge when the battery is fully charged, i.e. it is, therefore, impossible to overcharge the batteries.

- If you store batteries for a longer period of time without charging them, they lose some of their capacity. However, after charging and discharging them several times, they regain their full capacity.
- Incorrect handling of the battery may result in the leakage of electrolytic liquid.
- This may cause injuries to the skin or damage clothing.
- Should skin or eyes come into contact with the electrolytic liquid, rinse immediately with clear water and consult a doctor.
- Do not expose the battery to fire or burn. This may cause the battery to explode.
- Do not short circuit the battery. A short circuit causes extremely high currents which may damage the battery or the device.

- After expiry of the service life, return the battery to **alber** or the **alber** specialist dealers who will dispose of it correctly.



The scalamobil's batteries can be charged and discharged in any position. They are considered as safe as dry cells and approved for air travel by DOT and IATA.

5.2 Care

5.2.1 Charging the Battery

Your scalamobil uses up energy each time you employ it. If the battery is fully charged, you can climb approximately 300 steps. However, you should never totally discharge your battery because it may be damaged by it. We, therefore, recommend to recharge the battery after each time you use the scalamobil.



To charge the battery only use the **alber-charger included in the delivery package. The **alber** charger automatically switches itself off as soon as the battery is fully charged. Thus, it is impossible to overcharge it. To charge the battery in your car **alber** offers a special voltage converter 12V/230V, which is an optional purchase.**

5.2.2 Cleaning

The outside of the scalamobil's 4 big wheels where the brakes are located must be cleaned regularly with alcohol to ensure the efficient functioning of the brakes.

34 If your scalamobil is in use daily, you need to clean said parts weekly, otherwise once a month is sufficient.

The powered wheels and the brakes are checked during the biannual safety check, and if necessary substituted by new parts. All other components can be cleaned with regular, mild household cleaners.

5.3 Maintenance

Your scalamobil is a low-maintenance device. However, in the interest of your safety, have the scalamobil thoroughly checked every two years, even if there aren't any outward signs of damage or malfunction. For any maintenance work please see your dealer or any **alber**-distributor.

6

Help In Case Of Malfunction

What If...	Solution	Contact...
the brakes do not grip properly during the performance check?	clean the wheels and brake drums with alcohol	
the brakes still do not grip properly after you cleaned them with alcohol	stop using the scalamobil	your alber -representative
the batteries cannot be recharged	this malfunction can only be repaired at Ulrich Alber GmbH	your alber -representative
the LED control light do not	you may use the scalamobil for a short time	your alber -representative
the scalamobil cannot be turned on	remove the charger	
the scalamobil still cannot be turned on, even though the charger has been removed		your alber -representative
On/Off switch or rocker switch are jamming	stop using the scalamobil	your alber -representative
the scalamobil stops working when you are using it on steps	put the scalamobil backward on the stairs. Its automatic safety brakes prevent it from rolling away.	another person to help.you carry the scalamobil step by step up- or downstairs.
The red LED control light is on?	charge the battery	
The red LED control light is still on, although you charged the battery?		your alber -representative

7

Warranty and Liability

7.1

Warranty

There is a 24 month warranty (6 months on batteries) on the scalamobil referring to flaws in material or processing defects. The warranty begins with the date of purchase.

The warranty excludes:

- regular wear and tear on parts
- damage done due to overloading
- damage done due to improper use
- damage by force
- inadmissible changes on the device or the accessory parts

7.2

Liability

The manufacturer Ulrich Alber GmbH + Co. KG is not responsible for the safety of the scalamobil if:

- the scalamobil was used improperly.
- the scalamobil was not checked regularly by authorized dealers or the Ulrich Alber GmbH + Co. KG.
- the scalamobil was not operated in accordance with this user's manual.
- the scalamobil was operated with insufficiently charged batteries.
- repair work and the like was done by unauthorized persons.

- extraneous parts were added or used with the scalamobil.
- parts of the scalamobil were removed.

8

alber-Werksvertretungen

AUS Hercules Stair Climber

Level 1
138 Silverwater Road
AUS-Silverwater NSW 2141
Tel.: 02-97 379 695 Fax: 02-97 379 782

A Mobitec Mobilitätshilfen GmbH

Gewerbepark/Tiefgraben 420
A-5310 Mondsee
Tel.: 06231-55 350 Fax: 06232-55 354

B EUROMOVE sprl

44, chée de Waterloo
B-1640 Rhode St. Genése
Tel.: 02 - 3585986 Fax: 02 - 3585951

CAN DOLOMITE Home Care Produkts Inc.

50 Shields Court
CAN-Markham, ON L3R 9T5
Tel.: 0905-4 795 479 Fax: 0905-4 799 227

CH Alber AG

Kesselstraße 2
CH-8957 Spreitenbach
Tel.: 056 - 4015200 Fax: 056 - 4015201

CZ PATRON Bohemia s.r.o

Ceskolipska 4319
CZ-27601 Melink
Tel.: 0206-630 135 Fax: 0206-630 199

DK NEBA

Baldersbuen 17, Box 220
DK-2640 Hedehusene
Tel.: 046-590 177 Fax: 046-590 197

S, SF Tunbjers AB

Gamla Vägen 73
S-29034 Fjälkinge
Tel.: 044 - 50530 Fax: 044-58188
<http://www.tunbjer.se>

E Sunrise Medical S.L

Polígono Bakiola, 41
E-48498 Arrankudiaga-Vizcaya
Tel.: 09-0214 2434 Fax: 09-4633 3047

F Mobitec S.a.r.L.

Parc du Moulin à Vent
F-69693 Vénissieux
Tel.: 472-785050 Fax: 472-785055

FIN Oy Nikomed Finland Ab

Olarinluoma 16
FIN-02200 Espoo
Tel.: 08-9-5 259 540 Fax: 08-9-5 259 5444

GB Simorg Limited

Unit C, Abbeygate Business Centre
Hitchin Road
Bedfordshire, LU2 OER, GB-Luton
Tel.: 1582-484785 Fax: 1582-484157

GR Helektrokinissi

Pappaflessa Str. 10
GR-Thessaloniki 55133
Tel.: 31-433720 Fax: 31-433730

I Gruppo Plus

Via f. Ili Carli 69
I-50060 Molino del Piano (FI)
Tel.: 055-8364 442 Fax: 055-8364 607

**IL A.T. World
Revolution in Rehabilitation Ltd.**

19, Hamashbir Street
IL-Holon 58210
Tel.: 072-3-5 502 020 Fax: 072-3-5 585 824

J Alber Japan Co., Ltd.

4-1-9, Narihira, Sumida-ku
J-Tokyo 130-0002
Tel.: 3-5619-7251 Fax: 3-5619-7252

N Medema-gruppen AS

Stamveien 6
N-1481 Hagan
Tel.: 0670-64 917 Fax: 0670-64 990

NL Eureva BV

Saturnusstraat 95
NL-2516 AG Den Haag
Tel.: 070-3855 209 Fax: 070-3470 508

TR Medi-Tera

P.K.87, Kavaklidere 06692
TR-Ankara
Tel.: 0312-4 303 871 Fax: 0312-4 303 872

USA Frank Mobility Systems, Inc.

PIIP-ICM Building
1003, International Drive
USA-Oakdale, PA 15071-9226
Tel.: 0724-6957 822 Fax: 0724-6953 710

Index

A		G	
Attaching the handlebars	23	Gripping loop	11
B		H	
Batteries	12,32	Height adjustment	20
Brakes	15	Horizontal axle	10, 30
C		L	
Care	33	LED control lights	9
Charging the battery	32	Liability	35
Cleaning	33	Lock for the horizontal axle	10
Compartment for the user's manual	13	Locking grips for the handlebars	23
Connecting socket for the charger	12	Lower bolts	18, 21
Control elements	9	M	
D		Maintenance	33
Dealer	38	Malfunction	24
Delivery package	6	Mounting to the wheelchair	18
Downstairs	27	O	
E		On/Off press switch	9
Electronic unit	12	Operation	14
F		Optional Accessories	6
Fastening screws for the height adjustment	20	P	
		Performance check	15
		Plug	23

