



AN ORGANIC EXPERIENCE.

The C400 Corpus® combines innovative design, styling and advanced engineering concepts. The C400 maintains a small profile but combines better indoor maneuverability with superior outdoor performance. The Corpus seating system of the C400 is modular in design, allowing for growth and added seat functions. Ergonomically pleasing with power tilt and recline, customization of the Corpus is almost limitless... an important feature when you are becoming one with nature.

C400
CORPUS

EXPORT

permobil

THE POWER OF MOBILITY

POWER FUNCTIONS



SHROUD COLORS



Power adjustable tilt, seat height, legrests and recline.



Co-pilot: Easy to use, power assisted attendant control. (Option)



Magic Drive: Opens up a world of alternative control possibilities. (Option)



ESP (Enhanced Steering Performance) virtually eliminates the need for constant manual correction when driving on uneven ground, soft surfaces, angled and sloped areas or at high speeds.



UniTrack: Complete and flexible support system. (Option)

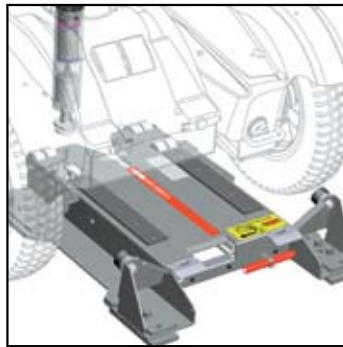

Permolock C: Lock your Permobil into position for safer travel by car. (Option)



R-Net (Standard). Alternative Drive Controls available. (Option)

C400 CORPUS™ SPECIFICATIONS

Weight incl. Batteries	155 kg (342 lbs)	Seat elevator (option)**	200 mm max. (8")	Max Speed	7,5 km/h (4.7 mph)
Base length	1085 mm (43")	Power tilt angle (option)***	45° max. (EU=30°)	Driving speed tilted	½ speed at 135° backrest angle
Base width	620 mm (24")	Power recline (option)	150° max	Range	30–35 km (18–22 miles)
Turning radius	665 mm (26")	Seat Widths	430/480 mm (17"/19")	Battery Capacity	2 x 73 Ah
Seat to floor height*	520 mm (21")	Seat Depths	360–560 mm (16"–22")	Max. user weight	136 kg (300 lbs) (EU 120 kg / 265 lbs)
		Backrest heights	535/605 mm (21"/24")		

* Lowrider 460mm (18")

** Lowrider 150mm (6")

*** Lowrider 20°



THE POWER OF MOBILITY

Permobil AB, Box 120, SE 861 23 Timrå, Sweden. Phone: +46 60 59 59 00.

www.permobil.com