

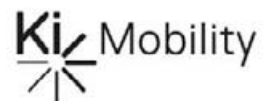

# ROGUE

ROGUE, ROGUE *TTL*

USER INSTRUCTION MANUAL & WARRANTY



Thank you for purchasing a Rogue wheelchair!

Please do not use this wheelchair without first reading this entire manual. BEFORE riding, you should be trained in the safe use of this chair by an Assistive Technology Practitioner (ATP) or clinical professional.



## Table of Contents

I. INTRODUCTION .....	2
II. TABLE OF CONTENTS .....	3
III. NOTICE – READ BEFORE USE.....	4
A. Your Safety and Stability .....	4
IV. WARNINGS .....	4
A. Signal Words .....	4
B. General Warnings .....	5
C. Positioning Belts .....	6
D. Riding Your Wheelchair.....	7
E. Power Drives .....	8
F. Ascending Stairs .....	8
G. Descending Stairs .....	8
H. Transfers .....	9
I. Your Wheelchair and the Environment.....	9
J. Modifying Your Wheelchair.....	10
K. Wheelchair Stability.....	10
V. SET UP AND USE OF YOUR WHEELCHAIR .....	12
A. Your Rogue & Its Parts .....	12
B. Transit Use .....	13
C. Height Adjustable T-Arms .....	16
D. Padded Swing-Away Adjustable Armrests.....	17
E. Armrest Warnings .....	17
F. Center Of Gravity Adjustment .....	18
G. Wheel Camber .....	20
H. Wheelbase Width Adjustment .....	20
I. Setting Toe to Zero .....	21
J. Rear Seat Height Adjustment .....	22
K. Front Seat Height Adjustment.....	22
L. Caster Angle Adjustment.....	23
M. Wheel Installation & Removal.....	24
N. Adjusting the Footrest .....	25
O. Optional Angle Adjustable Footplate .....	25
P. Anti-Tips (Optional) .....	26
Q. Upholstery Fabric.....	27
R. Backrest .....	28
S. Wheel Locks .....	30
T. Seat Sling.....	31
U. Cushion Installation.....	31
VI. MAINTENANCE .....	32
A. Inspecting Your Wheelchair .....	32
1. General Inspections.....	32
B. Cleaning .....	34
1. Axles and Wheels.....	34
2. Upholstery.....	34
C. Storage.....	34
VII. WARRANTY .....	35

## III. NOTICE - READ BEFORE USE

### A. Your Safety and Stability

Ki Mobility manufactures many different wheelchairs that might meet your needs. You should consult an Assistive Technology Professional when selecting which model would best meet your particular requirements and how the wheelchair should be set up and adjusted. Final selection of the type of wheelchair, options and adjustments rests solely with you and your medical professional. The options you choose and the set-up and adjustment of the wheelchair have a direct impact on its stability. Factors to consider that affect your safety and stability are:

- Your personal abilities and capabilities including strength, balance and coordination.
- The types of hazards and obstacles you might encounter during your day.
- The specific dimensions, options and set up. In particular, the seat height, seat depth, seat angle, back angle, size and position of the rear wheels and size and position of the front casters. Any change to any of these items will change the stability of your wheelchair. You should only make changes after consulting with a qualified professional.

## IV. WARNINGS

### A. Signal Words

Within this manual you will find what are referred to as “Signal” words. These words are used to identify and convey the severity of varying hazards. Before using this chair you, and each person who may assist you, should read this entire manual. Please note the Signal word and consider any warnings, cautions or dangers. Make sure to follow all instructions and use your chair safely. The Signal word refers to a hazard or an unsafe practice that may cause severe injury or death to you or to other persons. The “Warnings” are in three main categories, as follows:

**DANGER** – Danger indicates an imminently hazardous situation which, if not avoided, will result in serious injury or death.

**WARNING** – Warning indicates a potentially hazardous situation which, if not avoided, could result in serious injury or death.

**CAUTION** – Caution indicates a potentially hazardous situation which, if not avoided, could result in injury or damage to your wheelchair.

These signal words will be placed throughout the manual, where appropriate, to highlight the hazardous situation. Refer to the following list for hazardous situations that will apply to the general use of this wheelchair.

## IV. WARNINGS

### B. General Warnings

#### **WARNING**

**WARNING:** Do not exceed the weight limit of 275 pounds (350 pounds for heavy duty option) for the Rogue. This is the combined weight of user and all items carried. Exceeding the weight limit can cause damage to your chair or increase the likelihood of a fall or tip back resulting in severe injury or death to the user or others.

#### **DANGER**

**DANGER:** Do not use this chair for weight training. The movement of the additional weight will alter the center of gravity of the wheelchair increasing the likelihood of a tip-over which can cause damage to your chair or cause severe injury or death to the user or others.

#### **WARNING**

**WARNING:** If your wheelchair is equipped with inflatable tires, make sure the tires have been inflated to the correct tire pressure as indicated on the side wall of the tire. Your wheelchair provider can determine if you have inflatable tires. Using your wheelchair without properly inflated tires can have an effect on the stability of the wheelchair causing it to tip over resulting in death or injury to the user or others.

#### **DANGER**

**DANGER:** Do not attempt to push your wheelchair up or down ramps or traverse across a slope of greater than 9 degrees. This is dangerous and increases the likelihood of a fall or tip back resulting in severe injury or death to the user or others.

#### **WARNING**

**WARNING:** Do not attempt to push your wheelchair up an incline that is slick or coated with ice, oil or water. This can cause an unstable situation resulting in death or injury to the user or others.

#### **WARNING**

**WARNING:** Do not lean over the side or back of the wheelchair to extend your reach. This may cause you to fall out of the wheelchair or the wheelchair to tip over resulting in injury or death.

#### **DANGER**

**DANGER:** Do not attempt to lift the wheelchair by holding on to removable parts such as the arms or footrests. Only lift the wheelchair by holding on to the frame. This may cause a fall or loss of control and result in serious injury or death.

#### **CAUTION**

**CAUTION:** Do not over tighten the bolts and hardware that attach various components together on the frame. This could cause serious damage and affect the safety and durability of the wheelchair.

## IV. WARNINGS

### C. Positioning Belts

Positioning belts are designed to assist with proper positioning within the wheelchair. They are not designed as seat belts. Use positioning belts ONLY to help support the user's posture. Misuse of positioning belts may cause severe injury to or death of the user.

- Ensure the user does not slide underneath the positioning belt in the wheelchair seat. If this occurs, the user's breathing may be hampered causing death or serious injury.
- The positioning belt should have a snug fit; tight enough to hold their position, but not so tight as to restrict breathing. You should be able to slide your hand between the positioning belt and the user.
- **NEVER** Use Positioning Belts:
  - a) As a restraint. A restraint requires a doctor's order.
  - b) On a user who is unconscious.
  - c) As a occupant restraint in a motor vehicle. A positioning belt is not designed to replace a seat belt that is attached to the frame of a vehicle, which would be required of an effective seat belt. During a sudden stop, with the force of the stop, the user would be thrown forward. Wheelchair seat belts will not prevent this, and further injury may result from the belts or straps.

#### **DANGER**

**DANGER:** Failure to comply with the instruction above could result in serious injury or death.

## IV. WARNINGS

### D. Riding Your Wheelchair

Your chair is designed for use on solid, flat surfaces such as concrete, asphalt and flooring. Use caution if you push your wheelchair on a wet or slick surface.

#### **WARNING**

**WARNING:** Do not push your chair in sand, loose soil or over rough terrain. This may cause a loss of stability and result in a fall or loss of control and cause serious injury or death.

#### **DANGER**

**DANGER:** In most states, wheelchairs are not legal for use on public roads. If you find you must push on a public road, be alert to the danger of motor vehicles. Use of a wheelchair on a public road can cause serious injury or death.

#### **WARNING**

**WARNING:** Obstacles and road hazards (such as potholes and broken pavement) can damage your chair and may cause a fall, tip-over or loss of control. Failure to comply with this instruction could result in serious injury or death.

#### **DANGER**

**DANGER:** Do not ride your wheelchair on an escalator. Use of a wheelchair on an escalator can cause serious injury or death.

#### To minimize these risks:

- 1) Keep a lookout for danger-scan the area well ahead of your chair as you ride.
- 2) Make sure the floor areas where you live and work are level and free of obstacles.
- 3) Remove or cover threshold strips between rooms.
- 4) Install a ramp at entry or exit doors. Make sure there is not a drop off at the bottom of the ramp.
- 5) To help correct your center of balance:
  - a) Lean your upper body FORWARD slightly as you go UP over an obstacle.
  - b) Press your upper body BACKWARD as you go DOWN from a higher to a lower level.
- 1) If your chair has anti-tip tubes, lock them in place before you go UP over an obstacle.
- 2) Keep both of your hands on the handrims as you go over an obstacle.
- 3) Never push or pull on an object (such as furniture or a doorjamb) to propel your chair.
- 4) Do not operate your wheelchair on roads, streets or highways
- 5) Do not attempt to push over obstacles without assistance.

## IV. WARNINGS

### E. Power Drives

**Ki Mobility does not recommend the installation of power drive systems on any Rogue wheelchair.**

Rogue wheelchairs have not been designed or tested as power wheelchairs. If you add a power drive system to a Rogue wheelchair, be sure the manufacturer of the power drive system has validated and approved the combination of the power drive system and Rogue wheelchair as safe and effective.

#### **WARNING**

**WARNING:** Use of a power drive system that has not been properly validated could result in serious injury or death.

### F. Ascending Stairs

- Have at least two people, who have sufficient strength and skill to handle the weight of the user and wheelchair, assist when trying to go up a set of stairs in this wheelchair.
- Move the wheelchair and user **backwards** up the stairs.
- Position one person behind the user and one person in front of the user. The person in front must hold on to a non-removable part of the wheelchair.
- The rear attendant tilts the chair back and they both lift together. Take one step at a time.
- This may require the anti-tips be flipped up or removed. Make sure the anti-tips are reattached or flipped back down before using the wheelchair.

#### **DANGER**

**DANGER:** Failure to comply with the instructions above could result in serious injury or death.

### G. Descending Stairs

- When descending a set of stairs the user should be facing **forward**.
- A person behind the user, who has sufficient strength and skill to handle the weight of the user and the wheelchair, should tilt the chair backward and let the chair down the stairs one step at a time on the rear wheels.
- This may require that anti tips be flipped up or removed. Make sure the anti-tips are reattached or flipped back down before using the wheelchair.

#### **DANGER**

**DANGER:** Failure to comply with the instructions above could result in serious injury or death.

## IV. WARNINGS

### H. Transfers

A transfer requires good balance and stability. You should receive training from your therapist before attempting to do a transfer on your own.

- Before transferring out of your wheelchair every caution should be taken to reduce the gap between the two surfaces.
- Engage the wheel locks to lock the rear wheels.
- Rotate the casters forward to increase the wheelbase of the wheelchair.
- Remove or swing away the footrests
- Have someone assist you unless you are well experienced in transfers.

It is dangerous to transfer on your own. It requires good balance and agility. Be aware there is a point during every transfer when the wheelchair seat is not below you.



**WARNING:** Failure to perform a transfer properly can result in a fall and can cause severe injury or death.

### I. Your Wheelchair and the Environment

- Your wheelchair is made of many different materials including metal and fabric. Exposure to water or excessive moisture may cause the metal in the wheelchair to rust or corrode and the fabric to tear. Dry your chair as soon as possible if exposed to water.
- DO NOT USE YOUR WHEELCHAIR IN A SHOWER, POOL OR BODY OF WATER. This will cause your wheelchair to rust or corrode and eventually fail.
- Do not operate your wheelchair in sand. Sand can get into the wheel bearings and moving parts. This will cause damage and eventually will cause the wheelchair to fail.
- Make sure any ramp, slope or curb cut you may attempt to ride on is compliant with ADA guidelines. Riding across, up or down any slope that is too great may cause a loss of stability.

ADA Guidelines and more information about accessible design are available at <http://www.ada.gov/>



**WARNING:** Failure to comply with the instructions above may cause a fall or loss of control, which may result in serious injury or death.

## IV. WARNINGS

### J. Modifying your Wheelchair

Your wheelchair was engineered and manufactured under strict design controls. An integral part of this process is ensuring the various components work together correctly; they have been tested to various standards to ensure quality and are approved to work together.

**NO ONE SHOULD MODIFY THIS WHEELCHAIR EXCEPT BY ASSEMBLING APPROVED OPTIONS. THERE ARE NO APPROVED OPTIONS THAT INVOLVE DRILLING OR CUTTING THE FRAME BY ANYONE OTHER THAN A TRAINED KI MOBILITY ASSOCIATE. Contact Ki Mobility or an authorized Ki Mobility supplier before adding any accessories or components not provided by Ki Mobility**



**DANGER:** Failure to comply to these instructions may cause the wheelchair to fail and result in serious injury or death.

### K. Wheelchair Stability

To ensure proper stability, of your wheelchair you must make sure the center of gravity and the wheelchairs base of support is correct for your balance and abilities. Many factors can affect these two elements;

- Seat height
- Size and position of rear wheels
- Seat depth
- Size and position of front casters
- Back angle
- Any seating system components

Generally, the most important factor is the position of the rear wheels for rearward stability. There are other actions than can have an adverse effect on your stability. You should consult with your wheelchair provider and clinicians familiar with your needs and capabilities in determining how this affects your use.



**Moving the rear wheels forward** increases the likelihood of the wheelchair tipping backwards. Make small adjustments and proceed slowly until you learn the new balance point of your wheelchair. **Failure to comply with the instruction above could result in serious injury or death.**



**The farther rearward you place the front casters** the greater the likelihood of the wheelchair tipping forwards. If possible, have your casters mounted forward and, whenever doing a static activity which involves shifting your weight, rotate the casters forward to increase your wheel base. **Failure to comply with this instruction above could result in serious injury or death.**



**Always have a qualified technician** set up your wheelchair with the accessories you plan to use daily.

Changes to how you sit or changes in your weight require your chair to be re-adjusted by a qualified technician. Always use anti-tips while you acclimate to any changes in your chair set up. **Failure to comply with the instruction above could result in serious injury or death.**

## IV. WARNINGS

### K. Wheelchair Stability

#### ⚠️ WARNING ⚠️

**WARNING:** Changes to your Center of Gravity during your daily activities may occur many times a day and change and affect the stability of your wheelchair. You should be aware of these activities and take precautions to minimize the risk of a fall. Failure to comply with the instruction above could result in serious injury or death.

#### ⚠️ WARNING ⚠️

**WARNING:** Dressing in your wheelchair produces movements and momentary positions that can reduce stability. Insure that your anti-tips are in place and rotate your casters forward. Failure to comply with the instruction above could result in serious injury or death.

#### ⚠️ WARNING ⚠️

**WARNING:** Be very careful when reaching for objects if this movement requires you to shift in your seat. This changes your center of gravity. Insure that your anti-tips are in place. Failure to comply with the instruction above could result in serious injury or death.

#### ⚠️ WARNING ⚠️

**WARNING:** Pushing up an incline shifts your center of gravity rearward and can reduce stability. Ensure your anti tips are in place. Failure to comply with the instruction above could result in serious injury or death.

#### ⚠️ WARNING ⚠️

**WARNING:** If attempting a wheelie to get over a curb or obstacle, ensure your anti-tips are in place and lean forward. Do not attempt a wheelie unless you have been trained and always have an attendant behind you to provide assistance if needed. Failure to comply with the instruction above could result in serious injury or death.

#### ⚠️ WARNING ⚠️

**WARNING:** Placing items on the back or front of your wheelchair, such as a backpack or briefcase, alters the balance and center of gravity of the wheelchair. Since the weight of these items can vary greatly at each use do not assume you are accustomed to the balance point. Failure to comply with the instruction above could result in serious injury or death.

**BE AWARE THAT CARRYING HEAVY OBJECTS ON YOUR WHEELCHAIR CAN HAVE AN ADVERSE AFFECT ON THE BALANCE WHICH MAY CAUSE A TIP OVER WHICH MAY RESULT IN SERIOUS INJURY OR DEATH TO THE USER.**

#### ⚠️ WARNING ⚠️

**WARNING:** Insure your anti-tips are in place. You should discuss how you plan to use your wheelchair or any changes you are planning with your clinician. Failure to comply with this instruction may create a potential hazardous situation which, if not avoided, could result in serious injury or death.

## V. SET UP & USE OF YOUR WHEELCHAIR

### A. Your Rogue & Its Parts

- Inspect and maintain this chair strictly per Maintenance Chart in Section VI.
- If you detect a problem, make sure to service or repair the chair before use.
- Have a complete inspection, safety check and service of your chair performed by an authorized supplier annually.

#### ⚠️ WARNING ⚠️

**WARNING:** Failure to read or comply with these instructions may result in damage to your wheelchair, a fall or loss of control causing severe injury to the user or others.



## V. SET UP & USE OF YOUR WHEELCHAIR

### B. Transit Use

It is always safest to transfer out of your wheelchair onto a seat in a motor vehicle with appropriate seat and shoulder belts. **Never use this wheelchair as a seat in a motor vehicle unless it has been equipped with the Transit Option.**

The Rogue Series wheelchair equipped with the Transit Option has been tested to and passed the **RESNA WC-4:2012, Section 19: Wheelchairs used as seats in motor vehicles** and **ISO 7176-19:2008 Wheelchairs -- Part 19: Wheeled mobility devices for use as seats in motor vehicles**. RESNA and ISO standards are designed to test the structural integrity of the wheelchair as a seat for use in a motor vehicle. These standards are also designed to create compatibility with **Wheelchair Tie-down and Occupant Restraint Systems (WTORS)**.

Not all configurations of the Rogue Series wheelchairs are compatible with the Transit Option. Ki Mobility manages the configuration and does not offer the Rogue Series wheelchair except in compatible configurations. If you make changes to your Rogue Series wheelchair after your receive it, you should contact your wheelchair provider or Ki Mobility to make sure it is appropriate to continue to use your wheelchair as a seat in a motor vehicle.

Aftermarket seating may have replaced the original equipment seat and back support designed and tested as part of the Transit Option. Your wheelchair provider should tell you if the seating they provided is original equipment or replacement aftermarket seating. A complete system of wheelchair frame, seating, **Wheelchair Tie-down and Occupant Restraint Systems** and a properly equipped motor vehicle, that have all complied with the standards mentioned in this section, should be in place before using a Rogue Series wheelchair equipped with the Transit Option as a seat in a motor vehicle.

When using your wheelchair as a seat in a motor vehicle you should always observe the following instructions:

- The rider must be in a forward-facing position.
- The rider must not weigh more than 275 lbs.
- Backpacks and pouches should be removed and secured separately in the motor vehicle. In the event of an accident these items can become dangerous projectiles, which may injure or kill you or other occupants of the motor vehicle.
- The rider must use a **Wheelchair Tie-down and Occupant Restraint System** that complies with **RESNA WC-4:2012, Section 18: Wheelchair tie-down and occupant restraint systems for use in motor vehicles or ISO 10542-1:2012 Technical systems and aids for disabled or handicapped persons -- Wheelchair tie-down and occupant-restraint systems -- Part 1: Requirements and test methods for all systems.**

## V. SET UP & USE OF YOUR WHEELCHAIR

### B. Transit Use (Continued)

Fig. 1

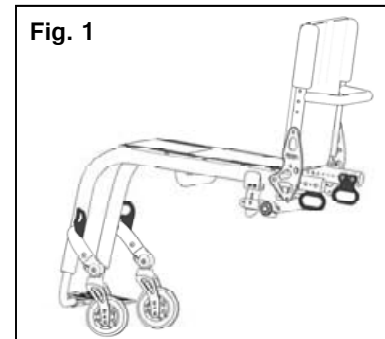

- Attach wheelchair tie-downs to the four securement points (two front, two rear) on the Rogue wheelchair with the Transit Option (Fig. 1) in accordance with the wheelchair tie-down manufacturer's instructions and **RESNA WC-4:2012, Section 18 or ISO 10542-1:2012 - Part 1.**
- Attach occupant restraints in accordance with the occupant restraint manufacturer's instructions and **RESNA WC-4:2012, Section 18 or ISO 10542-1:2012, Part 1.**
- Use of lap belts, chest straps, shoulder harnesses, any other positioning strap system or positioning accessory should not be used, or relied on as an occupant restraint, unless it is marked as such by the manufacturer in accordance with **RESNA WC-4:2012, Section 18 or ISO 10542-1:2012, Part 1.**
- Use of headrests, lateral supports or other positioning accessories should not be used, or relied on as an occupant restraint, unless it is marked as such by the manufacturer in accordance with **RESNA WC-4:2012, Section 18 or ISO 10542-1:2012, Part 1.** or **RESNA WC-4:2012, Section 20: Wheelchair seating systems for use in motor vehicles or ISO 16840-4:2009 Wheelchair seating -- Part 4: Seating systems for use in motor vehicles.**
- After being fitted and adjusted, the top of the original equipment back upholstery should be within 4 inches of the top of your shoulder.
- Any aftermarket seating should be tested to comply with **RESNA WC-4:2012, Section 20 or ISO 16840-4:2009 - Part 4.**
- Attach the seating to the wheelchair frame in accordance with the seating manufacturer's instructions and **RESNA WC-4:2012, Section 20 or ISO 16840-4:2009 - Part 4.**
- Use of lap belts, chest straps, shoulder harnesses, any other positioning strap system or positioning accessory should not be used, or relied on as an occupant restraint, unless it is marked as such by the seating manufacturer in accordance with **RESNA WC-4:2012, Section 20 or ISO 16840-4:2009 - Part 4.**
- Use of headrests, lateral supports or other positioning accessories should not be used, or relied on as an occupant restraint, unless it is marked as such by the seating manufacturer in accordance with **RESNA WC-4:2012, Section 20 or ISO 16840-4:2009 - Part 4.**
- Aftermarket accessories such as trays, oxygen tank holders, oxygen tanks, IV poles, backpacks, pouches and other items not manufactured by Ki Mobility should be removed and secured separately in the motor vehicle. In the event of an accident these items can become dangerous projectiles, which may injure or kill you or other occupants of the motor vehicle.
- If the wheelchair has been involved in an accident, you should not continue to use it, as it may have suffered fatigue that may not be visible.

**NOTE** - Dangers associated with transit use are cited on top of page 15!

## V. SET UP & USE OF YOUR WHEELCHAIR

### B. Transit Use (Continued)



**DANGER:** Failure to comply with transit use instructions, on pages 13 and 14, could result in severe injury or death!

**NOTE:** To obtain a copy of RESNA or ISO standards please contact the standards organizations below:

#### RESNA

1700 North Moore St., Suite 1540

Arlington, VA 22209

Phone: 703-524-6686

Fax: 703-524-6630

Email: [technicalstandards@resna.org](mailto:technicalstandards@resna.org)

#### ANSI/RESNA Standards:

##### RESNA WC-4:2012, Section 18:

Wheelchair tie-down and occupant restraint systems for use in motor vehicles.

##### RESNA WC-4:2012, Section 19:

Wheelchairs used as seats in motor vehicles.

##### RESNA WC-4:2012, Section 20:

Wheelchair seating systems for use in motor vehicles.

#### International Organization for Standardization (ISO)

ISO Central Secretariat

1, ch. de la Voie-Creuse

CP 56

CH-1211 Geneva 20 Switzerland

Phone: +41 22 749 01 11

Fax : +41 22 733 34 30

Email: [central@iso.org](mailto:central@iso.org)

#### ISO Standards:

**ISO 10542-1:2012 Technical systems and aids for disabled or handicapped persons -- Wheelchair tie-down and occupant-restraint systems --Part1:** Requirements and test methods for all systems.

##### ISO 16840-4:2009 Wheelchair seating -- Part 4:

Seating systems for use in motor vehicles.

##### ISO 7176-19:2008 Wheelchairs -- Part 19:

Wheeled mobility devices for use as seats in motor vehicles.

## V. SET UP & USE OF YOUR WHEELCHAIR

### C. Height Adjustable T-Arms (Fig. 2)

#### 1. Installation

- Slide the outer armpost into the receiver mounted to the wheelchair frame.
- The armrest will automatically lock into place. Check to make sure the locking lever is as shown (Fig. 2 B)

#### 2. Height Adjustment

- Rotate release lever (Fig. 2 A)
- Slide armrest pad up or down to desired height.
- Return lever to locked position against arm post.
- Push arm pad until upper arm post locks firmly into place. Check to make sure the locking lever is as shown (Fig. 2 A)

#### 3. Removing Armrest

- Squeeze release lever (Fig. 2 B) and remove the armrest.

#### 4. Replacing Armrest

- Slide armrest back into receiver.
- The armrest should lock back into place.

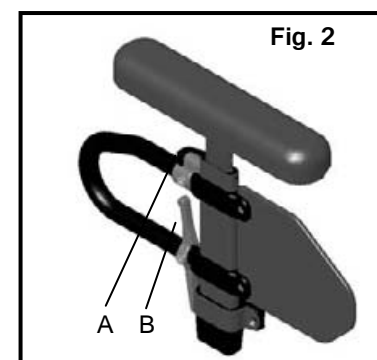

**DANGER:** Failure to comply with the instructions above may result in the armrest accidentally disconnecting from the wheelchair and result in a fall or loss of control and may cause serious injury or death.



**DANGER:** Never attempt to lift the chair by the armrests; they may break or disconnect resulting in a fall or loss of control and may cause serious injury or death.



## V. SET UP & USE OF YOUR WHEELCHAIR

### D. Padded Swing-Away Adjustable Armrests (Fig. 3)

#### 1. Installation

- a) Slide armrest into receiver tube on rear of frame. Ensuring the pin engages the receiver.

#### 2. Swinging Away

- a) Lift armrest up until pin disengages from receiver and rotate to the side.

#### 3. Removing Armrest

- a) Pull armrest straight out of receiver.

#### 4. Adjusting Receiver Angle

- a) Remove two M6 bolts from receiver.
- b) Receiver is now free to rotate in 3° increments. Adjust arm to desired angle.
- c) Slide bolts through locating holes and tighten nuts.

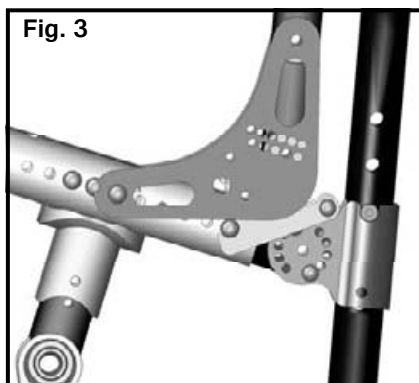

### ⚠ DANGER ⚠

**DANGER:** These arms offer only a lock against rotation and are designed to bear a downward force only. They will remove completely if pulled up on and cannot be used to lift or otherwise handle the chair. Failure to comply with the instructions above may result in the armrest accidentally disconnecting from the wheelchair and result in a fall or loss of control and may cause serious injury or death.

### E. Armrest Warnings

- All Ki Mobility armrests are designed to detach from the chair and will not bear even the weight of this chair.
- NEVER lift this chair by its armrests. The armrests will release and the User may fall.
- Lift this chair only by non-detachable parts of the main frame.

### ⚠ WARNING ⚠

**WARNING:** Failure to heed these instructions may result in a fall, tip-over or loss of control causing severe injury to the user or others.

## V. SET UP & USE OF YOUR WHEELCHAIR

### F. Center of Gravity Adjustment (Fig. 4)

*The most important adjustment on your Rogue wheelchair is the position of the rear axle.*

You can adjust your center of gravity by moving the two camber mount clamps (A) forward or rearward on the seat tube (B).

Moving the camber mount clamps forward shortens the wheelbase and lightens the front end, making your chair more maneuverable. Moving the camber mounts rearward makes the chair more stable and less likely to tip over rearward.

**NOTE-** Changes to the center of gravity may affect the rear seat height (Section J), toe-in/toe-out of the rear wheels (Section I.) and the squareness of the casters (Section L). If you change your center of gravity position, re-adjust all of these settings if necessary.

**NOTE-** Adjusting your chair's center of gravity will require re-adjusting the location of the wheel locks (if provided). See Section S for instructions on adjusting the wheel locks.

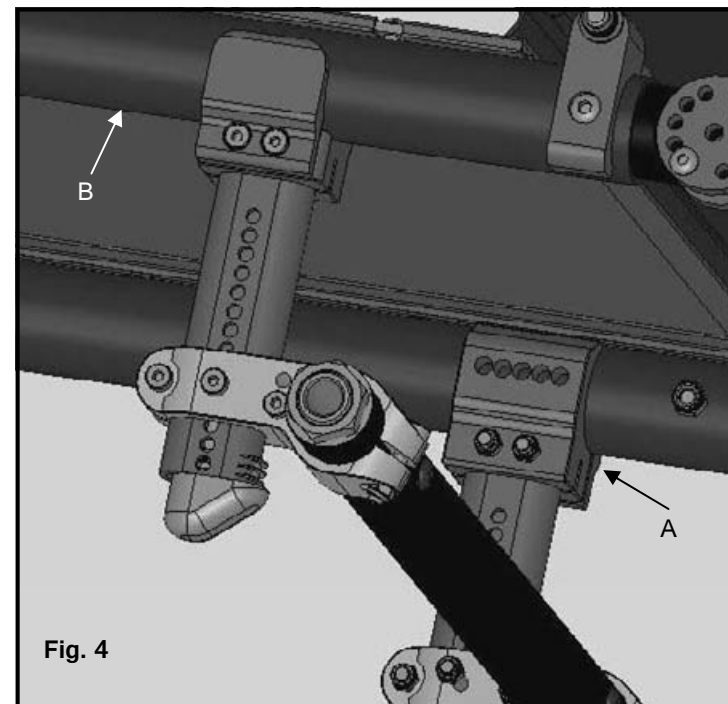

## V. SET UP & USE OF YOUR WHEELCHAIR

### F. Center of Gravity Adjustment (Continued)

To adjust the center of gravity location (Fig. 5):

- Remove both rear wheels.
- Loosen the 2 screws (C) and nuts that secure the camber mounts (A and B) to the seat tubes.
- Slide the camber mounts forward or rearward along the seat tube to the desired hole location.
- Repeat on the other side.
- Make sure the mounts on both sides of the frame are adjusted equally on both sides of the frame before tightening all the screws and nuts.
- Once the camber mount clamps are secured, attach the rear wheels, occupy the chair and maneuver it with a spotter to get a feel for the new adjustment.

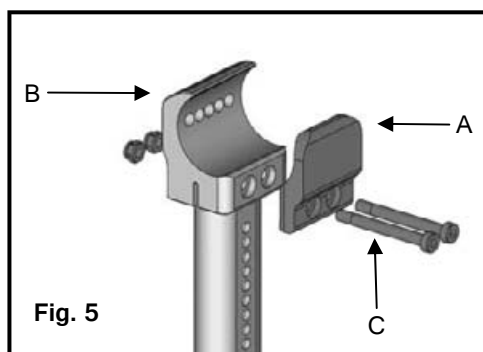

### ⚠ WARNING ⚠

**WARNING:** The more you move your rear wheels forward, the more likely your chair will tip over backwards. Always make adjustments in small increments, and check the stability of your chair with a spotter to prevent a tip-over. We recommend that you use anti-tip tubes until you adapt to the change and are sure you are not at risk to tip over.

### ⚠ DANGER ⚠

**DANGER:** Failure to heed these warnings may cause serious injury or death.

## V. SET UP & USE OF YOUR WHEELCHAIR

### G. Wheel Camber (Fig. 6-8)

Wheel camber, shown as angular relationship (7-A), provides greater side-to-side stability due to the increased width and angle of the wheelbase. It also allows for quicker turning and greater access to the top of the handrims.

Wheel camber is determined by pairs of interchangeable camber adapters (B) which are available from your authorized supplier in 0°, 2°, 4°, 6° and 8° angles.

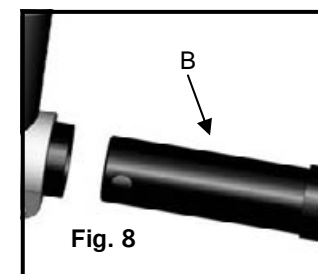
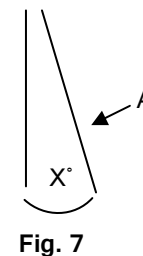
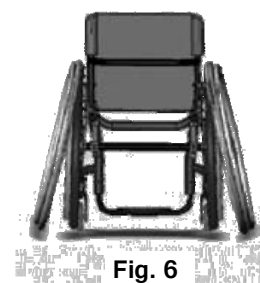

### H. Wheelbase Width Adjustment

Adjusting the wheelbase width allows the rider the option to move the wheels closer or further away from the hips. It also compensates for camber adjustment and gives the proper wheel spacing to maximize pushing efficiency.

**To Adjust the Wheelbase Width (Fig. 9):**

- Loosen the nut (A) with a 24mm wrench and turn the threaded axle sleeve (B) in or out to the desired width.
- Retighten nut.
- Repeat on opposite side.

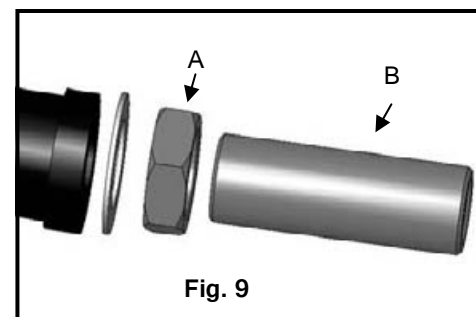

## V. SET UP & USE OF YOUR WHEELCHAIR

### I. Setting Toe to Zero (Fig. 10)

**NOTE**– A wheelchair equipped with 0° camber plugs cannot have a toe-in toe-out condition. This adjustment is only required when using 2°, 4°, 6° and 8° camber adapters.

Toe refers to how well the rear wheels of the chair are aligned relative to the ground. It affects how well the chair will roll. Drag or rolling resistance is optimally minimized when the wheel toe is set to zero.

#### To set Toe to zero:

1. Loosen the cap screws (A) (1 per side) that secure the camber tube clamp.
2. Rotate the camber tube (B) until the screws (C) that secure the camber spuds are level with the ground. The toe is now set at zero.
3. Before tightening the screws (A), make certain that the camber tube is centered left-to-right relative to the wheelchair frame. There should be an equal gap on both sides or none at all.
4. Tighten screws in a balanced fashion—tighten one screw to 50 in./lbs and then the second to 50 in./lbs. Returning to the tighten the first screw to 80 in./lbs. and finally the second screw to 80 in./lbs. Repeat on opposite side.

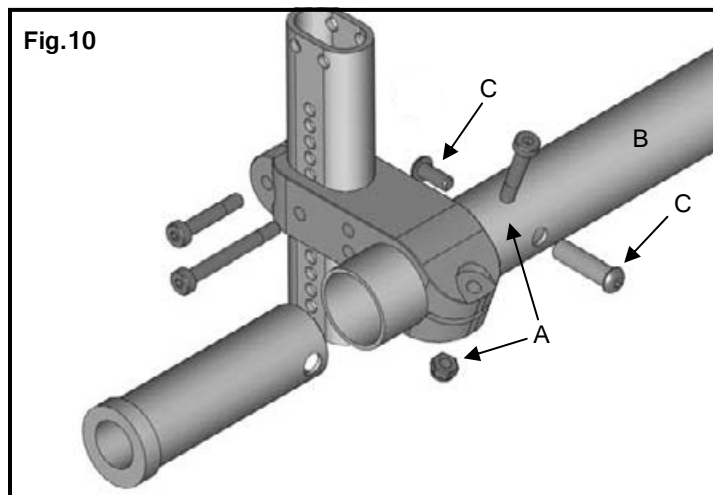

## V. SET UP & USE OF YOUR WHEELCHAIR

### J. Rear Seat Height Adjustment (Fig. 11)

Rear seat height can be adjusted by repositioning the Tubular Component System (TCS).

1. Remove your wheels by depressing the buttons on the quick release axle.
2. Use a 4mm Allen wrench and 8mm open end wrench to remove the two bolts (A) holding the upper and lower mounting brackets together. (See Fig. 11) Reposition the mounting brackets to the desired height and replace the two M5 bolts.
3. Repeat on both sides of the wheelchair.

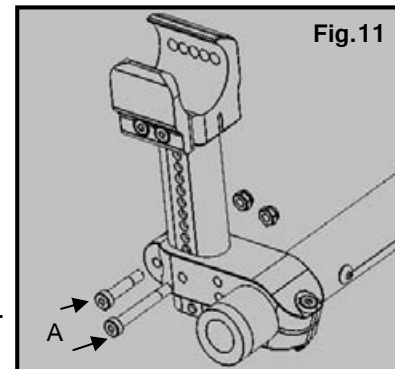

**NOTE** - Height adjustments are in 1/4" increments.

**NOTE**– A front caster adjustment should be made to correspond with any change in seat angle.



**WARNING:** Lowering the seat height at the rear of the seat .5" or 2 positions of 0.25" increments will decrease the rearward stability by 1/2 degree. The more you move your rear wheels forward, the more likely your chair will tip over backwards.

Always make adjustments in small increments, and check the stability of your chair with a spotter to prevent a tip-over. We recommend that you use anti-tip tubes until you adapt to the change and are sure you are not at risk to tip over.



Failure to heed these warnings may cause serious injury or death.

### K. Front Seat Height Adjustment (Fig. 12)

The front seat height can be adjusted in 1/2" increments by repositioning the caster wheel within the fork.

1. Use two 4mm Allen wrenches to remove the cap screws and push the internally threaded axle from one hole location and move up or down to the desired location.
2. Reposition the two 6mm screws and tighten to 80 in./lbs.
3. Re-square caster wheels as noted in item L. Caster Angle Adjustment.

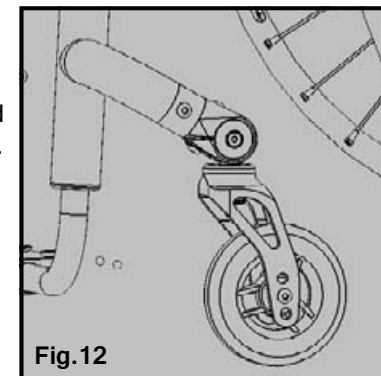

## V. SET UP & USE OF YOUR WHEELCHAIR

### L. Caster Angle Adjustment (Fig. 13, 14)

To maintain optimal performance of your Rogue the front caster housing should always be aligned perpendicular to the ground. Your Rogue is shipped aligned. Many of the adjustments made in properly setting up the wheelchair, however, will result in the caster housing getting out of alignment.

**After all other adjustments are made you should check your caster housing alignment and re-align if the housing is not perpendicular to the ground.**

#### Adjusting the Caster Angle:

For optimum performance, the caster housing should always be at a 90° angle to the floor (perpendicular to the ground).

1. To change the angle you will need an M5 Allen wrench.
2. Loosen the M8 button head cap screw (A) on the bottom of the caster housing wing. (Fig. 13) Then turn the screw on the top of the caster housing wing. (B). Loosening will begin to tilt the caster forward. By tightening you will turn rearward.
3. Turn until you have aligned the caster stem so it is perpendicular to the floor.
4. Place a large right triangle against the flat surface of the fork as shown. (Fig. 14)
5. With the rack and pinion system of the Rogue the casters should always be able to be square.

Fig. 13

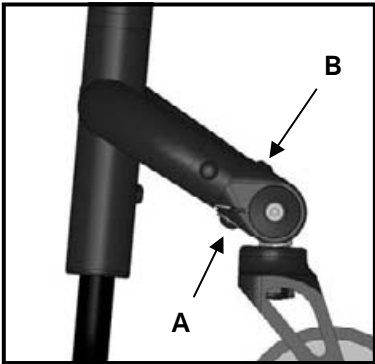
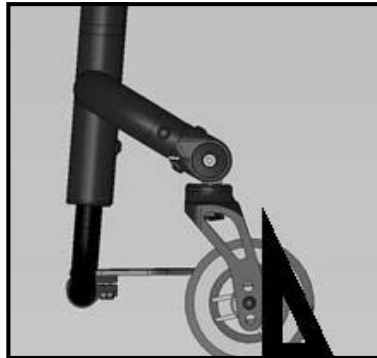

Fig. 14



## V. SET UP & USE OF YOUR WHEELCHAIR

### M. Wheel Installation & Removal

#### 1. Installing Wheels (Fig. 15)

- a) Push in the axle release button on the axle to allow the locking balls to retract. Make note of the difference between the extended and depressed position of the axle release button and its effect on the locking balls on the other end of the axle
- b) Insert the axle into the bearing housing on the wheel if it's separate.
- c) Push on quick release button again and slide axle into axle sleeve.
- d) Release the button to lock axle in sleeve. If release button does not fully extend and the locking balls do not move in to the locked position after releasing the button, the axle length needs to be adjusted.

Fig.15

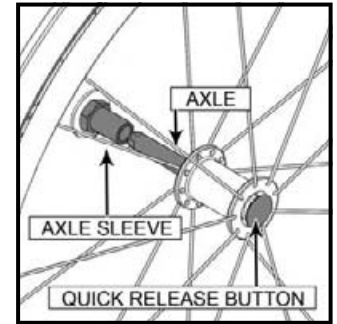
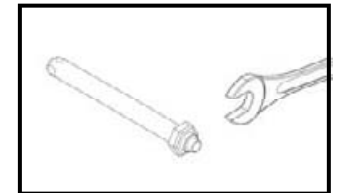

Fig.16



#### 2. Adjusting Axles (Fig. 16)

- a) To adjust the axle you will need a 19mm wrench to turn the adjustment nut. You will also need a 11mm wrench to securely hold the ball detent end of the axle to prevent it from turning.
- b) If the wheel and axle will not lock into the camber plug then the axle requires adjustment. Turn the nut counter-clockwise approximately 1/4 revolution and try to lock the axle into the camber plug. If it doesn't lock, continue making small nut adjustments until it securely locks.
- c) If the wheel is locked on the chair but there is excessive wheel play (the wheel hub can be pushed back and forth on the axle) then adjust the nut clockwise until there is no perceptible gap between the wheel and camber tube and the axle is securely locked onto the chair.

**Review and understand Section M. Wheel Installation & Removal before attempting an axle adjustment!**

#### 3. Removing Wheels

- a) Hold the wheel close to the hub and push in the button on the outside end of the axle.
- b) While still holding the button pull the wheel and axle out of the axle sleeve.

**⚠ DANGER ⚠**

**DANGER:** Make sure the push button is completely extended and the locking balls on the inside of the chair are fully engaged before operating the wheelchair. Failure to do so may result in the wheel falling off and may cause serious injury or death.

## V. SET UP & USE OF YOUR WHEELCHAIR

### N. Adjusting the Footrest (Fig. 17)

#### Height Adjustment of your footrest:

1. Locate the set screw on each side of the frame (A).
2. Loosen the set screw on each side of the frame using an M3 Allen wrench. Do not remove.
3. Adjust footrest tube up or down to achieve the desired height (B).
4. Ensure both sides are adjusted equally.
5. Retighten each set screw to 40 in./lbs.

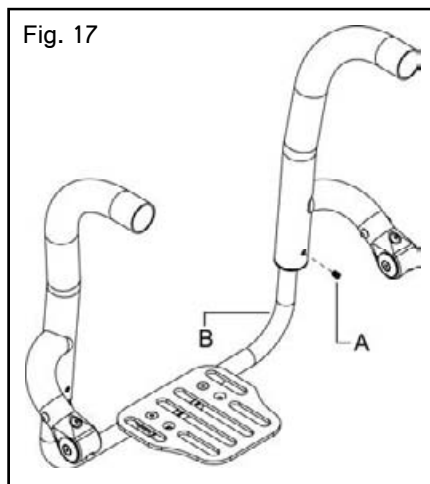

### O. Optional Angle Adjustable Footplate (Fig. 18)

#### To adjust the angle of the optional angle adjustable footplates:

1. Loosen, but do not remove, the two M6 screws securing the footplate to the footplate clamp with a 4mm Allen wrench.
2. Once loose, the footplate will easily rotate around the footrest extension tube.
3. Select the desired position and retighten the two M6 screws to 80 in./lbs.

#### Changing Position of the Optional Aluminum Flip-Up Footplate:

1. Remove both M6 screws from the footplate. There are M6 nylock nuts recessed on the underside of the Clamp. Be sure to prevent these from falling as you loosen the screws.
2. Relocate the footplate once the screws are loose by rotating either forward or rearward depending on desired angle. Once position is achieved reinsert the screws into the appropriate holes.
3. Fit the nuts into the slot underneath the clamp and tighten the screws securely.

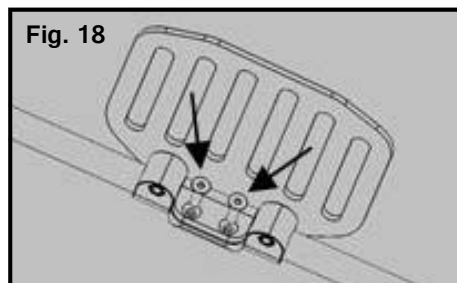

## V. SET UP & USE OF YOUR WHEELCHAIR

### P. Anti-Tips (Fig. 19-21)

Anti-tip tubes help prevent your wheelchair from tipping over backwards. When adjusted properly they provide a significant increase in rearward stability. Your stability can be affected by traversing uneven ground, a ramp, slope or other surface that changes your relationship to gravity. Your stability can also be affected by other forces acting on you and your wheelchair such as someone pushing down or leaning on your push handles or other parts of your chair. This can happen to even the most experienced wheelchair user. People in your environment do not necessarily understand they are impacting your stability.

**Ki Mobility strongly recommends the use of Anti-Tip tubes!**



**Anti-tips must be used at all times.** Whether traversing uneven ground or sitting in a crowded room, the unexpected may occur and your weight can dramatically shift causing a fall which could cause serious injury or death.

#### 1. Inserting Anti-Tip Tubes Into Receiver (Fig. 19)

- a) Press the rear anti-tip release pin on the anti-tip tube so both release pins are drawn inside.
- b) Insert into the anti-tip tube receiver.
- c) Turn the anti-tip tube down until release pin is positioned through the receiver mounting hole.
- d) Insert second anti-tip tube the same way.

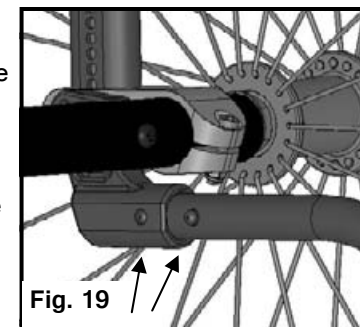

#### 2. Adjusting Anti-Tip Tube Wheel (Fig. 20)

The anti-tip tube wheels may have to be raised or lowered to achieve proper clearance 1 1/2" to 2".

- a) Press the anti-tip wheel release pin so the release pin is drawn inside.
- b) Raise or lower to one of the three predrilled holes.
- c) Release pin.
- d) Adjust the second anti-tip tube wheel the same way. Both wheels should be at exactly the same height.



**DANGER:** Failure to read and heed these instructions may result in damage to your wheelchair, a fall or loss of control causing severe injury to the user or others.

## V. SET UP & USE OF YOUR WHEELCHAIR

### P. Anti-Tips (Continued)

#### 3. Turning Anti-Tip Tubes Up (Fig. 21)

Turn anti-tip tubes up when being pushed by attendant, overcoming obstacles or climbing curbs.

- Press the rear anti-tip tube release pin.
- Hold pin in and turn anti-tip tube up.
- Release pin.
- Repeat with second anti-tip tube.
- Remember to return anti-tip tubes to down position after completing maneuver.

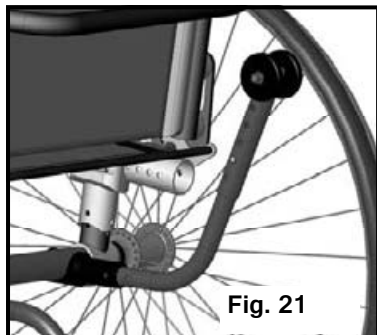

### Q. Upholstery Fabric

- You must immediately replace seat and back upholstery that has worn through and shows signs of failing. If you fail to do so, the seat or back may fail.
- The seat sling material will weaken over time. Look for fraying, thin spots, or stretching of fabrics especially at edges and seams. This should be done weekly.
- The repeated action of transferring to your wheelchair will weaken sling material and result in the need to inspect and replace the seat more often.
- Be aware that laundering or excess moisture will reduce flame retardation of the fabric.
- Contact your wheelchair provider if you have concerns about your seat or back, or feel it needs to be replaced.



**WARNING:** Failure to comply with these instructions may result in damage to your wheelchair, a fall or loss of control causing severe injury to the user or others.

## V. SET UP & USE OF YOUR WHEELCHAIR

### R. Backrest

#### 1. Folding Backrest (Fig. 22 and 23)

- Lift the back release cable that is behind the back frame to release the latch. (Fig. 22) and fold downward towards the seat frame. (Fig. 23) To latch back into place, pull the release cable outward and the back will release and can be pushed back into the upright position. The backrest will automatically latch onto the side frame.
- Ensure a solid engagement onto the latches by pulling back on the backrest frame into the upright position.



Fig. 22

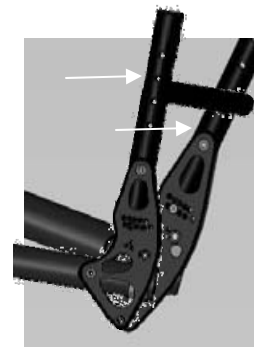

Fig. 23

#### 2. Relaxed Position (Fig. 24)

The Rogue backrest will also open into an extended position by pulling the backrest release cable outward and applying pressure against the back while remaining in the wheelchair.

Fig. 24



## V. SET UP & USE OF YOUR WHEELCHAIR

### R. Backrest (Continued)

#### 3. Backrest Angle Adjustment (Fig. 25)

There are a series of 10 holes used for adjusting the angle of your Rogue backrest (C). Each hole will change the angle by 3 degrees (+/-). Moving the placement of the screw (A) into a locating hole further towards the front of the chair will result in opening of the back angle. Choosing a hole location closer to the rear of the chair results in closing of the back angle.

To adjust the angle of the backrest:

1. Using a 3mm Allen wrench and 8mm socket wrench remove the screw (A) and nut and washer (B) on the backrest plate (Fig. 25) where angle adjustment holes are located (D).
2. Align the backrest tube and saddle (C) with desired hole and reinsert screw (A) through locating holes, plastic saddle and into backrest tube (C). (Fig. 25)
3. Repeat on the opposite side. Taking care to place in same location on both sides of backrest in order to achieve an even backrest angle.
4. Replace washer and retighten the 8mm nut (B) until securely fastened. (Fig. 25)
5. Repeat on opposite side.

**NOTE:** Lowering backrest height or changing the back angle may decrease rearward stability. Always make adjustments in small increments and check the stability of your chair with a spotter to prevent a tip-over.

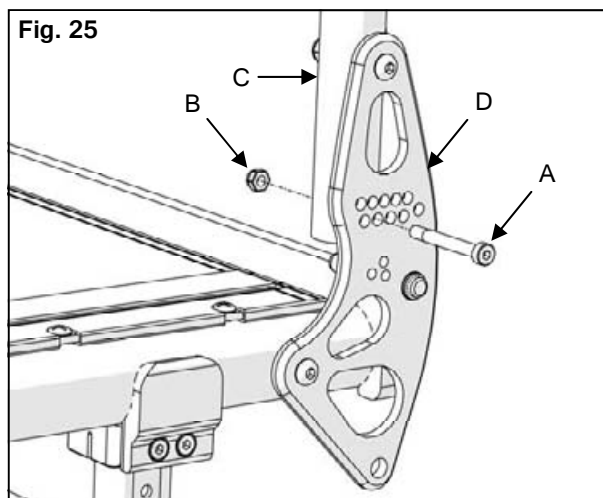

### ⚠ WARNING ⚠

**WARNING:** Failure to heed these instructions may result in a fall, tip-over or loss of control causing severe injury to the user or others.

## V. SET UP & USE OF YOUR WHEELCHAIR

### S. Wheel Locks (Fig. 26, 27)

Rogue wheelchairs are shipped with one of several different types of wheel locks pre-installed.

- Push to Lock
- Pull to Lock
- Push to Lock (flush mount)
- Short thro Scissor

The clamp assembly works the same for all wheel locks.

- a) Using a 5 mm Allen wrench, turn one of the screws in the clamp until it runs easily (less than one turn).
- b) Repeat the same process with the second of the two screws so the clamp can be adjusted on the frame.
- c) Adjust the clamp toward the rear wheel so, when engaged, the wheel lock compresses the tire and prevents any wheel movement. (Fig. 26)
- d) Make sure wheel lock arms embed in tires at least 1/8 inch when locked. If you fail to do so, the locks may not work. (See Fig. 27)
- e) Retighten the screws.

Wheel lock clamps require a torque setting of 100 in./lbs.

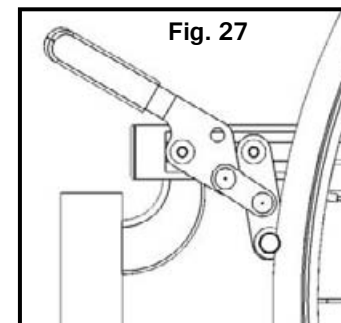
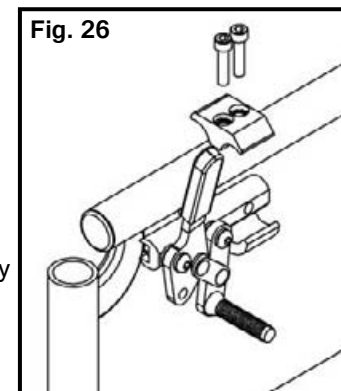

Rear wheel locks are NOT designed to slow or stop a moving wheelchair. Use them only to keep the rear wheels from rolling when your chair is at a complete stop.

- NEVER use rear wheel locks to try to slow or stop your chair when it is moving. Doing so may cause you to veer out of control.
- To keep the rear wheels from rolling, always set both rear wheel locks when you transfer to or from your chair.
- Low pressure in a rear tire may cause the wheel lock on that side to slip and may allow the wheel to turn when you do not expect it.
- Make sure lock arms embed in tires at least 1/8 inch when locked. If you fail to do so, the locks may not work.

### ⚠ DANGER ⚠

**DANGER:** Failure to read or comply with these instructions may result in a fall or loss of control causing severe injury to the user or others.

## V. SET UP & USE OF YOUR WHEELCHAIR

### T. Seat Sling

Seat sling includes a folding strap on the seat to assist in folding the chair.

NOTE– The seat sling folding strap is not intended as a carrying strap.

### U. Cushion Installation

- a) The Tsunami was designed to be used with a proper wheelchair cushion.



**DANGER:** Sitting for long periods of time without a proper wheelchair cushion can cause pressure ulcers which can be serious in nature and result in death.

- b) The standard sling upholstery is provided with loop Velcro type fastener strips. The cushion being used should have hook Velcro type fasteners that can engage the loop of the seat sling to keep the cushion from sliding out from under you. Make sure the cushion is securely attached before transferring or sitting in the wheelchair.
- c) A standard seat sling may not have been provided with your chair. Check with your wheelchair provider if an aftermarket replacement to the original equipment sling has been provided. If so, make sure you follow the instructions for the use provided by the aftermarket manufacturer.



**WARNING:** Failure to properly secure a cushion can cause it to slide out during use or transfers and could result in a fall or loss of control and cause severe injury or death.

## VI. MAINTENANCE

### A. Inspecting Your Wheelchair

Regular and routine maintenance will extend the life of your wheelchair while improving its performance. Wheelchair repairs and the replacement of parts should be done by a qualified technician of an authorized Ki Mobility Supplier.

#### 1. General Inspections

- a) Clean your chair at least once per month. You may need to clean your chair more frequently if you operate it in dirty environments, such as a work site.
- b) Check to be sure that all fasteners are tight. Unless otherwise noted, fasteners should be tightened to 40 in./lbs.
- c) Check Tires and Casters:
- Check the tire for tread wear. Replace the tires if the tread is worn off or has flat spots or visible cracks.
  - If you have inflatable tires with a valve stem, check the pressure and set to the pressure listed on the tire sidewall.



**DANGER:** Replace worn tires. The wheel locks will not grip properly if you fail to maintain the air pressure shown on tire sidewall. This could result in a fall or loss of control and cause severe injury or death.

- d) Check spoke wheels for loose spokes.
- e) Check your wheel locks. As tires wear the wheel locks should be adjusted. **See S. Wheel Locks on Page 30.**
- f) Check your upholstery for tears or sagging. Your upholstery is designed to be tightened because it will stretch over time. **See Q. Upholstery Fabric on Page 27.**



## VI. MAINTENANCE

### A. Inspecting Your Wheelchair (Continued)

- Weekly**
- a) Check wheel locks to be sure they are adjusted correctly.
  - b) Check axle sleeves to ensure the axle sleeve nuts are tight.
  - c) Check for broken, bent or loose spokes.
  - d) Check that casters can spin freely.
  - e) Inspect tires and casters for wear spots.
  - f) Check pneumatic tires for proper inflation.
- Monthly**
- a) Inspect rear wheel axles and tighten if necessary.
  - b) Inspect caster housing bearings for hair build up and remove if necessary.
  - c) Inspect wheel locks to be sure assembly is tight. Make sure wheel locks properly engage the tires.
  - d) Check that all fasteners are tight and secure.
  - e) Inspect hand grips to ensure they are not loose.
  - f) Inspect frame for any deformities, defects, cracks, dimples or bends. These could be signs of fatigue in the frame which could result in a failure of the chair. **Discontinue use of the wheelchair immediately and contact your authorized Ki Mobility dealer.**
- Annually**
- a) Have wheelchair checked and adjusted by a qualified technician.

#### **WARNING**

**WARNING:** After adjustments and before using this wheelchair, make sure all of the fasteners are tight and secure or injury or damage may occur.

#### **CAUTION**

**CAUTION:** Do not over-tighten fasteners as this could damage the frame tubing.

#### **DANGER**

**DANGER:** Failure to read and comply with these instructions may result in a fall or loss of control causing severe injury or death to the user or others.

## VI. MAINTENANCE

### B. Cleaning

#### 1. Axles and wheels

- a) Clean around the axles and wheels WEEKLY with a damp rag.
- b) Hair and lint will lodge in the caster housing. Disassemble the caster housing every six months to remove entangled hair.

**NOTE:** Do not use WD-40 or any other penetrating oil on this wheelchair. This will destroy the sealed bearings.

**NOTE:** Do not use any chemical cleaning agents on casters or tires.

#### 2. Upholstery

- a) Hand-wash only (machine washing can cause damage to the fabric).
- b) Line dry only. DO NOT machine dry; heat from the dryer will damage fabric.

#### **WARNING**

**WARNING:** Failure to read and comply with these instructions may result in damage to your wheelchair, a fall or loss of control causing severe injury to the user or others.

### C. Storage

- a) When not in use, keep your chair in a clean, dry area. Failure to do so may result in your chair rusting and/or corroding.
- b) If your chair has been in storage for more than a few weeks you should make sure it is working properly. You should inspect and service, if necessary, all items in section VI. A. Inspecting your Wheelchair.
- c) If your chair has been in storage for more than two months, it should be serviced and inspected by your authorized supplier before you use it.

#### **WARNING**

**WARNING:** Failure to read and comply with these instructions may result in damage to your wheelchair, a fall or loss of control causing severe injury to the user or others.

## VII. WARRANTY

Ki Mobility warrants the frame and quick-release axles of this wheelchair against defects in materials and workmanship for the life of the original purchaser. All other Ki Mobility-made parts and components of this wheelchair are warranted against defects in materials and workmanship for one year from the date of first consumer purchase.

The expected life of the frame is five years.

### Limitations to the Warranty

1. We do not warrant:
  - a) Wear items: Upholstery, tires, armrest pads, tubes, armrests and push-handle grips.
  - b) Damage resulting from neglect, misuse or from improper installation or repair.
  - c) Damage from exceeding weight limit.
2. This warranty is VOID if the original chair serial number tag is removed or altered.
3. This warranty is VOID if the original chair has been modified from its original condition and it is determined the modification resulted in failure.
4. This warranty applies in the USA only. Check with your supplier to find out if international warranties apply.

### Ki Mobility's Responsibility

Ki Mobility's only liability is to replace or repair, at our discretion, the covered parts. There are no other remedies, expressed or implied.

### Your Responsibility

- a) Notify Ki Mobility, via an authorized supplier, prior to the end of the warranty period and get a return authorization (RA) for the return or repair of the covered parts.
- b) Have the supplier send the authorized return, freight pre-paid, to:  
**Ki Mobility**
- c) Pay any charges for labor to repair or install parts.

