



## **Top End<sup>®</sup> Crossfire<sup>™</sup>**

Crossfire T6, Crossfire Titanium, Crossfire All Terrain

### **EN Crossfire series Wheelchair User Manual**

This manual **MUST** be given to the user of the product.  
**BEFORE** using this product, read this manual and save for future reference.



**Yes, you can.<sup>®</sup>**

© 2013 Invacare® Corporation

All rights reserved. Republication, duplication or modification in whole or in part is prohibited without prior written permission from Invacare. Trademarks are identified by ™ and ®. All trademarks are owned by or licensed to Invacare Corporation or its subsidiaries unless otherwise noted.

Shimano is a registered trademark of Shimano Inc.

Please record your serial number SN# \_\_\_\_\_.

The SN is required for any warranty claims and placing aftermarket parts orders.

# Contents

<b>I</b>	<b>General</b> . . . . .	<b>5</b>
1.1	Symbols . . . . .	5
1.2	Intended Use . . . . .	5
1.3	Service Life . . . . .	5
1.4	Dealer/Technician Information . . . . .	5
<b>2</b>	<b>Safety</b> . . . . .	<b>6</b>
2.1	Safety . . . . .	6
	Safety/Handling of Wheelchairs . . . . .	9
2.2	Stability and Balance . . . . .	10
2.3	Reaching, Leaning and Bending . . . . .	12
2.4	Coping with Everyday Obstacles . . . . .	13
2.5	A Note to Wheelchair Assistants . . . . .	13
2.6	Tipping . . . . .	13
2.7	Stairways . . . . .	13
2.8	Escalators . . . . .	14
2.9	Transferring To and From Other Seats . . . . .	14
2.10	Safety Inspection Checklist . . . . .	15
<b>3</b>	<b>Overview</b> . . . . .	<b>17</b>
3.1	Label Locations . . . . .	17
3.2	Typical Product Parameters . . . . .	18
3.3	Component Identification . . . . .	27
3.4	Tire Pressure Conversion . . . . .	28
<b>4</b>	<b>Operation</b> . . . . .	<b>29</b>
4.1	Adjusting/Replacing Standard Footrest . . . . .	29
4.2	Replacing/Adjusting Optional Adjustable Angle Footrest . . . . .	29
4.3	Unfolding/Folding the Back . . . . .	31
4.4	Back Angle Adjustment . . . . .	32
4.5	Adjustable Tension Back Upholstery . . . . .	37
4.6	Back Height Adjustment . . . . .	42
4.7	Adjusting Quick-Release Axles . . . . .	43
4.8	Adjusting Quad-Release Handles . . . . .	43
4.9	Removing Play from Rear Wheels . . . . .	44
4.10	Adjusting Wheelbase Length, Adjusting Center of Gravity (COG) . . . . .	45
4.11	Reposition the Camber Tube . . . . .	47
4.12	Repositioning the Camber Tube Clamp Socket Screws . . . . .	48
4.13	Adjusting Wheelbase Width . . . . .	49
4.14	Adjusting the Camber Tube . . . . .	50
4.15	Determining/Setting Toe In/Toe Out . . . . .	51
4.16	Adjusting Fork Tension . . . . .	52
4.17	Changing Wheel Lock Handle Position . . . . .	53
4.18	Converting Wheel Lock From Push-to-Lock or Pull-to-Lock . . . . .	54
4.19	Adjusting/Replacing Anti-tipper . . . . .	55
<b>5</b>	<b>Service</b> . . . . .	<b>58</b>
5.1	Installing the Swingaway Padded Armrest Socket . . . . .	58
5.2	Installing/Removing/Adjusting the Swingaway Padded Armrest . . . . .	60
5.3	Removing/Installing Foldover Back Upholstery . . . . .	61
5.4	Removing/Installing the Back Frame . . . . .	62
5.5	Replacing Adjustable Tension Seat Upholstery . . . . .	63
5.6	Replacing Screw-On Seat Upholstery Option . . . . .	64
5.7	Removing/Installing Rear Wheels . . . . .	65
5.8	Replacing Quad-Release Axles . . . . .	66
5.9	Handrim Replacement . . . . .	67
5.10	Repairing/Replacing Rear Wheel, Tire/Tube . . . . .	68
5.11	Removing/Installing the Camber Tube . . . . .	69
5.12	Removing/Installing/Repositioning the Caster Assemblies . . . . .	70

5.13	Removing/Installing the Fork Assembly . . . . .	72
5.14	Removing/Installing the Elastomers (Suspension Forks Only) . . . . .	74
5.15	Replacing/Adjusting the Wheel Locks . . . . .	75
<b>6</b>	<b>Maintenance . . . . .</b>	<b>76</b>
6.1	Maintenance . . . . .	76
	Replacing/Repairing Rear Wheel Tire/Tube . . . . .	76
	Replacing/Repairing Caster Tire/Tube . . . . .	77
<b>7</b>	<b>Troubleshooting . . . . .</b>	<b>78</b>
7.1	Troubleshooting . . . . .	78
<b>8</b>	<b>Options . . . . .</b>	<b>79</b>
8.1	Options. . . . .	79
<b>9</b>	<b>Warranty . . . . .</b>	<b>84</b>
9.1	Warranty Information . . . . .	84
9.2	Usability Survey . . . . .	86

# I General

## I.1 Symbols

### Warnings

Signal words are used in this manual and apply to hazards or unsafe practices which could result in personal injury or property damage.

See the information below for definitions of the signal words.



#### **DANGER!**

– Danger indicates an imminently hazardous situation which, if not avoided, will result in death or serious injury.



#### **WARNING!**

– Warning indicates a potentially hazardous situation which, if not avoided, could result in death or serious injury.



#### **CAUTION!**

– Caution indicates a potentially hazardous situation which, if not avoided, may result in property damage or minor injury or both.



– Indicates a hazardous situation that could result in damage to property if it is not avoided.



Gives useful tips, recommendations and information for efficient, trouble-free use.



This product complies with Directive 93/42/EEC concerning medical devices.

The launch date of this product is stated in the EC declaration of conformity.

## I.2 Intended Use

The intended use for the manual (mechanical) wheelchair is to provide mobility and transportation of physically impaired persons. The manual wheelchair is intended for ongoing daily use. The models offer a wide range of customization which allows for a better fit for the end user resulting in comfort, lightweight, easier propelling, transferring, and smooth ride. The manual wheelchair is intended for indoor and outdoor use on firm surfaces free of climbing obstacles. All other uses are prohibited.

## I.3 Service Life

The expected service life of this product is five years when used daily and in accordance with the safety instructions, maintenance intervals and correct use, stated in this manual. The effective service life can vary according to frequency and intensity of use.

## I.4 Dealer/Technician Information

The term “qualified technician” in this manual refers to an Invacare qualified technician or a Shimano® certified bicycle repair technician.

---

## 2 Safety

---

### 2.1 Safety

The safety section contains important information for the safe operation and use of this product.

#### General Guidelines

**WARNING!**

- Do not use this product or any available optional equipment without first completely reading and understanding these instructions and any additional instructional material such as owner’s manuals, service manuals or instruction sheets supplied with this product or optional equipment. If you are unable to understand the warnings, cautions or instructions, contact a healthcare professional, dealer or technical personnel before attempting to use this equipment - otherwise, injury or damage may occur.

**WARNING!****ACCESSORIES**

- Invacare products are specifically designed and manufactured for use in conjunction with Invacare accessories. Accessories designed by other manufacturers have not been tested by Invacare and are not recommended for use with Invacare products.



– THE INFORMATION CONTAINED IN THIS DOCUMENT IS SUBJECT TO CHANGE WITHOUT NOTICE.

- Check all parts for shipping damage and test before using. In case of damage, do NOT use. Contact Invacare/Carrier for further instruction.

**WARNING!****Wheelchair User**

- As a manufacturer of wheelchairs, Invacare endeavors to supply a wide variety of wheelchairs to meet many needs of the end user. However, final selection of the type of wheelchair to be used by an individual rests solely with the user and his/her healthcare professional capable of making such a selection.

**WARNING!****Wheelchair Tie Down Restraints**

- Invacare recommends that wheelchair users not be transported in vehicles of any kind while in wheelchairs. As of this date, the Department of Transportation has not approved any tie-down systems for transportation of a user while in a wheelchair, in a moving vehicle of any type.
- It is Invacare's position that users of wheelchairs should be transferred into appropriate seating in vehicles for transportation and use be made of the restraints made available by the auto industry. Invacare cannot and does not recommend any wheelchair transportation systems.

**Stability Warning**

- The position of the footrest, camber tube (COG - Center of Gravity), seat angle, back angle, the tautness of the back upholstery as well as the user's condition are directly related to the wheelchairs stability. Any change to one or any combination of the six may cause the wheelchair to decrease in stability. Use EXTREME caution when using a new seating position. The addition of anti-tippers may be required.



When changes to the left hand column occur, follow across the chart and refer to the procedure to maintain the proper stability, safety and handling of the wheelchair.

	FOOTREST POSITION	CAMBER TUBE (COG)	BACK ANGLE	BACK UPHOLSTERY	USER CONDITION	SEAT ANGLE
FOOTREST POSITION	●		✓		✓	✓
CAMBER TUBE (COG)		●	✓		✓	✓
BACK ANGLE	✓		●	✓	✓	✓
BACK UPHOLSTERY			✓	●	✓	✓
USER CONDITION	✓	✓	✓	✓	●	✓
SEAT ANGLE	✓	✓	✓	✓	✓	●

**WARNING!****Repair and Service Information**

– Unless otherwise noted, all service and adjustments should be performed while the wheelchair is unoccupied.

**Operating Information**

- To determine and establish your particular safety limits, practice bending, reaching and transferring activities in several combinations in the presence of a qualified healthcare professional before attempting active use of the wheelchair.
- DO NOT attempt to reach objects if you have to move forward in the seat.
- DO NOT attempt to reach objects if you have to pick them up from the floor by reaching down between your knees.
- DO NOT lean over the top of the back upholstery to reach objects from behind as this may cause the wheelchair to tip over.
- DO NOT shift your weight or sitting position toward the direction you are reaching as the wheelchair may tip over.
- DO NOT tip the wheelchair without assistance.
- DO NOT attempt to stop a moving wheelchair with wheel locks. Wheel locks are not brakes.
- Never leave an unoccupied wheelchair on an incline.
- DO NOT use an escalator to move a wheelchair between floors. Serious bodily injury may occur.



**WARNING!****Operating Information**

- DO NOT operate on roads, streets or highways.
- DO NOT climb, go up or down ramps or traverse slopes greater than 9°.
- DO NOT attempt to move up or down an incline with a water, ice or oil film.
- DO NOT attempt to ride over curbs or obstacles. Doing so may cause your wheelchair to turn over and cause bodily harm or damage to the wheelchair.
- DO NOT attempt to lift the wheelchair by any removable (detachable) parts. Lifting by means of any removable (detachable) parts of a wheelchair may result in injury to the user or damage to the wheelchair.
- DO NOT stand on the frame of the wheelchair.
- ALWAYS keep hands and fingers clear of moving parts to avoid injury.

**Safety/Handling of Wheelchairs**

“Safety and Handling” of the wheelchair requires the close attention of the wheelchair user as well as the assistant. This manual points out the most common procedures and techniques involved in the safe operation and maintenance of the wheelchair. It is important to practice and master these safe techniques until you are comfortable in maneuvering around the frequently encountered architectural barriers.

Use this information only as a “basic” guide. The techniques that are discussed on the following pages have been used successfully by many.

Individual wheelchair users often develop skills to deal with daily living activities that may differ from those described in this manual. Invacare recognizes and encourages each individual to try what works best for him/her in overcoming architectural obstacles that they may encounter, however, ALL WARNINGS and CAUTIONS given in this manual MUST be followed. Techniques in this manual are a starting point for the new wheelchair user and assistant with “safety” as the most important consideration for all.

## 2.2 Stability and Balance



### **WARNING!**

- ALWAYS wear your seat positioning strap. Inasmuch as the seat positioning strap is an option on this wheelchair (you may order with or without the seat positioning strap), Invacare strongly recommends ordering the seat positioning strap as an additional safeguard for the wheelchair user. The seat positioning strap is a positioning strap only. It is not designed for use as a safety device withstanding high stress loads such as auto or aircraft safety belts. If signs of wear appear, strap **MUST** be replaced **IMMEDIATELY**.
- **DO NOT** attempt to lift a wheelchair by lifting on any removable (detachable) parts. Lifting by means of any removable (detachable) parts of the wheelchair may result in injury to the user or damage to the wheelchair.
- ALWAYS check hand grips for looseness before using the wheelchair. If loose and/or worn, replace **IMMEDIATELY**.
- Anti-tippers **MUST** be attached at all times. Inasmuch as the anti-tippers are an option on this wheelchair (you may order with or without the anti-tippers), Invacare strongly recommends ordering the anti-tippers as an additional safeguard for the wheelchair user.
- **DO NOT** climb, go up, or down ramps or traverse slopes greater than 9°.
- Invacare strongly recommends proceeding down ramps or slopes slowly to avoid hard braking or sudden stops.



### **WARNING!**

- Be aware that carrying heavy objects on your lap while occupying the wheelchair may adversely affect the stability of the wheelchair, resulting in serious bodily injury to the user, damage to the wheelchair and surrounding property.
- This wheelchair has been designed to accommodate one individual. If more than one individual occupies the wheelchair this may adversely affect the stability of the wheelchair, resulting in serious bodily injury to the user and passenger and damage the wheelchair and surrounding property.

To assure stability and proper operation of your wheelchair, you **MUST** at all times maintain proper balance. Your wheelchair has been designed to remain upright and stable during normal daily activities as long as you **DO NOT** move beyond the center of gravity.

Virtually all activities which involve movement in the wheelchair have an effect on the center of gravity. Invacare recommends using seat positioning straps for additional safety while involved in activities that shift your weight.

**DO NOT** lean forward out of the wheelchair any further than stability will allow. Make sure casters are pointing in the forward position whenever you lean forward. This can be achieved by advancing the wheelchair and then reversing it in a straight line.

**WARNING!**

- DO NOT attempt to reach objects if you have to move forward in the seat or pick them up from the floor by reaching down between your knees.
- The position of the footrest, camber tube, back angle, the tautness of the back upholstery as well as the user's condition are directly related to the wheelchair's stability. Any change to one or any combination of the five may cause the wheelchair to decrease in stability. Use EXTREME caution when using a new seating position. The addition of anti-tippers may be required.

Many activities require the wheelchair owner to reach, bend and transfer in and out of the wheelchair. These movements will cause a change to the normal balance, the center of gravity, and the weight distribution of the wheelchair.

To determine and establish your particular safety limits, practice bending, reaching and transferring activities in several combinations in the presence of a qualified health-care professional before attempting active use of wheelchair.

Proper positioning is essential for your safety. When reaching, leaning, bending forward, it is important to use the front casters as a tool to maintain stability and balance.

- Lengthening the wheelbase **(A)** will increase the stability and maintain standard maneuverability of wheelchair.
- Shortening the wheelbase **(B)** will decrease the stability, increase the maneuverability and distribute additional weight onto the rear wheels.

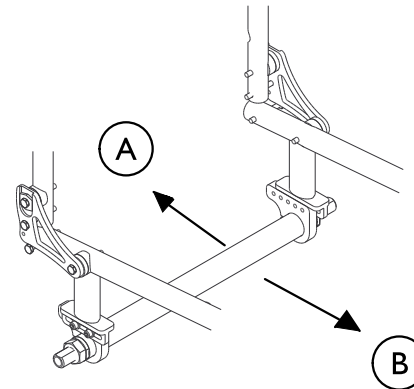
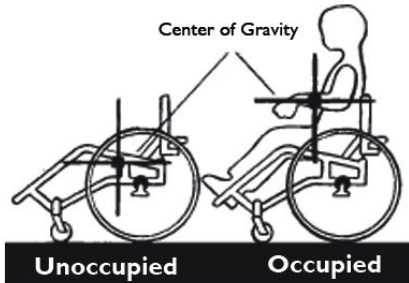

## 2.3 Reaching, Leaning and Bending



### **WARNING!**

- DO NOT attempt to reach objects if you have to move forward in the seat.
- DO NOT attempt to reach objects if you have to pick them up from the floor by reaching down between your knees.
- DO NOT lean over the top of the back upholstery to reach objects from behind as this may cause the wheelchair to tip over.
- DO NOT shift your weight or sitting position toward the direction you are reaching as the wheelchair may tip over.

### **Reaching, Leaning, or Bending Forward**



Position the front casters so that they are extended as far forward as possible and engage wheel locks..

### **Reaching, Leaning, or Bending Backwards**



Position wheelchair as close as possible to the desired object. Point front casters forward to create the longest possible wheelbase.

Reach back only as far as your arm will extend without changing your sitting position.

## 2.4 Coping with Everyday Obstacles

Coping with the irritation of everyday obstacles can be alleviated somewhat by learning how to manage your wheelchair. Keep in mind your center of gravity to maintain stability and balance.

## 2.5 A Note to Wheelchair Assistants

When assistance to the wheelchair user is required, remember to use good body mechanics. Keep your back straight and bend your knees whenever tilting the wheelchair or traversing curbs, or other impediments.



### **WARNING!**

- Do not attempt to lift a wheelchair by lifting on any removable (detachable) parts. Lifting by means of any removable (detachable) parts of a wheelchair may result in injury to the user or damage to the wheelchair.

Also, be aware of any removable (detachable) parts. These **MUST NEVER** be used to move the wheelchair or as lifting supports, as they may be inadvertently released, resulting in possible injury to the user and/or assistant(s).

When learning a new assistance technique, have an experienced assistant help you before attempting it alone.

## 2.6 Tipping



### **WARNING!**

- **DO NOT** tip the wheelchair without assistance.
- When lowering the front casters of the wheelchair, **DO NOT** let the wheelchair drop the last few inches to the ground. This could result in injury to the occupant.

After mastering the techniques of tipping the wheelchair, use one of the following methods to tackle curbs, short stairs, etc.

## 2.7 Stairways



### **WARNING!**

- Extreme caution is advised when it is necessary to move an occupied or unoccupied wheelchair up or down the stairs. Invacare recommends that, if possible, the user be removed from the wheelchair prior to moving. Invacare recommends using two assistants and making thorough preparations. Make sure to use only secure, non-detachable parts for hand-held supports.

Follow this procedure for moving the wheelchair between floors when an elevator is not available:

## Moving Up Stairs

1. If necessary, rotate the anti-tippers so the wheels are facing up.
2. One assistant (positioned behind the wheelchair), securely grasps a non-removable (non-detachable) part of the wheelchair for leverage and tilts the wheelchair back to the balance point.
3. After the wheelchair has been tilted back to the balance point, the assistant behind the wheelchair backs the wheelchair up against the first step.
4. The second assistant (positioned in the front of the wheelchair), with a firm hold on a non-detachable part of the framework, lifts the wheelchair up and on to the next stair above and steadies the wheelchair as the assistant behind the wheelchair places one foot on the next stair above and repeats process.
5. The wheelchair should not be lowered until the last stair has been negotiated and the wheelchair has been rolled away from the stairway.
6. If necessary, rotate the anti-tippers so the wheels are facing down.



## Moving Down Stairs

1. If necessary, rotate the anti-tippers so the wheels are facing up.
2. One assistant (positioned behind the wheelchair), securely grasps a non-removable (non-detachable) part of the wheelchair for leverage and tilts the wheelchair back to the balance point.

3. After the wheelchair has been tilted back to the balance point, the assistant behind the wheelchair rolls the wheelchair up to the edge of the first step.
4. The second assistant (positioned in the front of the wheelchair), with a firm hold on a non-detachable part of the framework, lowers the wheelchair down and on to the next stair below and steadies the wheelchair as the assistant in the rear places one foot on the next stair below and repeats process.
5. The wheelchair should not be lowered until the last stair has been negotiated and the wheelchair has been rolled away from the stairway.
6. If necessary, rotate the anti-tippers so the wheels are facing down.

## 2.8 Escalators



### **WARNING!**

- DO NOT use an escalator to move a wheelchair between floors. Serious bodily injury may occur.

## 2.9 Transferring To and From Other Seats



### **WARNING!**

- Before attempting to transfer in or out of the wheelchair, every precaution should be taken to reduce the gap distance.
- Turn both casters parallel to the object you are transferring onto. Also be certain the wheel locks are engaged to help prevent the wheels from moving.
- When transferring, position yourself as far back as possible in the seat. This will prevent damaged upholstery and the possibility of the wheelchair tipping forward.

 This activity may be performed independently provided you have adequate mobility and upper body strength.



Position the wheelchair as close as possible along side the seat to which you are transferring, with the front casters parallel to it. Remove the armrest, if installed. Engage wheel locks. Shift body weight into seat with transfer.

During independent transfer, little or no seat platform will be beneath you. Use a transfer board if at all possible.

## 2.10 Safety Inspection Checklist

 Every six months, take your wheelchair to a qualified technician for a thorough inspection and servicing. Regular cleaning will reveal loose or worn parts and enhance the smooth operation of your wheelchair. To operate properly and safely, your wheelchair **MUST** be cared for just like any other vehicle. Routine maintenance will extend the life and efficiency of your wheelchair. Clean upholstery with mild soap and water or spray disinfectant using a sponge. **DO NOT** use bleach or wash in a washing machine.



### CAUTION!

– As with any vehicle, the wheels and tires should be checked periodically for cracks and wear, and should be replaced if damaged.

Initial adjustments should be made to suit your personal body structure and preference. Thereafter follow these maintenance procedures:

#### Inspect Initially

- Ensure wheelchair rolls straight (no excessive drag/pull to one side).
- Ensure wheel locks Do not interfere with tires when rolling.
- Ensure pivot points are free of wear and looseness.
- Ensure wheel locks are easy to engage and prevent the wheels from moving.
- Ensure that the casters are free of debris.
- Inspect seat and back upholstery for rips or sagging.
- Inspect upholstery fastening flaps to ensure they securely latch.
- Inspect seat positioning strap for any signs of wear. Ensure buckle latches. Verify hardware that attaches strap to frame is secure and undamaged. Replace if necessary.
- Ensure hand grips (if equipped) are not loose.
- Ensure quick release axles and camber inserts are clean.
- Ensure camber bar mounting clamps are securely tightened.
- Ensure quick/quad release axles lock properly.
- Ensure no excessive side movement or binding when lifted and spun.
- Inspect handrims for signs of rough edges or peeling.
- Inspect spokes for bent or broken spokes.
- Ensure all spokes are uniformly tight.
- Clean upholstery and armrests.

- Inspect wheel/fork assembly for proper tension by spinning caster; caster should come to a gradual stop.
- Loosen/tighten locknut if wheel wobbles noticeably or binds to a stop.
- Ensure wheel bearings are clean and free of moisture.
- Inspect tires for flat spots and wear.
- If pneumatic tires check for proper inflation.
- Check that all labels are present and legible. Replace if necessary.

### **Inspect/Adjust Weekly**

- Ensure wheel locks are easy to engage and prevent the wheels from moving.
- Ensure that the casters are free of debris.
- Ensure hand grips (if equipped) are not loose.
- Ensure quick release axles and camber inserts are clean.
- Ensure quick/quad release axles lock properly.
- Inspect handrims for signs of rough edges or peeling.
- Inspect spokes for bent or broken spokes.
- Ensure all spokes uniformly tight.
- Inspect wheel/fork assembly for proper tension by spinning caster; caster should come to a gradual stop.
- Inspect tires for flat spots and wear.
- If pneumatic tires check for proper inflation.

### **Inspect /Adjust Monthly**

- Ensure wheel locks Do not interfere with tires when rolling.
- Ensure that the casters are free of debris.
- Ensure pivot points are free of wear and looseness.
- Inspect upholstery fastening flaps to ensure they securely latch.
- Inspect seat positioning strap for any signs of wear. Ensure buckle latches. Verify hardware that attaches strap to frame is secure and undamaged. Replace if necessary.
- Ensure camber bar mounting clamps are securely tightened.

- Loosen/tighten locknut if wheel wobbles noticeably or binds to a stop.
- Ensure wheel bearings are clean and free of moisture.

### **Inspect/Adjust Periodically**

- Ensure wheelchair rolls straight (no excessive drag/pull to one side).
- Ensure wheel locks are easy to engage.
- Ensure that the casters are free of debris.
- Inspect seat and back upholstery for rips or sagging.
- Ensure camber bar mounting clamps are securely tightened.
- Ensure no excessive side movement or binding when lifted and spun.
- Inspect handrims for signs of rough edges or peeling.
- Clean upholstery and armrests.
- Ensure wheel bearings are clean and free of moisture.
- Check that all labels are present and legible. Replace if necessary.



# 3 Overview

## 3.1 Label Locations

NO WHEELCHAIR HAS BEEN APPROVED FOR USE AS A SEATING SURFACE WITHIN A MOTOR VEHICLE. THIS LABEL IS FOR INFORMATIONAL PURPOSES ONLY. LIABILITY ISSUES WERE NOT CONSIDERED IN THE ATTACHMENT OF THIS LABEL.

AUCUN FAUTEUIL ROULANT N'A ÉTÉ APPROUVÉ POUR ÊTRE UTILISÉ COMME SIÈGE À L'INTÉRIEUR D'UN VÉHICULE MOTORISÉ. CETTE ÉTIQUETTE NE PEUT ÊTRE UTILISÉE QU'À TITRE D'INFORMATION ET N'A PAS ÉTÉ AFFICHÉE ICI POUR DES RAISONS DE RESPONSABILITÉ LÉGALE

**▲WARNING** Detent balls should extend beyond the diameter of the axle bushing for a positive lock. Keep detent balls clean. P/N 1020960 Rev D

**WEIGHT CAPACITY**  
250 LBS. (114 kgs.)  
REFER TO OWNER'S MANUAL  
P/N 111101

**Serial Number Label Location**

**▲WARNING** Refer to Owner's Manual BEFORE lengthening or shortening wheelbase. 1086191

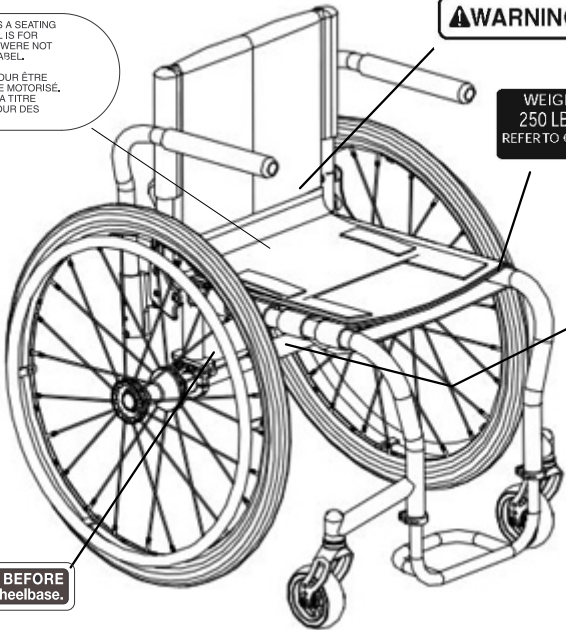

### 3.2 Typical Product Parameters



All specifications are approximate.

<b>Crossfire T6</b>	
<b>FRAME:</b>	6061T6 Aluminum
<b>FRONT FRAME:</b>	Tapered front end (Standard), V-Style (Optional)
<b>FRONT FRAME ANGLE:</b>	70°, 75°, 80°, 85° or 90°
<b>FOOTREST:</b>	Tubular footrest in same material as frame (Standard), Adjustable Angle NCO, Plastic or Carbon Fiber Cover (Optional)
<b>SEAT HEIGHT</b>	
FRONT:	16 to 21 inches (40.6 to 53.3 cm) (Fixed)
REAR:	14 to 20 Inches (35.6 to 50.8 cm) (Fixed), Ergo Level Seat (Optional)
<b>ARMS (OPTIONAL):</b>	Swing-away Style
<b>SIDE GUARDS (OPTIONAL)</b>	
FOLDING BACK:	Removable, Folding, Removable with Fender
FIXED BACK:	Fixed Aluminum, Fixed Carbon Fiber
<b>SEAT WIDTH:</b>	12 to 18 inches (30.5 to 45.7 cm) (Standard), 19 to 20 inches (48.3 to 50.8 cm) (Optional), Tapered Seat Width (Optional)

<b>Crossfire T6</b>	
<b>SEAT DEPTH:</b>	14 to 18 inches (35.6 to 45.7 cm) (Standard), 19 to 20 inches (48.3 to 50.8 cm) (Optional)
<b>BACK STYLE:</b>	Folding (Standard), Fixed (Optional)
<b>BACK HEIGHT</b> ADJUSTABLE:	9 to 11, 10 to 14, 12 to 16, 14 to 18, or 16 to 20 inches (20.32 to 27.94, 25.4 to 35.56, 30.48 to 40.64, 35.56 to 45.72, 40.64 to 50.8 cm)
FIXED:	Not Available
<b>BACK ANGLE</b> FOLDING:	-8°, -4°, 0° and +4°, +8°
FIXED:	Not Available
<b>BACK UPHOLSTERY:</b>	U850 Black - Adjustable Tension by Straps
<b>SEAT UPHOLSTERY:</b>	U850 Black - Adjustable Tension by Straps
<b>AXLE POSITIONS/CENTER OF GRAVITY:</b>	Adjustable to 4¼ inches (10.8 cm) in two positions: Amputee Position: -2¼ to 2 inches (-5.7 to 5.1 cm) Active Position: 1¼ to 5½ inches (3.2 to 14 cm)
<b>REAR WHEEL AXLE:</b>	Quick Release (Standard), Quad-Release or Titanium (Optional)
<b>REAR WHEEL CAMBER</b> CAMBER TUBE:	0°, 3°, 6°, or 9°
<b>REAR WHEELS</b> REAR WHEEL TYPE:	Sun High performance (Standard), Spinergy SPOX, Spinergy LX, Sun Fusion

<b>REAR WHEEL SIZE:</b>	22, 24 or 25-inch (55.9, 61 or 63.5 cm) (Standard), 26-inch (66 cm) (Optional)
<b>TIRES:</b>	1" Primo High pressure clincher (standard), 1" Kenda, 1" Schwalbe flat resistant, 1 3/8" treaded, 1 3/8" w/flat free inserts, 1" solid, 2" knobby
<b>HANDRIMS:</b>	Aluminum Anodized (Standard) Titanium, Coated, Natural Fit® (Optional)
<b>WHEEL LOCKS:</b>	Push or Pull to Lock (Standard) or Hideaway Undermount (Optional)
<b>FRONT FORKS:</b>	Non-Suspension (Standard), Suspension (Optional)
<b>CASTERS</b>	
CASTER SIZE:	3, 4 or 5-inch (7.6, 10.2 or 12.7 cm)
CASTER TYPE:	Semi-pneumatic (Standard), Soft Roll or Lighted (Optional)
<b>ANTI-TIPPERS:</b>	Optional
<b>WEIGHT:</b>	19.5 lbs (8.8 kg)
<b>SHIPPING WEIGHT:</b>	30 lbs (14 kg)
<b>WEIGHT LIMITATION:</b>	250 lbs (114 kg)

 16 x 16-inch seat, rear wheels and minimal options are included in the weight.



All specifications are approximate.

<b>Crossfire Titanium</b>	
<b>FRAME:</b>	Grade 9 Titanium
<b>FRONT FRAME:</b>	Tapered front end (Standard), V-Style (Optional)
<b>FRONT FRAME ANGLE:</b>	70°, 75°, 80°, 85° or 90°
<b>FOOTREST:</b>	Tubular footrest in same material as frame (Standard), Adjustable Angle NCO, Plastic or Carbon Fiber Cover (Optional)
<b>SEAT HEIGHT</b>	
FRONT:	16 to 21 inches (40.6 to 53.3 cm) (Fixed)
REAR:	14 to 20 Inches (35.6 to 50.8 cm) (Fixed), Ergo Level Seat (Optional)
<b>ARMS (OPTIONAL):</b>	Swing-away Style
<b>SIDE GUARDS (OPTIONAL)</b>	
FOLDING BACK:	Removable, Folding, Removable with Fender
FIXED BACK:	Fixed Aluminum, Fixed Carbon Fiber
<b>SEAT WIDTH:</b>	12 to 18 inches (30.5 to 45.7 cm) (Standard), 19 to 20 inches (48.3 to 50.8 cm) (Optional), Tapered Seat Width (Optional)

### Crossfire Titanium

<b>SEAT DEPTH:</b>	14 to 18 inches (35.6 to 45.7 cm) (Standard), 19 to 20 inches (48.3 to 50.8 cm) (Optional)
<b>BACK STYLE:</b>	Folding (Standard), Fixed (Optional)
<b>BACK HEIGHT</b> ADJUSTABLE:	8 to 11, 10 to 14, 12 to 16, 14 to 18, or 16 to 20 inches (20.32 to 27.94, 25.4 to 35.56, 30.48 to 40.64, 35.56 to 45.72, 40.64 to 50.8 cm)
FIXED:	8 to 16 inches (20.32 to 40.64 cm)
<b>BACK ANGLE</b>	
FOLDING:	-8°, -4°, 0° and +4°, +8°
FIXED:	0°, 3°, 6°, and 9°
<b>BACK UPHOLSTERY:</b>	U850 Black - Adjustable Tension by Straps
<b>SEAT UPHOLSTERY:</b>	U850 Black - Adjustable Tension by Straps
<b>AXLE POSITIONS/CENTER OF GRAVITY:</b>	Adjustable to 4¼ inches (10.8 cm) in two positions: Amputee Position: -2¼ to 2 inches (-5.7 to 5.1 cm) Active Position: 1¼ to 5½ inches (3.2 to 14 cm)
<b>REAR WHEEL AXLE:</b>	Quick Release (Standard), Quad-Release or Titanium (Optional)
<b>REAR WHEEL CAMBER</b> CAMBER TUBE:	0°, 3°, 6°, or 9°

### Crossfire Titanium

<b>Crossfire Titanium</b>	
<b>REAR WHEELS</b>	
REAR WHEEL TYPE:	Sun High performance (Standard), Spinergy SPOX, Spinergy LX, Sun Fusion
REAR WHEEL SIZE:	22, 24 or 25-inch (55.9, 61 or 63.5 cm) (Standard), 26-inch (66 cm) (Optional)
<b>TIRES:</b>	1" Primo High pressure clincher (standard), 1" Kenda, 1" Schwalbe flat resistant, 1 3/8" treaded, 1 3/8" w/flat free inserts, 1" solid, 2" knobby
<b>HANDRIMS:</b>	Aluminum Anodized (Standard), Titanium, Coated, Natural Fit® (Optional)
<b>WHEEL LOCKS:</b>	Push to Lock (Standard) or Hideaway Undermount (Optional)
<b>FRONT FORKS:</b>	Non-Suspension (Standard), Suspension (Optional)
<b>CASTERS</b>	
CASTER SIZE:	3, 4 or 5 inch (7.6, 10.2 or 12.7 cm)
CASTER TYPE:	Semi-pneumatic (Standard), Soft Roll or Lighted (Optional)
<b>ANTI-TIPPERS:</b>	Optional
<b>WEIGHT:</b>	18.5 lbs (8.3 kg)
<b>SHIPPING WEIGHT:</b>	30 lbs (14 kg)
<b>WEIGHT LIMITATION:</b>	250 lbs (114 kg)

 16 x 16-inch seat, rear wheels and minimal options are included in the weight.



All specifications are approximate.

<b>Crossfire All Terrain</b>	
<b>FRAME:</b>	6061T6 Aluminum
<b>FRONT FRAME:</b>	Tapered front end (Standard)
<b>FRONT FRAME ANGLE:</b>	90°
<b>FOOTREST:</b>	Adjustable Angle Footplate (Standard), 2 inch risers (Optional)
<b>SEAT HEIGHT:</b>	Front: 19 to 21 inches (48.26 to 53.34 cm) (Fixed) Rear: 15** to 20 Inches (38.10 to 50.8 cm) (Fixed)
<b>ARMS (OPTIONAL):</b>	Swing-away Style
<b>SIDE GUARDS (OPTIONAL)</b>	
FOLDING BACK:	Removable, Folding, Removable with Fender
FIXED BACK:	Fixed Aluminum, Fixed Carbon Fiber
<b>SEAT WIDTH:</b>	14 to 18 inches (30.48 to 45.72 cm) (Standard), 19 to 20 inches (48.26 to 50.8 cm) (Optional)
<b>SEAT DEPTH:</b>	14 to 18 inches (35.56 to 45.72 cm) (Standard), 19 to 20 inches (48.26 to 50.8 cm) (Optional)
<b>BACK STYLE:</b>	Folding (Standard), Fixed (Optional)
<b>BACK HEIGHT:</b>	No fixed height available.
ADJUSTABLE:	9 to 11, 10 to 14, 12 to 16, 14 to 18, or 16 to 20 inches (20.32 to 27.94, 25.4 to 35.56, 30.48 to 40.64, 35.56 to 45.72, 40.64 to 50.8 cm)
FIXED:	8 to 16 inches (20.32 to 40.64)



<b>BACK ANGLE</b> FOLDING: FIXED:	-15°, -10°, -5°, 0° and 5° 0°, 3°, 6°, and 9°
<b>BACK UPHOLSTERY:</b>	U850 Black - Adjustable Tension by Straps
<b>SEAT UPHOLSTERY:</b>	U850 Black - Adjustable Tension by Straps
<b>AXLE POSITIONS/CENTER OF GRAVITY:</b>	Adjustable to 4¼ inches (10.8 cm) in two positions: Amputee Position: -2¼ to 2 inches (-5.72 to 5.08 cm) Active Position: 1¼ to 5½ inches (3.18 to 13.97 cm)
<b>REAR WHEEL AXLE:</b>	Quick Release (Standard), Quad-Release or Titanium (Optional)
<b>REAR WHEEL CAMBER</b> CAMBER TUBE:	0°, 3°, 6°, or 9°
<b>REAR WHEELS*</b> REAR WHEEL TYPE: REAR WHEEL SIZE:	High Performance with Knobby tires (Standard) Spinergy® Spox (Optional) 24 inch (60.96) or 25 inch (63.5 cm)
<b>HANDRIMS:</b>	Aluminum Anodized (Standard) Titanium, Coated, Natural Fit® (Optional)
<b>WHEEL LOCKS:</b>	Push to Lock (Optional)
<b>FRONT FORKS:</b>	Non-Suspension
<b>CASTERS</b> CASTER SIZE: CASTER TYPE:	8 inch (20.3 cm) Pneumatic (Standard)

<b>ANTI-TIPPERS:</b>	Optional
<b>WEIGHT:</b>	30 lbs (14 Kg)
<b>SHIPPING WEIGHT:</b>	30 lbs (14 kg)
<b>WEIGHT LIMITATION:</b>	250 lbs (114 kg)

 16 x 16 inches (40.64 x 40.64 cm) seat, rear wheels and minimal options are included in the weight.

\*Refer to 3.1 Label Locations, page 17

\*\* 15 inch (38.1 cm) rear seat height only available with 24 inch (60.7 cm) rear wheels.

### 3.3 Component Identification

 Crossfire T7A is shown. The other chairs in the Crossfire Series have similar components.



### 3.4 Tire Pressure Conversion



If equipped with high pressure tires a Presta valve adaptor will be needed to inflate the tires to the recommended pressures below.

PSI rating is printed on the side of the tire.

Conversion formula: 1 psi = 6.895 kPa (approx. 7 kPa).

PSI	KILOPASCALS	PSI	KILOPASCALS
50	345	90	621
55	379	95	655
60	414	100	690
65	448	105	724
70	483	110	758
75	517	115	793
80	552	120	827
85	586		

## 4 Operation

### 4.1 Adjusting/Replacing Standard Footrest



#### WARNING!

- After any adjustments, repair or service and before use, make sure all attaching hardware is tightened securely - otherwise injury or damage may occur.
- ALWAYS perform this procedure in the presence of an assistant. The position of the footrest, camber tube, seat angle, back angle, the tautness of the back upholstery as well as the user's condition are directly related to the wheelchairs stability. Any change to one or any combination of the five may cause the wheelchair to decrease in stability. Use **EXTREME** caution when using a new seating position. The addition of anti-tippers may be required.
- Check ALL allen screws that secure the footrest/raised footrest system to the wheelchair frame to make sure they are securely tightened **BEFORE** using the wheelchair. **ESPECIALLY** if engaging in ANY contact sport.
- The footrest assembly **MUST** be at least 1¼-inches above the ground/floor to avoid hitting protruding objects when using this wheelchair.

1. Loosen the allen screw of the two clamps **A** that secure the footrest **B** to the wheelchair frame **C**.

#### Replacing the Footrest

1. Remove existing footrest.
2. Install new footrest **B**.

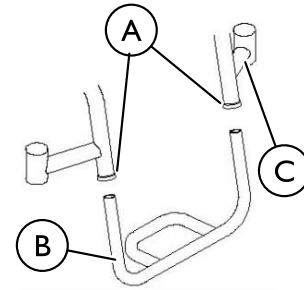

#### WARNING!

- The standard footrest has an open hoop. A footplate cover is recommended for wheelchair users that have leg spasticity or whose feet have a possibility of falling through the footrest hoop. A calf strap is provided with each wheelchair to prevent the feet from slipping backwards off of the footrest. Be sure the calf strap is secure when using the wheelchair.

#### Adjusting the Footrest

1. Position new/existing footrest **B** to desired height.
2. Tighten the allen screw of the two clamps **A** that secure the footrest **B** to the wheelchair frame **C**.

### 4.2 Replacing/Adjusting Optional Adjustable Angle Footrest



A footrest for short leg lengths is available as an option. It has an adjustable footplate with 2 inch spacers and longer mounting screws that attach the footrest to the footrest tube.

## Replacing the Footrest

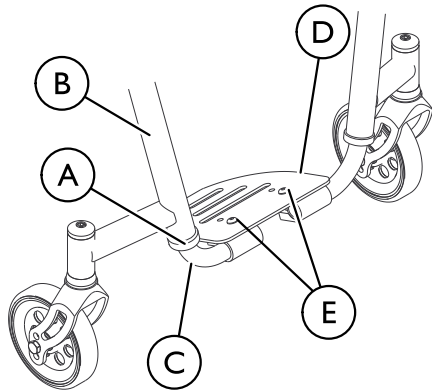

1. Loosen, but do not remove the allen screw of the two clamps (A) that secure the footrest to the wheelchair frame (B).
2. Slide the existing footrest tubes (C) out of the wheelchair frame (B) and install new footrest by reversing this step.
3. Position the new footrest to a determined height.
4. Tighten the allen screw of the two clamps (A) that secure the footrest to the wheelchair frame (B).
5. Adjust the footplate (D) to the desired position.

## Adjusting Footplate Angle

1. Loosen, but **DO NOT** remove the two mounting screws (E) and locknuts (not shown) that secure the footplate (D) to the two footrest tubes (C).
2. Position the footplate (D) to the necessary angle to accommodate the user.
3. Retighten the two mounting screws (E) and locknuts.

 The locknuts should lie in the channel of the footplate clamp.

## Adjusting Footplate Depth

1. Remove the two mounting screws (E) and locknuts (not shown) that secure the footplate (D) to the footrest tubes (C).

 Observe the angle of footplate (D) for reinstallation.

2. Move the footplate (D) to one of two mounting positions (F) to accommodate the user.
3. Using the two mounting screws (E) and locknuts, secure the footplate (D) to the footrest tubes (C).

 The locknuts should lie in the channel of the footplate half clamp.

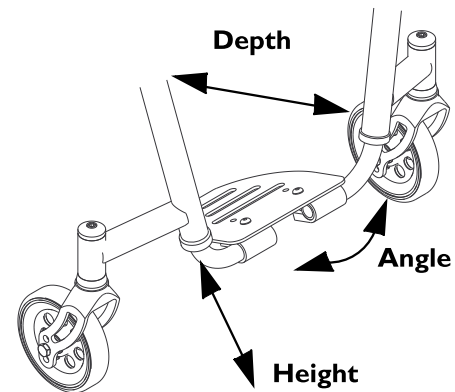

### 4.3 Unfolding/Folding the Back



#### WARNING!

- ALWAYS perform these procedures in the presence of an assistant. The position of the footrest, camber tube, seat angle, back angle, the tautness of the back upholstery as well as the user's condition are directly related to the wheelchairs stability. Any change to one or any combination of the five may cause the wheelchair to decrease in stability. Use **EXTREME** caution when using a new seating position. The addition of anti-tippers may be required.
- After ANY adjustments, repair or service and **BEFORE** use, make sure all attaching hardware is tightened securely - otherwise injury or damage may occur.



#### WARNING!

- After unfolding the back, ensure that the plunger pins are fully engaged in the mounting holes of the adjustment square in the back cane mounting brackets (Detail “A”). Back **MUST** be locked securely in place. Otherwise, serious injury could result.

#### DETAIL “A” — FOLDING THE BACK

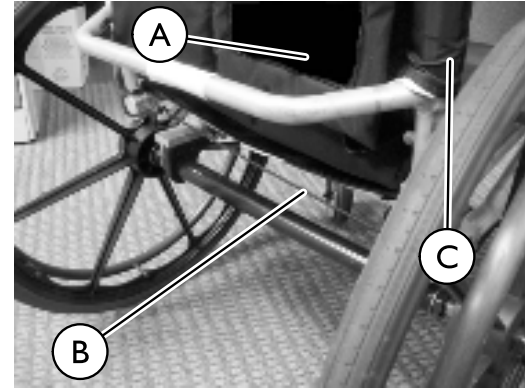

1. To fold the back **A**, pull up on the back release cord **B** and push the back **A** toward the seat **C** of the wheelchair (Detail “A”).
2. To unfold the back **A**, pull up on the back release cord **B** and lift the back **A** away from the seat **C** until the back locks into place (Detail “B” and Detail “C”).



An audible “click” will be heard when the plunger pins fully engage into the adjustment square **A** (Detail “C”) and the split ring will be flush up against the back stop insert.

The back should have a small amount of movement when locked in the open position. Plunger pins should snap in and release easily without resistance.

## DETAIL “B” — UNFOLDING THE BACK

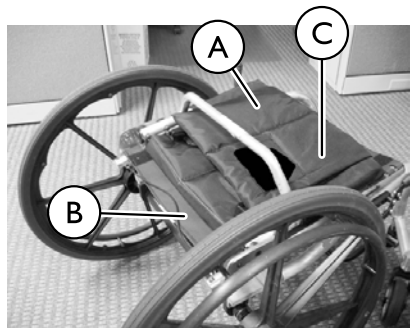

DETAIL “C”



## 4.4 Back Angle Adjustment



The numbers in the recess of the back angle plate are intended to define the resulting back angle of a chair that has 2 inch (5.08 cm) seat drop [at 17 inch (43.18) depth] and that is measured relative to true vertical with the chair sitting on a level surface. The plus (+) sign increases the back angle and the minus (-) sign decreases the back angle. The resulting back angle will vary somewhat depending on your chair configuration. Refer to chart to see these settings converted into back angle relative to the seat.

Perform this procedure on both sides of the wheelchair at the same time.

DETAIL “A”

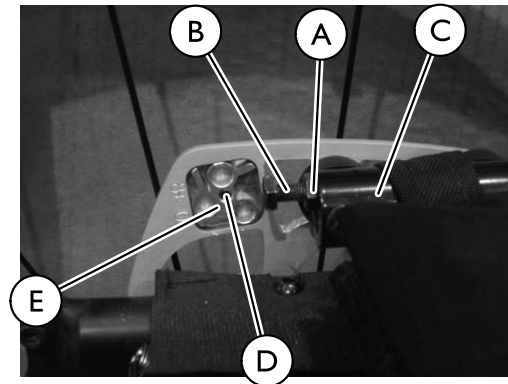

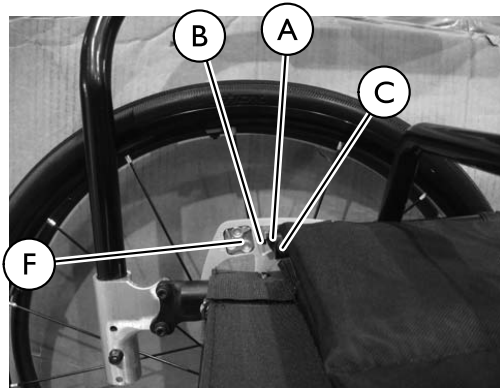

1. Fold down the back. Refer to 4.3 Unfolding/Folding the Back, page 31.
2. Loosen the jam nut **A** on the placement screw **B** located at the bottom of the back cane **C** (Detail "A").

**DETAIL "B"**

3. Tighten the placement screw **B** so that the screw and jam nut **A** are snug against the bottom of the back cane **C** (Detail "B").

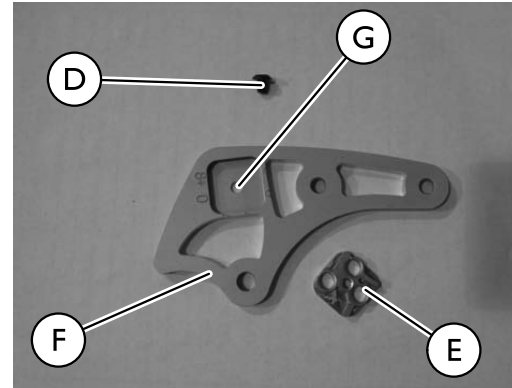
**DETAIL "C"**

4. Remove the mounting screw **D** that secures the adjustment square **E** to the back angle plate **F** (Details "A" and "C").
5. Remove the adjustment square **E** from the recess of the back angle plate **F** (Detail "C").

**i** Note the hole on the adjustment square. When the hole is positioned on top of the number inside the recess, this number represents the back angle relative to true vertical. One side of the adjustment square provides back angles of -8°, 0° and -4°. Flip the adjustment square over to obtain back angles of 8°, 4° and 0° .



**WARNING!**

– If the adjustment square ⑤ is installed into the recess of the back angle plate ⑥ so that the adjustment square hole is not on top of a number, **DO NOT** use this position. Otherwise, injury will occur. When the adjustment square hole is not on top of a number, it prevents the locking pins from locking into position when the back is raised.

6. Position the adjustment square ⑤ in the recess of the back plate ③ with the hole located aligned with a number .
7. Secure the adjustment square ⑤ to the back angle plate ⑥ with the mounting screw ④. Tighten securely.
8. Repeat STEPS 2-6 for remaining back cane ③.



**WARNING!**

– After unfolding the back, ensure that the plunger pins are fully engaged in the mounting holes of the adjustment square in the back angle plates (Detail “A”). Otherwise, serious injury could result.

9. Unfold the back until the plunger pins lock into the mounting holes in the adjustment square ③.

**DETAIL “D”**

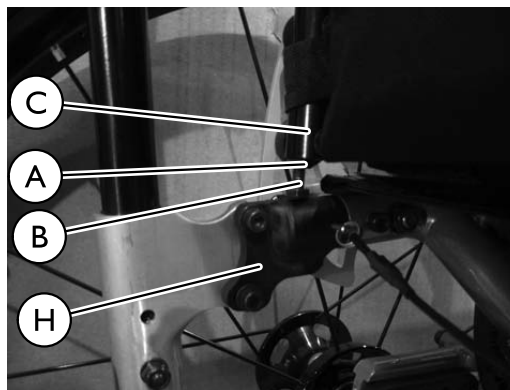

10. Unthread the placement screw ⑧ until head of screw rests on seat rail ⑨ (Detail “D”).
11. Completely tighten jam nut ⑦ up against bottom of back cane ③ (Detail “D”).

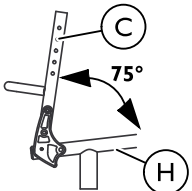
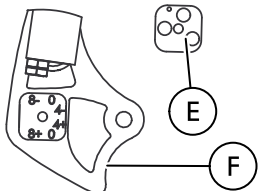
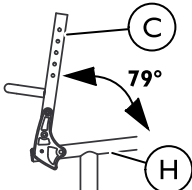
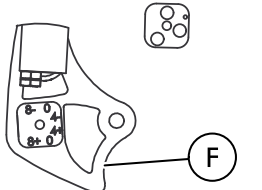
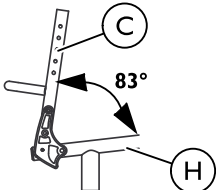
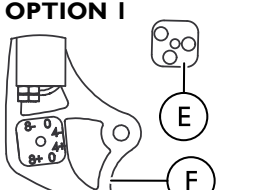
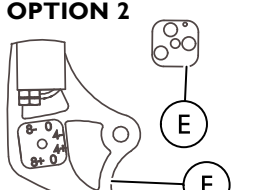

When adjusted properly, the back should have a small amount of movement when locked in the open position. Plunger pins should snap in and release easily without resistance.

DESIRED SEAT ANGLE	ADJUSTMENT SQUARE POSITION			
	NUMERICAL	GRAPHICAL		
	-8°		<p>Hole in adjustment square will align with 8- when installed in this orientation.</p>	
	-4°		<p>Hole in adjustment square will align with 4- when installed in this orientation.</p>	
	0°	<p><b>OPTION 1</b></p> 	<p>Hole in adjustment square will align with 0° when installed in this orientation.</p>	<p><b>OPTION 2</b></p> 

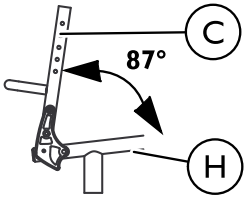
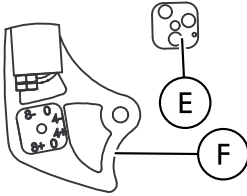
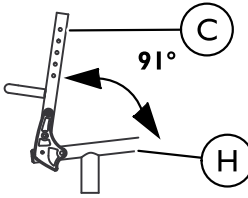
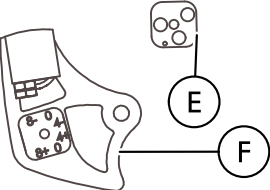
	<p>+4°</p>	<p>Hole in adjustment square will align with 4+ when installed in this orientation.</p>	
	<p>+8°</p>		<p>Hole in adjustment square will align with 8+ when installed in this orientation.</p>

## 4.5 Adjustable Tension Back Upholstery



### WARNING!

- ALWAYS perform these procedures in the presence of an assistant. The position of the footrest, camber tube, seat angle, back angle, the tautness of the back upholstery as well as the user's condition are directly related to the wheelchairs stability. Any change to one or any combination of the five may cause the wheelchair to decrease in stability. Use EXTREME caution when using a new seating position. The addition of anti-tippers may be required.

### The Back Upholstery Cover



**The back upholstery cover is designed for three reasons:**

- The first is as a modesty cover.
- The second is to keep the cushion from sliding out of the back of the wheelchair.
- The third is a sacral support depending upon how far or tight the flap is pulled under the seat cushion.
- The adjuster fastening straps can be adjusted at various levels of tension to accommodate individual end-users.

### Adjusting the Tautness of the Back



- The adjustable tension back upholstery consists of an upper and lower (lumbar) section.

To adjust the back tension, perform the following:

1. Lift back upholstery cover up and flip over toward front of wheelchair.
2. Tighten or loosen the adjuster fastening straps (A).

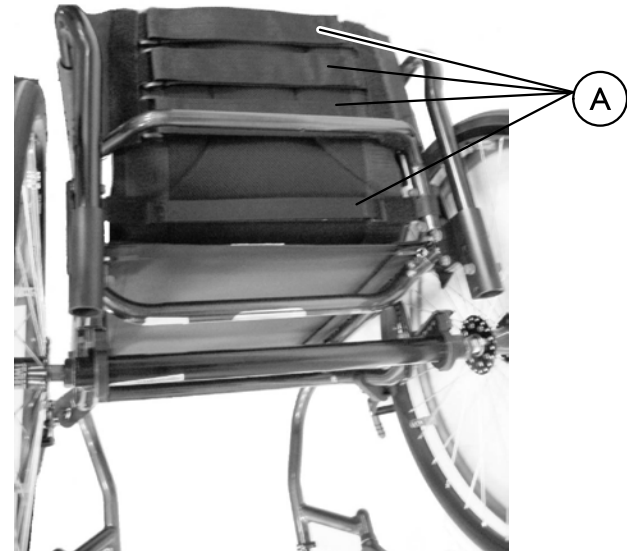

## Removing/Installing the Back Upholstery Cover, Adjustable Tension Back Upholstery and Lumbar Strap



– If replacing the back upholstery cover, adjustable tension back upholstery and/or lumbar strap, remove the existing upholstery/lumbar strap and install the new upholstery/lumbar strap.

### Removing the Back Upholstery Cover

1. Remove the seat cushion, if applicable.
2. Pull the back upholstery cover **A** away from the adjustable tension back upholstery **B** separating the fastening strips of the back upholstery cover **C** from the fastening strips of the adjustable tension back upholstery and seat **D** (Details “A” and “B”).
3. Remove back upholstery cover **A** from wheelchair.

DETAIL “A”

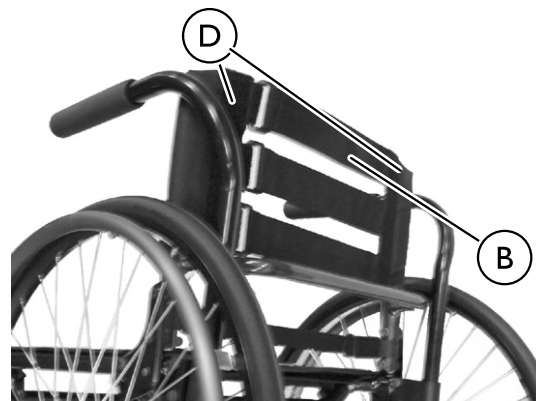

DETAIL “B”

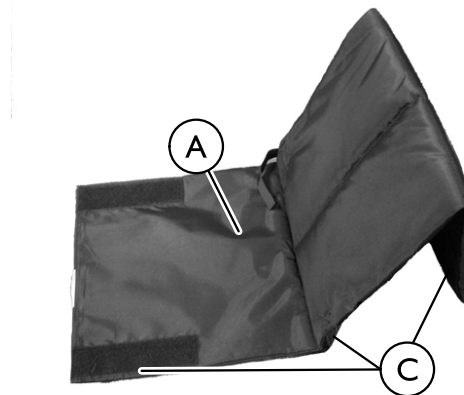

### Removing the Adjustable Tension Back Upholstery

1. Remove the back upholstery cover (A).
2. Slide adjustable tension back upholstery (B) off back canes (E) (Details "C" and "D").

DETAIL "C"

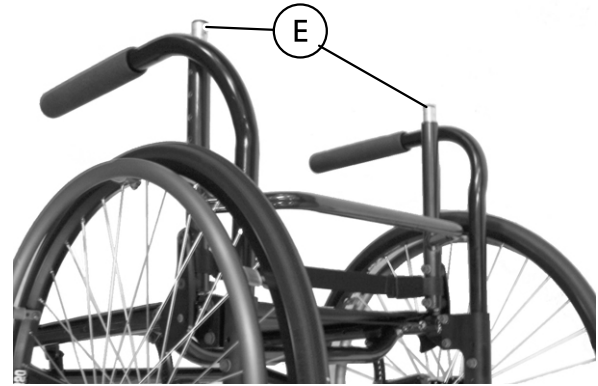

DETAIL "D"

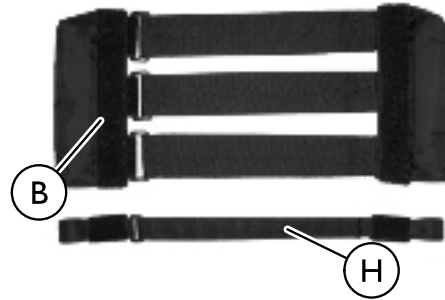

### Removing the Lumbar Strap

1. Remove the back upholstery cover (A).
2. Fold back forward. Refer to 4.3 Unfolding/Folding the Back, page 31.
3. Loosen the top mounting screw (F) but DO NOT remove (Detail “E”).
4. Remove the lower mounting screw, covered spacer, washer and locknut (G) from each back cane (E) (Detail “E”).
5. Slide lumbar strap (H) off back canes (E) (Details “D” and “E”).

### Installing the Lumbar Strap

1. Install lumbar strap (H) (Details “D” and “E”).
2. Install lower mounting screw, covered spacer, washer and locknut (G) onto each back cane (E) (Detail “E”).
3. Tighten the top (F) and bottom mounting screws (G) (Detail “E”).
4. Return back to upright position. Refer to 4.3 Unfolding/Folding the Back, page 31.
5. Install the back upholstery.

DETAIL “E”

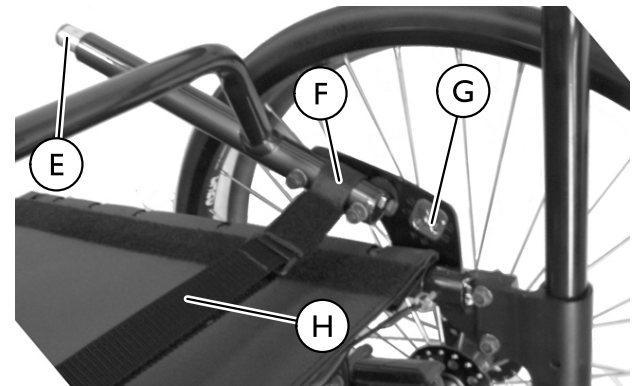



### Installing the Adjustable Tension Back Upholstery

- I. Install the adjustable tension back upholstery ⑥ onto the back canes ⑤ (Details “D”, “F”, and “A”).

### Installing the Back Upholstery Cover

- I. Install back upholstery cover ⑦ onto the adjustable tension back ensuring the fastening strips on the back upholstery cover ③ are aligned with the fastening strips of the adjustable tension back and seat ④ (Detail “F”).

**DETAIL “F”**

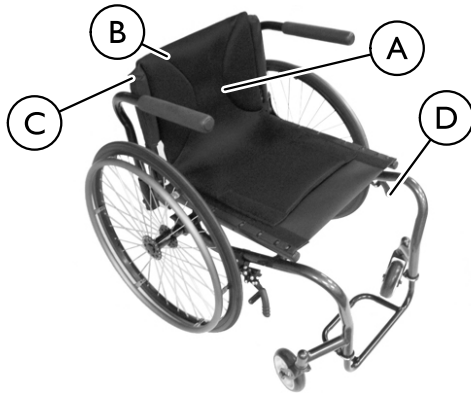

## 4.6 Back Height Adjustment

 Observe the tautness of the back upholstery for reinstallation.

1. Remove the back upholstery cover and adjustable tension back upholstery. Refer to 5.3 Removing/Installing Foldover Back Upholstery, page 61 and 4.5 Adjustable Tension Back Upholstery, page 37 .



### WARNING!

- Adjustment pin **A** MUST be protruding through hole in back cane.
- Ensure that both back cane inserts **B** are at the same height BEFORE reassembling the wheelchair.

2. Press the adjustment pin **A** on the back cane insert tube **B** in and adjust the back height to one of four heights on the back cane **C** depending on original back height:

HOLE* NUM- BER	BACK HEIGHT (IN INCHES)				
	8-11	10-14	12-16	14-18	16-20
1	8	10	12	14	16
2	9	11	13	15	17
3	10	12	14	16	18
4	11	13	15	17	19
5	N/A	14	16	18	20



– \*Holes numbered from bottom to top for reference only. (There are no numbers on the back canes **C**.)

3. Reinstall the back upholstery cover and adjustable tension back upholstery. Refer to 5.3 Removing/Installing Foldover Back Upholstery, page 61 and 4.5 Adjustable Tension Back Upholstery, page 37.
4. Check the tautness of the back.

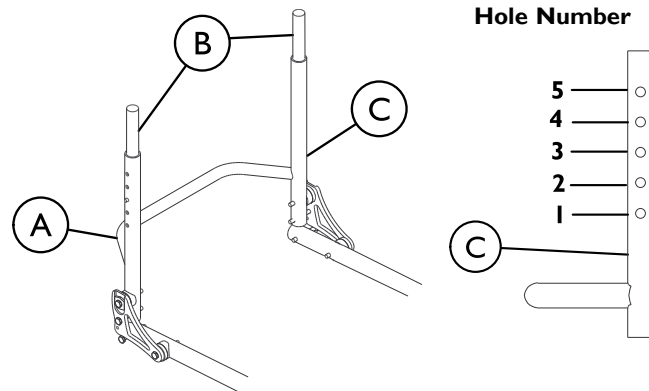

## 4.7 Adjusting Quick-Release Axles

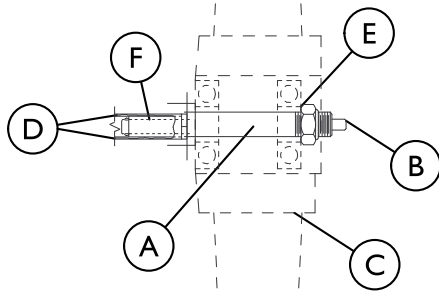

1. Remove rear wheel and quick-release axle **A** from the wheelchair. Refer to 5.7 Removing/Installing Rear Wheels, page 65.
2. Depress detent pin **B** in the quick-release axle **A** and slide axle through the wheel hub **C**.
3. Release detent pin **B** ensuring that the locking pins **D** are fully released.
4. Increase or decrease end play by adjusting the locknut **E** on the end of the quick-release axle **A**.
5. Reinstall rear wheel onto the wheelchair. Refer to 5.7 Removing/Installing Rear Wheels, page 65.

 End of Quick Release axle **A** is shown for reference only. It is not visible when inserted into cambar bar **F**.

## 4.8 Adjusting Quad-Release Handles In and/or Out

### Adjusting Quad-Release Handle In and/or Out

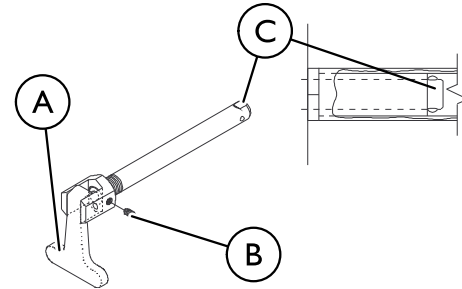

1. Remove rear wheel and the quad-release axle from the wheelchair. Refer to 5.7 Removing/Installing Rear Wheels, page 65.
2. Loosen the locking screw **B**.
3. Make one or both of the following adjustments:
  - If the quad-release handle **A** is not releasing the locking pins **C** completely, rotate the quad-release handle **A** approximately one-quarter turn clockwise.
  - If the quad-release handle **A** hits the spokes of the rear wheel when assembled, rotate the quad-release handle **A** approximately one-quarter turn counterclockwise.
4. Tighten the locking screw **B**.
5. Reinstall the rear wheel and quad-release axle onto the wheelchair. Refer to 5.7 Removing/Installing Rear Wheels, page 65.

6. Flip the handle of the quad-release axle down to release the detent pin ensuring that the locking pins © are fully released.
7. Repeat the above procedures until the quad-release axle locks correctly.

## 4.9 Removing Play from Rear Wheels

### Removing Play from Rear Wheels

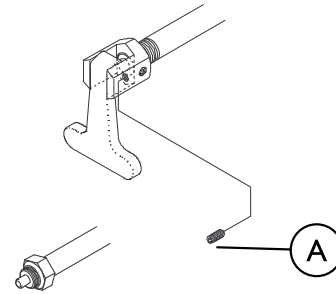

- I. With the rear wheel and quad-release axle still mounted onto the wheelchair, make the following adjustment:
  - Tighten the length adjusting screw Ⓐ until there is no in and out movement of the quad-release axle and rear wheel.

## 4.10 Adjusting Wheelbase Length, Adjusting Center of Gravity (COG)



### WARNING!

– ALWAYS perform this procedure in the presence of an assistant. The position of the footrest, camber tube, seat angle, back angle, the tautness of the back upholstery as well as the user's condition are directly related to the wheelchairs stability. Any change to one or any combination of the six may cause the wheelchair to decrease in stability. Use **EXTREME** caution when using a new seating position. The addition of anti-tippers may be required.



Measure the distance between the center of the front caster (A) and the center of the rear wheel (B) to determine the new wheelbase length (C). The wheelbase length (C) can be adjusted in one or more of the following combinations:

Repositioning the camber tube clamps.

Repositioning the camber tube clamps socket screws.

Reversing the camber tube clamps direction.





- I. Refer to the chart on the following pages to determine the adjustments necessary to achieve the desired wheelbase length.

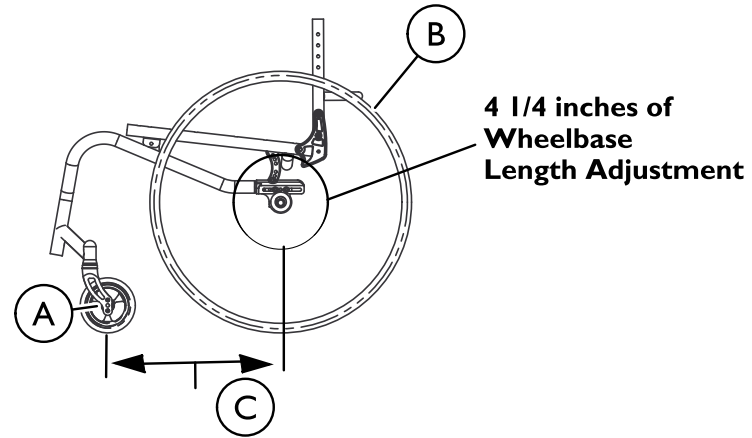

### CAUTION!

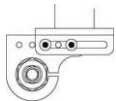
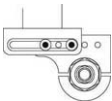
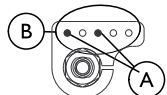
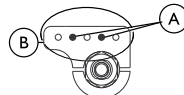
– Ensure one empty mounting position (B) remains between the two socket screws (A), otherwise damage to the wheelchair may occur.

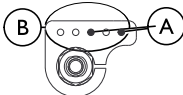

<p align="center"><b>SOCKET SCREW MOUNTING POSITIONS</b></p>	
<p align="center">CAMBER TUBE CLAMP FACING THE FRONT OF THE WHEELCHAIR</p>	<p align="center">CAMBER TUBE CLAMP FACING THE REAR OF THE WHEELCHAIR</p>
<p><b>Front of Wheelchair</b></p> <p><i>NOTE: Camber tube clamp shown in forward most position.</i></p> 	<p><b>Rear of Wheelchair</b></p> <p><i>NOTE: Camber tube clamp shown in rear most position.</i></p> 
	
	
	

## 4.1 I Reposition the Camber Tube

1. Remove the rear wheels. Refer to 5.7 Removing/Installing Rear Wheels, page 65.
2. Loosen, but DO NOT remove, the four socket screws and washers (A) that secure the two camber tube clamps (B) to the camber tube supports (C).
3. Slide the camber tube (D) forward or backward to adjust the wheelbase length to the desired position.

**i** Ensure that both camber tube clamps (B) are adjust to the same position in the camber tube support (C). This will ensure that the camber tube (D) remains at 90° to each side frame.

4. Securely tighten the four socket screws and washers (A) that secure the two camber tube clamps (B) to the camber tube supports (C).
5. Install the rear wheels. Refer to 5.7 Removing/Installing Rear Wheels, page 65.

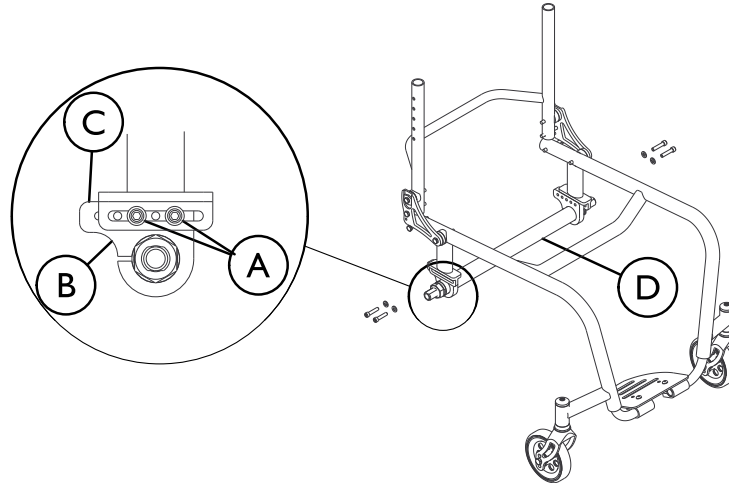

## 4.12 Repositioning the Camber Tube Clamp Socket Screws

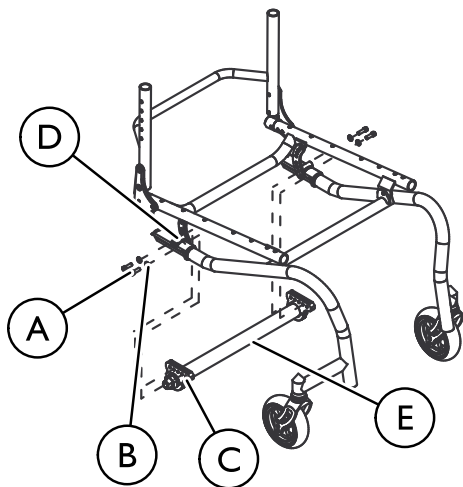

1. Remove the rear wheels. Refer to 5.7 Removing/Installing Rear Wheels, page 65.
2. Refer to Socket Screw Mounting Positions in 4.10 Adjusting Wheelbase Length, Adjusting Center of Gravity (COG), page 45 to determine which socket screw(s) **A** **MUST** be moved and to which mounting positions.
3. Remove the four socket screws **A** and washers **B** from both camber tube clamps **C**.
4. Align the desired mounting positions of the camber tube clamps **C** with the opening of the camber tube supports **D**.



### CAUTION!

– Ensure one empty mounting position remains between the two socket screws **A**, otherwise damage to the wheelchair may occur.

5. Install the four socket screws **A** and washers **B** into the desired mounting positions of both camber tube clamps **C**. Hand tighten.



Ensure that both camber tube clamps **C** are adjust to the same position in the camber tube support **D**. This will ensure that the camber tube **E** remains at 90° to each side frame.

6. Slide the camber tube **E** forward or backward to adjust the wheelbase length to the desired position. Securely tighten the four socket screws **A**.
7. Install the rear wheels. Refer to 5.7 Removing/Installing Rear Wheels, page 65.



### 4.13 Adjusting Wheelbase Width



Perform this procedure on one side of the wheelchair at a time for ease of adjustment.

The wheelbase width can be increase/decreased by 3/4 per side = 1 and 1/2 inch (3.81 cm) total range of adjustment.

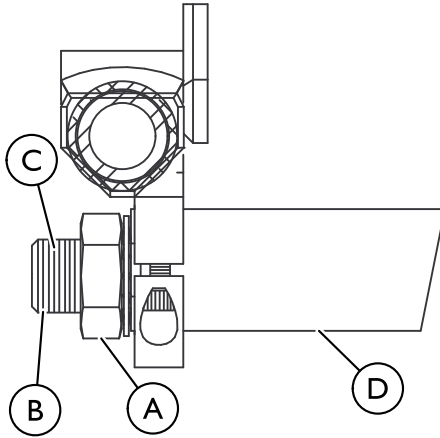

1. Remove the rear wheels. Refer to 5.7 Removing/Installing Rear Wheels, page 65.
2. Loosen the axle nut (A) and rotate axle bushing (B) to increase/decrease the wheelbase width.
3. Securely tighten axle nut (A). Torque nut (A) to 30-35 ft.-lbs (9.14–10.67m-kg).
4. Count the number of threads (C) showing on the axle bushing (B).



#### **WARNING!**

– ALWAYS leave 3/4 inch (1.9cm) of axle bushing (B) engaged into camber tube (D) otherwise damage and/or injury may occur.



– The number of threads (C) showing on the axle bushing (B) should be equal on both sides of the wheelchair. Otherwise, wheelchair performance may be affected.

5. Repeat steps 2-3 for the opposite axle bushing (B).
6. Install the rear wheels. Refer to 5.7 Removing/Installing Rear Wheels, page 65.

## 4.14 Adjusting the Camber Tube



### WARNING!

– Camber tube clamps - Make sure the clamp screws are securely tightened before using the wheelchair, otherwise injury or damage to the wheelchair may occur.



Stand behind the wheelchair to determine left or right.

### DETAIL “A” — SIDE VIEW

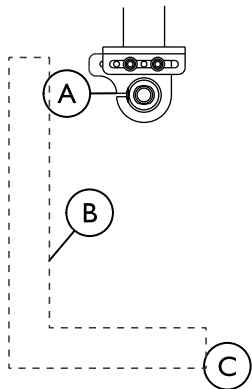

1. Loosen, but DO NOT remove, the socket head clamp screws in the camber tube clamps (Detail “A”).
2. Using an “L” square (B), rotate the axle tube until the flat edge of the camber tube (A) is at a 90° angle with the ground/floor (C).



Ensure camber tube is centered between clamps (A).

This adjustment is made with the rear wheels attached to the chair and all four wheels contacting the floor (C).

If camber tube is not 0° degrees, then it MUST be rotated so that the axle bushings are angled up at their ends.

3. Securely tighten the socket screw in the camber tube clamps (Detail “A”).
4. Determine the toe in/toe out of the wheelchair. Refer to 4.15 Determining/Setting Toe In/Toe Out, page 51 .

## 4.15 Determining/Setting Toe In/Toe Out

1. Inflate all pneumatic tires to recommended tire pressures (listed on the sidewall of the tire).
2. Measure the distance between the centerlines **A** at the rear and front of the rear wheels at approximately 12 inches (30.48cm) [for 24-inch (60.96cm)diameter wheels] from the ground/floor **B**.
3. Determine difference between two measurements. If difference between the two measurements is greater than 1/8 inch, one of two conditions exists:
  - If the back centerline measurement of the rear wheels **C** is **SMALLER E** than the front centerline measurement of the rear wheels **D**, a **TOE-OUT F** condition exists
  - If the back centerline measurement of the rear wheels **C** is **LARGER G** than the front centerline measurement of the rear wheels **D**, a **TOE-IN H** condition exists
4. If the difference between the measurements is greater than 1/8-inch (0.32cm), correct the toe-in/toe-out condition by performing the following:
  - a. Loosen both mounting socket head clamp screws
  - b. Rotate the camber tube until front and rear measurement are within 1/8-inch
  - c. Securely tighten both socket head clamp screws

**Top View of Wheelchair**

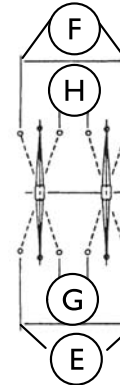
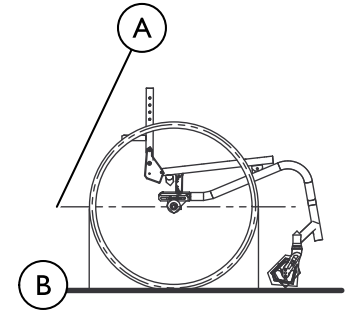
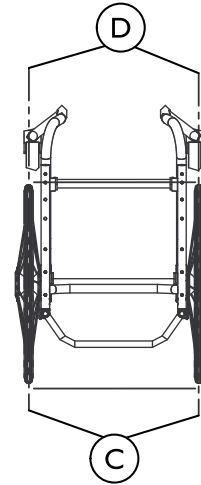

**Top View of Wheelchair**

## 4.16 Adjusting Fork Tension

1. To properly tighten forks and guard against flutter, perform the following check on both forks.
  - a. Tip back the wheelchair to floor.
  - b. Pivot both forks and casters to top of their arc simultaneously.
  - c. Let casters drop to bottom of arc (wheels should swing once to one-side, the IMMEDIATELY rest in a straight, downward position).
2. If necessary, perform one of the following to adjust the fork tension.
  - Standard Forks — Adjust locknut according to freedom of caster swing (Detail “A”).
    - a. Tighten locknut **A** to reduce caster **B** swing.
    - b. Loosen the locknut **A** to increase caster **B** swing.

- Suspension Fork (Detail “B”)
    - a. Refer to 5.14 Removing/Installing the Elastomers (Suspension Forks Only), page 74 to remove the elastomer and suspension fork bottom to access the locknut.
    - b. No tension adjustment can be performed on this fork.
    - c. Refer to 5.14 Removing/Installing the Elastomers (Suspension Forks Only), page 74 to secure the suspension fork top to the elastomer and suspension fork bottom.
  - One Sided Fork (Detail “D”)
    - a. No tension adjustment can be performed on this fork.
3. Test wheelchair for maneuverability.
  4. If necessary, repeat STEPS 1–2 to adjust locknuts until tension is correct for both forks.

**DETAIL “A”  
STANDARD FORK**

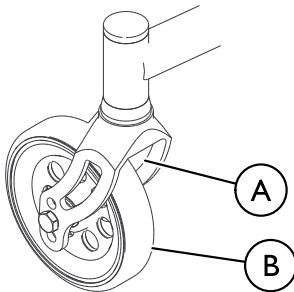

**DETAIL “B”  
SUSPENSION FORK**

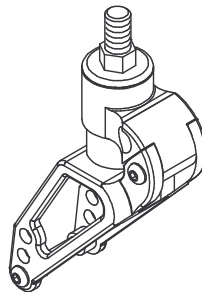

**DETAIL “C” — ONE  
SIDED FORK**

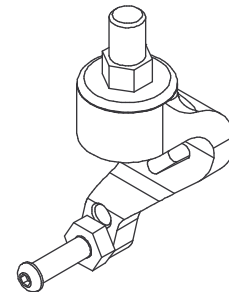

## 4.17 Changing Wheel Lock Handle Position

1. Loosen, but do not remove, the rear handle mounting screw (A).
2. Remove the front handle mounting screw and locknut (B).
3. Align the front handle mounting hole with one of three desired mounting positions (C) on the wheel lock.
4. Using the front handle mounting screw and locknut (B), secure the handle (D) to the wheel lock.
5. Securely tighten the front and rear handle mounting screws and locknuts (A), (B).
6. Repeat steps 1-5 on remaining wheel lock handle (D).

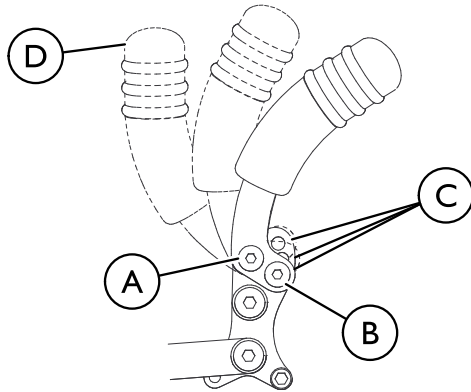

## 4.18 Converting Wheel Lock From Push-to-Lock or Pull-to-Lock

### Converting From Push-to-Lock to Pull-to-Lock

#### DETAIL “A” WHEEL LOCK IN PUSH-TO- LOCK CONFIG- URATION

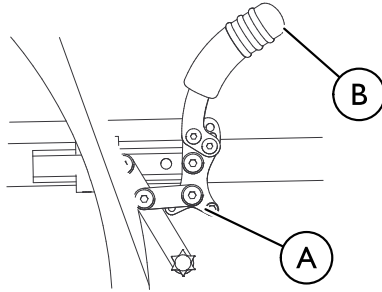

1. Remove set screw **A** from the lower stop position (Detail “A”).
  - i** As the wheel lock handle **B** is pushed downwards, the wheel lock will engage and then disengage the wheel.
2. Push wheel lock handle **B** down to access the upper stop position (Detail “B”).
3. Install set screw **A** into upper stop position.
4. Pull wheel lock handle **B** up to engage wheel lock. If wheel lock does not properly engage the wheel, refer to 5.15 Replacing/Adjusting the Wheel Locks, page 75.

### Converting From Pull-to-Lock to Push-to-Lock

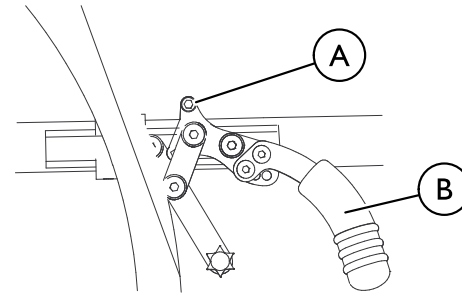

#### DETAIL “B” WHEEL LOCK IN PULL-TO- LOCK CON- FIGURA- TION

1. Remove set screw **A** from the upper stop position (Detail “B”).
  - i** As the wheel lock handle **B** is pulled upwards, the wheel lock will engage and then disengage the wheel.
2. Pull wheel lock handle **B** up to access the lower stop position (Detail “A”).
3. Install set screw **A** into lower stop position.
4. Push wheel lock handle **B** down to engage wheel lock. If wheel lock does not properly engage the wheel, refer to 5.15 Replacing/Adjusting the Wheel Locks, page 75.

## 4.19 Adjusting/Replacing Anti-tipper



### WARNING!

- After ANY adjustments, repair or service and BEFORE use, make sure all attaching hardware is tightened securely - otherwise injury or damage may occur.



### WARNING!

- Anti-tippers must be attached at all times. Inasmuch as the anti-tippers are an option on this wheelchair (you may order it with or without the anti-tippers), Invacare strongly recommends ordering the anti-tippers as an additional safeguard for the wheelchair user.
- Anti-tippers must be fully engaged. Ensure the lock buttons of the anti-tippers fully protrudes out of the mounting hole in the anti-tipper bracket.
- Ensure both anti-tippers are adjusted to the same height.



Measurements for anti-tippers are approximate and are taken using the top adjustment hole on the anti-tipper (Detail “A”).

## Adjusting Anti-Tipper



### WARNING!

- When anti-tippers are used, anti-tippers MUST be adjusted to maintain a 1-1/2 to 2-inch clearance between the bottom of the anti-tipper wheels and the ground/ floor. This spacing should ALWAYS be checked whenever adjustments/changes are made to the wheelchair. Failure to maintain proper spacing may result in the chair tipping over backward causing serious injury or property damage.

1. Press in the lock button **C** that secures the anti-tipper wheel assembly to the anti-tipper bar **E**.
2. Adjust the height of the anti-tipper wheels to between 1-1/2 and 2-inches **G** of the ground/floor **D**.
3. Repeat STEPS 1-2 for the opposite anti-tipper **B**.

## Replacing Anti-Tipper



### WARNING!

- When anti-tippers **B** are used, anti-tippers **B** MUST be adjusted to maintain a 1-1/2 to 2-inch clearance **G** between the bottom of the anti-tipper wheels and the ground/floor **D**. This spacing should ALWAYS be checked whenever adjustments/changes are made to the wheelchair. Failure to maintain proper spacing may result in the chair tipping over backward causing serious injury or property damage.

1. Press in the release button **A** that secures the existing anti-tipper **B** to the anti-tipper bracket **H** and remove the anti-tipper **B** from the anti-tipper bracket **H**.
2. Insert the new anti-tipper **B** into the anti-tipper bracket **H** until lock buttons **C** protrude out of mounting hole **F**.

3. Press in the lock button on the anti-tipper bar (E) and install the anti-tipper wheels onto the new anti-tipper bar (E).
4. Repeat STEPS 1-3 for the opposite anti-tipper (B).

5. Measure the distance between the bottom of the anti-tipper wheels and the ground/floor (D).
6. If necessary, adjust the height of the anti-tippers (B). Refer to 4.19 Adjusting/Replacing Anti-tipper, page 55.

**DETAIL “A” —  
ANTI-TIPPER  
ADJUSTMENT  
HOLES**

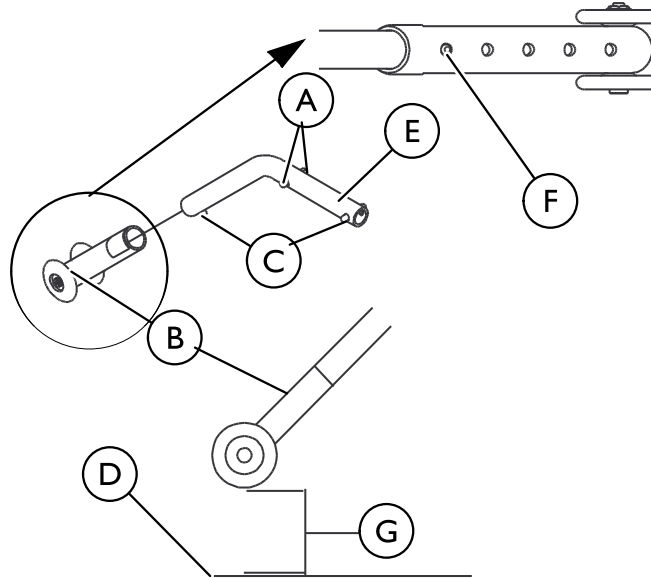



### ANTI-TIPPERS USED WITH HIGH SEAT TO FLOOR HEIGHTS

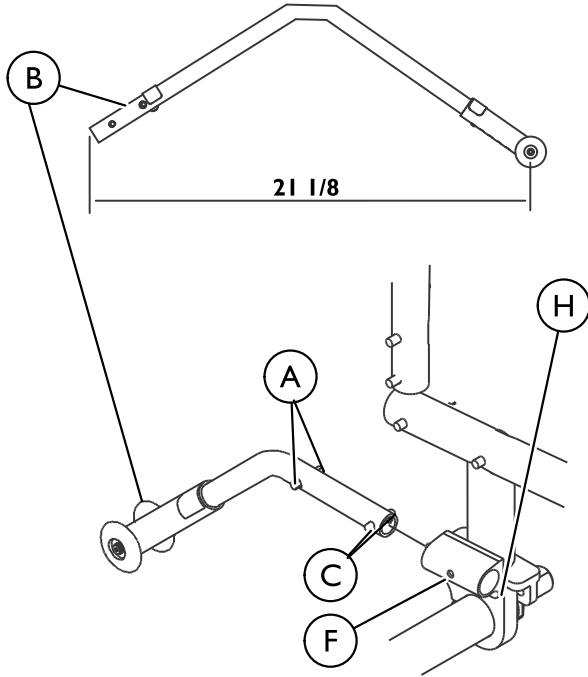

### ANTI-TIPPERS USED WITH LOW SEAT TO FLOOR HEIGHTS

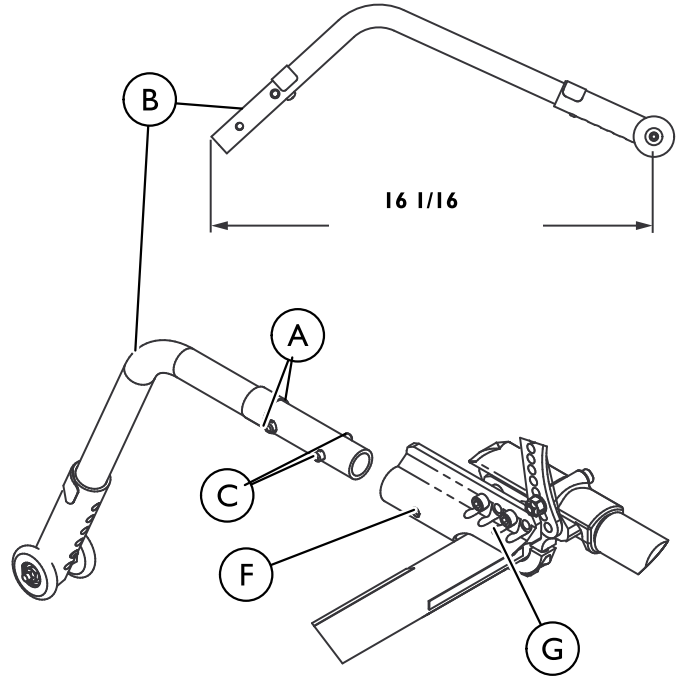

## 5 Service

### 5.1 Installing the Swingaway Padded Armrest Socket



#### WARNING!

- After any adjustments, repair or service and before use, make sure all attaching hardware is tightened securely - otherwise injury or damage may occur.
- Do not attempt to lift or tilt a wheelchair by using any removable (detachable) parts. Lifting by means of any removable (detachable) parts of a wheelchair may result in injury to the user or damage to the wheelchair.

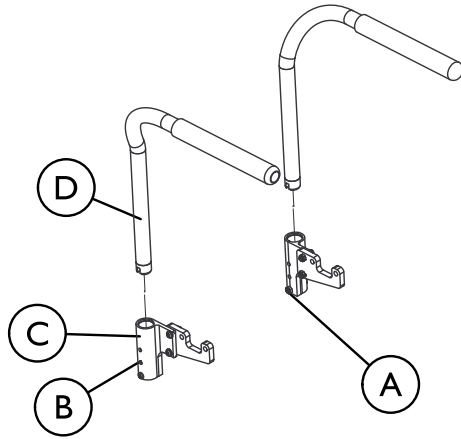

1. Remove or fold down the back. Refer to 5.4 Removing/Installing the Back Frame, page 62.
2. Insert mounting bolt (A) into the mounting hole (B) at the desired height on the swingaway padded armrest socket (C) and secure with the locknut.
3. Install the swingaway padded armrest (D). Refer to 5.2 Installing/Removing/Adjusting the Swingaway Padded Armrest, page 60.

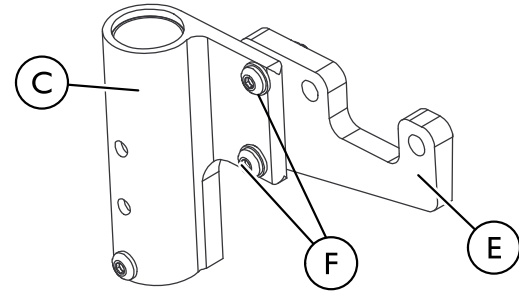

4. Attach the left and right swingaway arm mounting hardware (E) to the swingaway padded armrest sockets (C) using the four mounting screws and locknuts (F). Tighten securely.

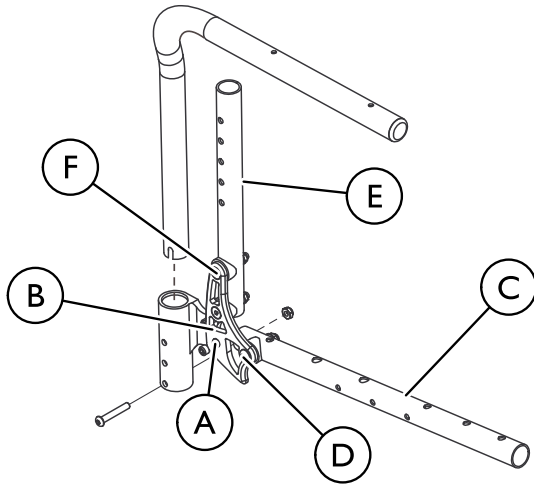

5. Insert the mounting screw **A** through the lock-down folding back latch **B** and the swingaway arm mounting hardware (not shown). Tighten securely.
6. Attach the wheelchair frame **C** to the lock-down folding back latch **B** using the spring pin assembly **D**.
7. Attach backframe **E** to the lock-down folding back latch **B** using the two mounting screws and locknuts **F**.
8. Install the back. Refer to 5.4 Removing/Installing the Back Frame, page 62.

## 5.2 Installing/Removing/Adjusting the Swingaway Padded Armrest

### Installing the Swingaway Padded Armrest

1. Secure mounting bolt (A) and locknut (B) in desired mounting hole (C). Tighten securely.
2. Insert swing away padded armrest (D) into armrest socket (E) so that notch fits around mounting bolt (A).

### Removing the Swingaway Padded Armrest

1. Remove swing away padded armrest (D) from armrest socket (E).

### Adjusting Height of the Swingaway Padded Armrest

1. Remove the swing away padded armrest (D) from the armrest socket (E).
2. Remove the mounting bolt (A) and locknut (B) mounted in the armrest socket.
3. Reposition mounting bolt (A) to one of three positions (C) in the armrest socket depending on the desired height.
4. Install locknut (B) and securely tighten.
5. Reinstall the swing away padded armrest (D) into the armrest socket (E).
6. Repeat STEPS 1-5 for the opposite side, if necessary.

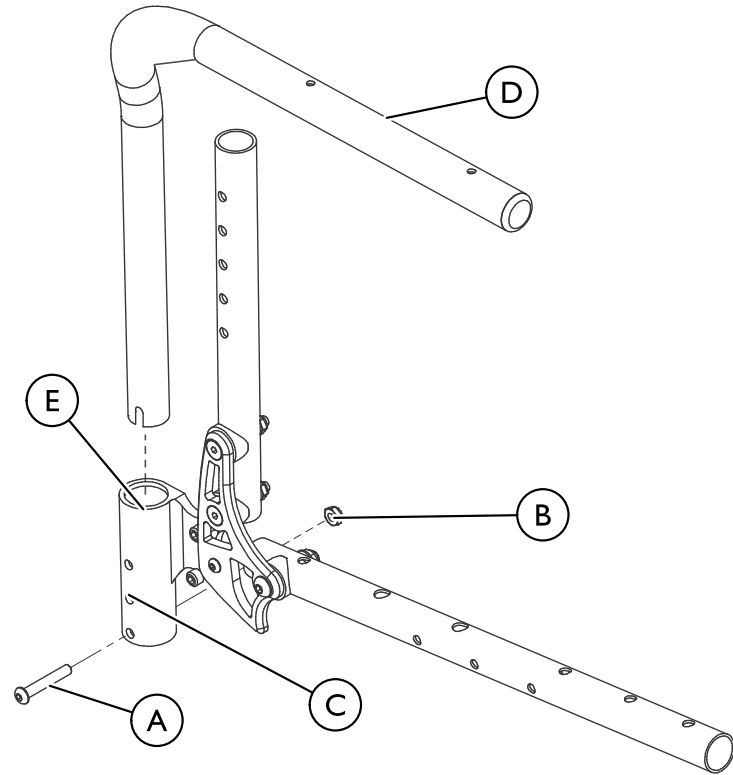

### 5.3 Removing/Installing Foldover Back Upholstery



#### WARNING!

– ALWAYS perform these procedures in the presence of an assistant. The position of the footrest, camber tube, seat angle, back angle, the tautness of the back upholstery as well as the user's condition are directly related to the wheelchairs stability. Any change to one or any combination of the five may cause the wheelchair to decrease in stability. Use **EXTREME** caution when using a new seating position. The addition of anti-tippers may be required.

#### Removing Foldover Back Upholstery

1. Unfasten the two fastening flaps (A) that secure the bottom of the existing back upholstery (B) to the back canes (C).
2. Unfold the top of the back upholstery (B).
3. Lift up on the existing back upholstery (B) and remove from the wheelchair.

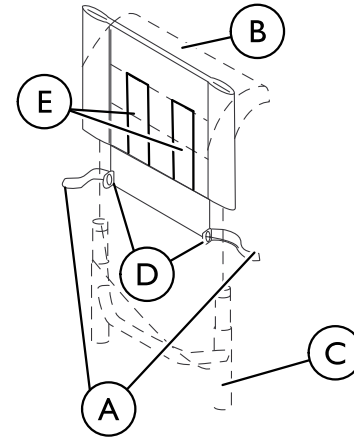

#### Installing Foldover Back Upholstery

1. Install the new back upholstery (B) onto the back canes (C).
2. Wrap the end of a fastening flap (A) around the back cane (C).
3. Insert the end of the fastening flap (A) through the loop (D).
4. Wrap the fastening flap (A) around the back cane (C) again and press firmly to secure.
5. Fold the top of the back upholstery (B) down over the back canes (C) towards the front of the wheelchair.
6. Press firmly to secure the fastening strips (E).

## 5.4 Removing/Installing the Back Frame

### Removing

1. Fold the back down. Refer to 4.3 Unfolding/Folding the Back, page 31.
2. Loosen rear seat upholstery screw, plastic washer, covered spacer, (A) and two short mounting screws, (B) but DO NOT remove.
3. Remove the spring pin assembly (C) that secures the back angle plates (D) to the seat rails (E).
4. Remove the back assembly (F) from the wheelchair.

### Installing

1. Insert backframe (F) into lock down folding back latches (G) using two short mounting screws (B).
2. Install the spring pin assembly (C) through the back angle plate (D) and seat rail (E).
3. Install the rear seat upholstery screw, plastic washer, and covered spacer (A) through the back angle plate (D) to the seat rail (E).
4. Perform STEPS 1- 3 for remaining back angle plate (D).
5. Tighten spring pin assembly (C) enough to secure the backframe (F) to the seat rail (E), while allowing the back (F) to fold properly.
6. Securely tighten the locknut on the rear seat upholstery screw (A) while holding the rear seat upholstery screw (A) from rotating.
7. Repeat STEPS 17 - 18 for remaining back angle plate (D).
8. Unfold back to upright position. Refer to 4.3 Unfolding/Folding the Back, page 31.

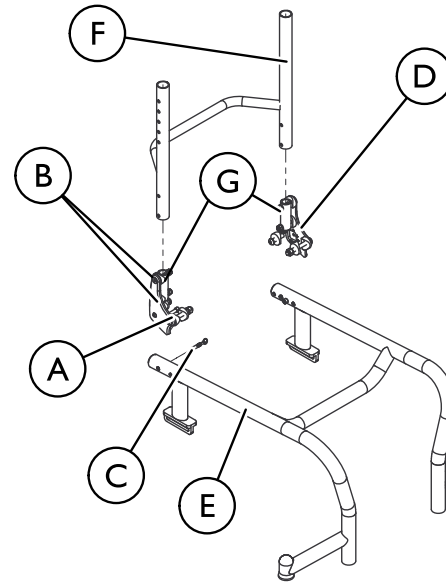

 Back shown in upright position and seat upholstery not shown for clarity of hardware location.

## 5.5 Replacing Adjustable Tension Seat Upholstery



### WARNING!

- The seat upholstery and/or cushion **MUST** be cleaned regularly and/or replaced if incontinence is frequent. The risk of pressure sores is significantly higher with seat upholstery that is wet and/or soiled.

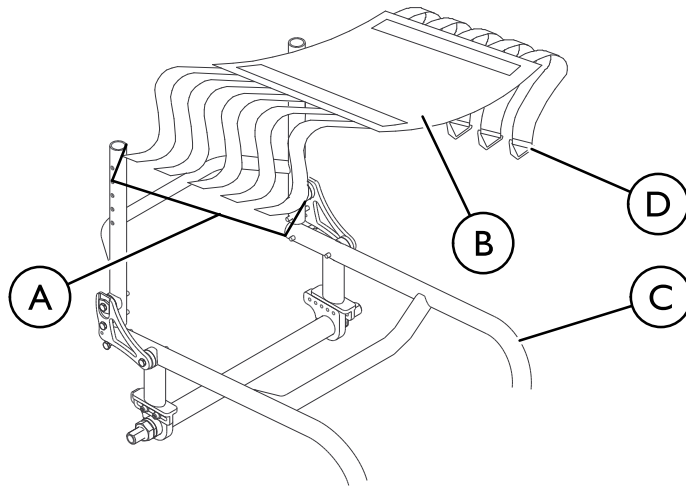

1. Remove the seat cushion and back upholstery from the wheelchair.
2. Place the wheelchair onto its two rear wheels and back canes.
3. Unlatch the five adjusting straps (A) that secure the seat upholstery (B) to the wheelchair frame (C).
4. Remove the existing seat upholstery (B).
5. Place the wheelchair back onto all four wheels.



Right and left is determined by sitting in the wheelchair.



The seat upholstery (B) **MUST** be positioned with the three rear adjusting straps (A) towards the rear of the top crossbar (C) for proper installation.

6. Position new seat upholstery (B) onto the wheelchair frame (C), ensuring the five adjusting straps (A) hang over the right and left sides of the wheelchair.
7. Pull the front adjuster straps (A) around and under the wheelchair frame top bars (C).
8. Slip front adjuster strap (A) through corresponding anchor loop (D) and adjust the seat upholstery (A) to desired tension. Secure the adjustment straps.
9. Place the wheelchair onto its two rear wheels and back cane.
10. Securely latch the four remaining adjuster straps (A) together.
11. Return wheelchair to upright position.
12. Reinstall the seat cushion and back upholstery.

## 5.6 Replacing Screw-On Seat Upholstery Option



### WARNING!

- ALWAYS perform these procedures in the presence of an assistant. The position of the footrest, camber tube, seat angle, back angle, the tautness of the back upholstery as well as the user's condition are directly related to the wheelchairs stability. Any change to one or any combination of the five may cause the wheelchair to decrease in stability. Use **EXTREME** caution when using a new seating position. The addition of anti-tippers may be required.
- After ANY adjustments, repair or service and BEFORE use, make sure all attaching hardware is tightened securely - otherwise injury or damage may occur.

WHEELCHAIR DEPTH	NUMBER OF SCREWS
14 to 15 inches	10
16 to 17 inches	12
18 inches	14
19 to 20 inches	16

1. Remove the seat cushion from the wheelchair.
2. Remove the mounting screws that secure the seat upholstery (A) to the seat frame.
3. Lift up on the back upholstery cover separating the fastening strips of the back upholstery cover (B) from the fastening strips of the seat (Detail “A”).
4. Remove the existing seat upholstery (A).

5. Install new seat upholstery (A) and secure in place with mounting screws. Tighten securely.
6. Install the seat cushion onto the wheelchair.

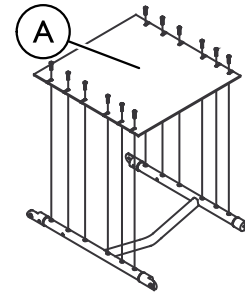
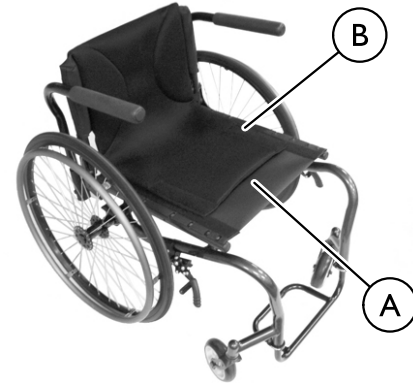

**DETAIL “A”**



## 5.7 Removing/Installing Rear Wheels



### WARNING!

– After any adjustments, repair or service and before use, make sure all attaching hardware is tightened securely - otherwise injury or damage may occur.



### CAUTION!

– Changing the size of the rear wheels can affect the performance of the wheelchair. Contact Invacare at the telephone numbers on the back of this manual before changing rear wheel size.

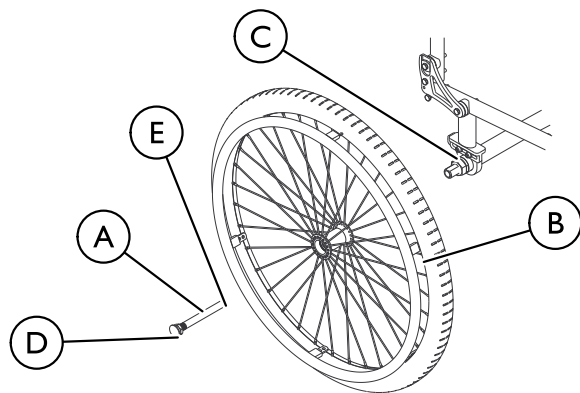

Quad-Release Axle not shown. Locking pins on the Quad-Release Axle are the same as Quick-Release Axle.

I. Perform one of the following:

- Quick-Release - Push in the tip of the quick-release axle (A) and pull axle (A) and wheel (B) away from the wheelchair (C).
  - Quad-Release - Lift up on the handle of the quad-release axle and pull axle and wheel (B) away from the wheelchair (C).
2. Repeat STEP 1 for the opposite rear wheel (B).
  3. Reinstall the rear wheels (B) onto the wheelchair (C) by reversing STEPS 1-2.



### WARNING!

– Pull on the rear wheel (B) to make sure the detent pin (D) and locking pins (E) of the quick/quad-release axle are fully released before operating wheelchair.  
– Keep locking pins (E) clean.

4. If there is too much movement of the rear wheel assembly in an “in and out” motion, refer to 4.7 Adjusting Quick-Release Axles, page 43 or 4.8 Adjusting Quad-Release Handles, page 43.

## 5.8 Replacing Quad-Release Axles

 End of Quick Release axle **A** is shown for reference only. It is not visible when inserted into camber bar.

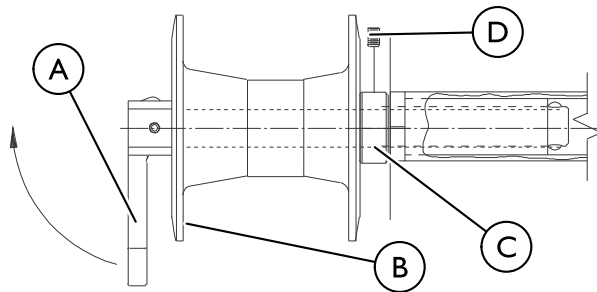

1. Remove rear wheel and the existing quick-release axle **A** from the wheelchair. Refer to 5.7 Removing/Installing Rear Wheels, page 65.
2. Remove existing quick-release axle **A** from rear wheel.
3. Insert new quad-release axle through rear wheel hub **B**.
4. Slide locking collar **C** onto quad-release axle until it is snug against rear wheel and tighten securely with allen screw **D**.
5. Reinstall rear wheel and the quad-release axle onto the wheelchair. Refer to 5.7 Removing/Installing Rear Wheels, page 65.
6. Flip the handle of the quad-release axle down to release the detent pin ensuring that the locking pins are fully released.
7. If detent pin does not fully release, proceed to 4.8 Adjusting Quad-Release Handles, page 43.
8. Repeat STEPS 1–7 for the opposite rear wheel.

## 5.9 Handrim Replacement

1.

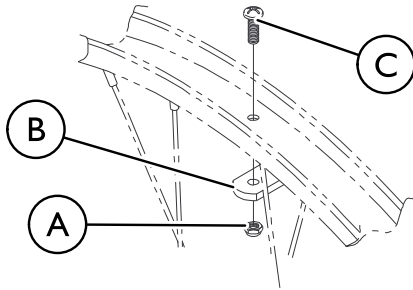

2. Remove the rear wheel from the wheelchair. Refer to 5.7 Removing/Installing Rear Wheels, page 65.



### WARNING!

– Tire **MUST** be fully deflated before any disassembly procedures are performed. Otherwise injury or damage may result.

3. Remove all air from the tube by pressing down on the pin in the center of the valve stem.
4. While carefully holding the tire, tube and rim strip to one side, hold the allen screws © and remove the locknuts (A) that secure the handrim to the rear wheel (B).
5. Remove the existing handrim.
6. Install new handrim by reversing STEPS 2-4.



### WARNING!

– **DO NOT** inflate tire until it is completely assembled. Otherwise injury or damage may result.

7. Inflate tire to correct psi rating on the sidewall of tire.
8. Reinstall rear wheel to the wheelchair. Refer to 5.7 Removing/Installing Rear Wheels, page 65.
9. Repeat STEPS 1-7 for opposite rear wheel if necessary.

## 5.10 Repairing/Replacing Rear Wheel, Tire/Tube



### **WARNING!**

- Replacement of the tire or tube **MUST** be performed by a qualified technician.



### **CAUTION!**

- Changing the size of the rear wheels can affect the performance of the wheelchair. Contact Invacare at the numbers on the back cover **BEFORE** performing this procedure.



If replacing rear wheels with a different size than what was originally on the wheelchair, the front caster height and/or diameter **MUST** also be changed to keep the wheelchair frame parallel to the floor. Refer to 5.12 Removing/Installing/Repositioning the Caster Assemblies, page 70 **ONLY** after contacting Invacare. Anti-tipper height (if applicable) **MUST** also be adjusted to maintain 1-1/2 to 2-inch clearance between bottom of the anti-tipper wheels and the floor. Refer to 4.19 Adjusting/Replacing Anti-tipper, page 55

## 5.1.1 Removing/Installing the Camber Tube



### CAUTION!

- Camber tube clamps **A** - Make sure the clamp screws **B** are securely tightened before using the wheelchair, otherwise personal injury or damage to the wheelchair may occur.

### Removing the Camber Tube

1. Remove the rear wheels. Refer to 5.7 Removing/Installing Rear Wheels, page 65.
2. Loosen the two socket head clamp screws **B** securing camber tube **C** to the two camber tube clamps **A**.
3. Slide the camber tube **C** through the camber tube clamps **A**.

### Installing the Camber Tube

1. Insert the camber tube **C** into the camber tube clamps **A**.
2. Center the camber tube **C** in the camber tube clamps **A**.
3. Adjust the camber tube **C**. Refer to 4.14 Adjusting the Camber Tube, page 50 .



There are four types of camber tubes **C**: 0° **D**, 3° **E**, 6° **F** and 9° **G**. If the camber tube **C** being used is 3° **E**, 6° **F** or 9° **G** degrees, then the camber tube **C** MUST be rotated so that the axle bushings **H** at the ends of camber tube **C** are angled up (Detail "A"). Installing the camber tube **C** in any other orientation will directly impact the angle of the rear wheel.

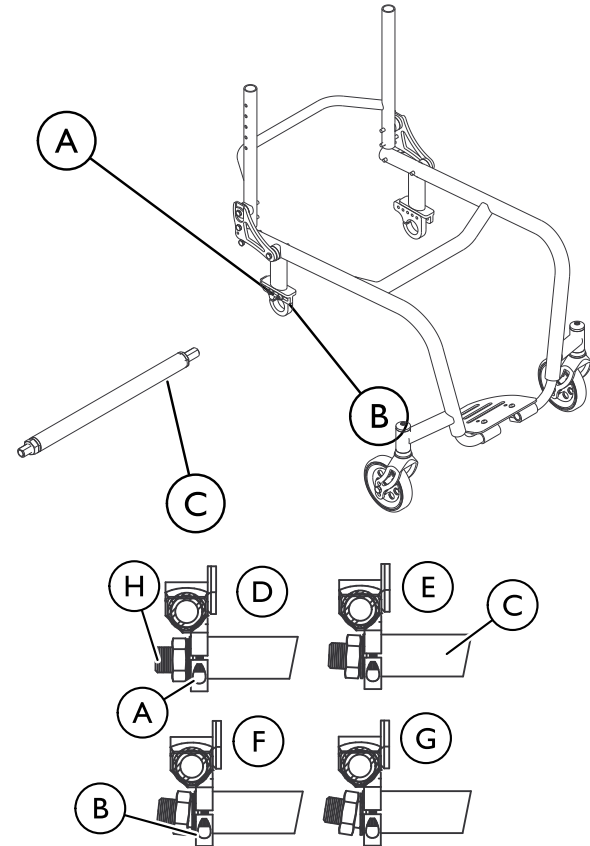

**DETAIL "A" — CORRECT ORIENTATION FOR EACH CAMBER TUBE**

## 5.12 Removing/Installing/Repositioning the Caster Assemblies

 If replacing a front caster note the mounting position of the existing front caster for installation of the new front caster.

Both front casters **MUST** be the same size and adjusted to the same height.

### Standard Forks

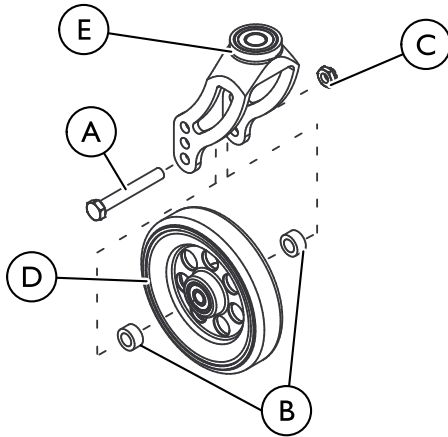

### Removing Front Caster

1. Remove the mounting bolt (A), axle spacers (B) and locknut (C) that secure the front caster (D) to the fork (E).
2. Remove the caster (D) from the fork (E).

### Installing Front Caster

1. Using the mounting bolt (A), axle spacers (B) and locknut (C), secure the caster (D) to the desired caster (E) mounting position.

### Suspension Forks

### Removing the Caster

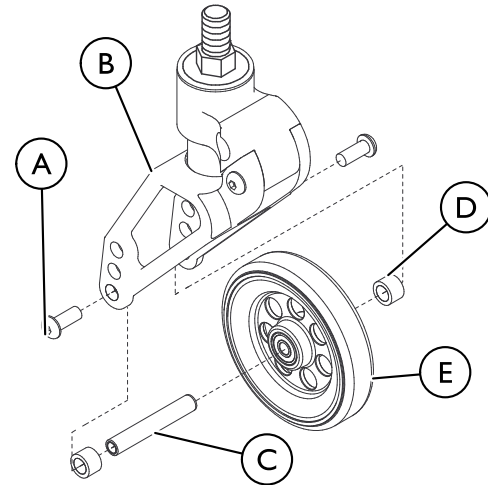

 One mounting screw will not turn.

1. Using two allen wrenches, turn mounting screws (A) in opposite directions and remove one mounting screw from fork (B).
2. Remove the threaded bushing (C) with mounting screw (A) and two spacers (D) securing the caster (E) to the fork (B). DO NOT use excessive force.
3. Remove the caster (E) from the fork (B).

### Installing the Caster

1. Align the caster (E) with the desired mounting holes in the fork (B).
2. Insert the threaded bushing (C) with mounting screw (A), through the two axle spacers (D) and caster (E). DO NOT use excessive force.



#### WARNING!

– Use Loctite™ 242 when reinstalling the mounting screw (A) into the threaded bushing (C). Otherwise the fork (B) can become disassembled. Possible injury or damage could result.

3. Apply Loctite 242 to the mounting screw (A).
4. Reinstall the mounting screw (A) into the threaded bushing (C) and tighten securely.

### One Sided Fork

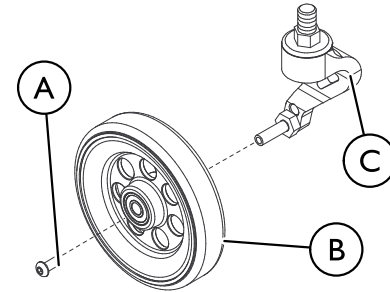

### Removing the Caster

1. Remove the button head screw (A) that secures the caster (B) to the fork (C).

### Installing the Caster

1. Secure caster (B) to one sided fork (C) with button head screw (A). Tighten securely.

## 5.13 Removing/Installing the Fork Assembly



- If replacing a fork, note the mounting position of the existing front caster for installation of the new fork.

### Removing Fork Assembly

1. Remove the front caster from the fork. Refer to 5.12 Removing/Installing/Repositioning the Caster Assemblies, page 70.
2. Perform one of the following:
  - Standards Forks — Remove locknut (A) securing the fork (B) from the fork stem (C) (Detail “A”).
  - Suspension Fork (Detail “B”)
    - a. Unscrew fork stem (C) from head tube (D).
  - One Sided Fork (Detail “C”)
    - a. Unscrew fork stem (C) from head tube (D).

### Installing Fork Assembly



#### **WARNING!**

- Use Loctite™ 242 on threads on fork stem (C) when reinstalling the suspension fork or one sided fork into the head tube (D). Otherwise, the fork (B) may become loose and disengage from the head tube (D). Possible injury or damage could result.

1. Perform one of the following:

#### **DETAIL “A” — STANDARD FORK**

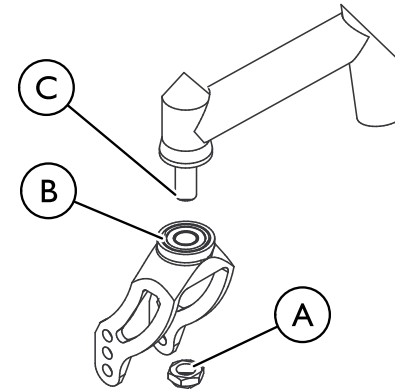

- Standard Forks - Using a locknut (A), secure the fork (B) to the fork stem (C) (Detail “A”).

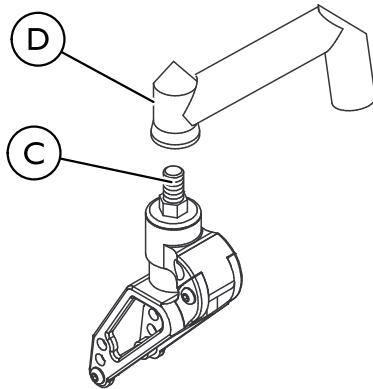

**DETAIL “B” — SUSPENSION FORK**

- Suspension Fork (Detail “B”) -
  - a. Apply Loctite 242 on stem threads.
  - b. Screw fork stem © into head tube ©. Tighten securely.

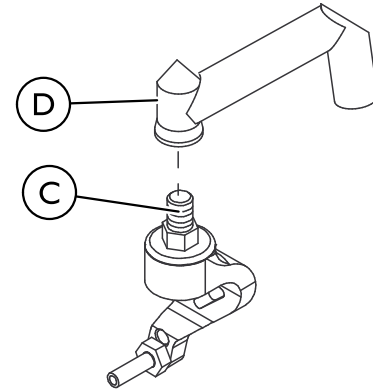
**DETAIL “C” — ONE SIDED FORK**

- One Sided Fork (Detail “C”)
    - a. Apply Loctite 242 on stem threads.
    - b. Screw fork stem © into head tube ©. Tighten securely.
2. Install the front caster. Refer to 5.12 Removing/Installing/Repositioning the Caster Assemblies, page 70.

## 5.14 Removing/Installing the Elastomers (Suspension Forks Only)



### CAUTION!

– DO NOT use excessive force when removing/installing the threaded sleeve from/onto the fork. Damage to the threaded sleeve may occur.

### Removing the Elastomer



One mounting screw will not turn.

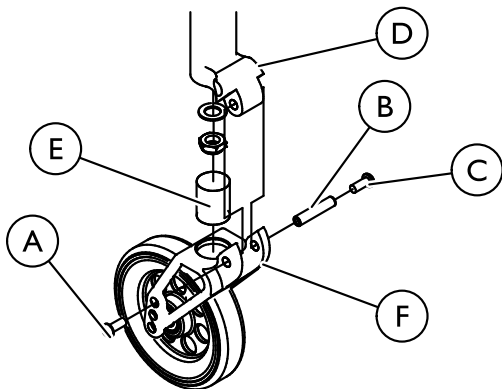

1. Using two allen wrenches, turn mounting screws **A** in opposite directions and remove one mounting screw **A** from fork .
2. Remove the threaded bushing **B** and mounting screw **C** securing the suspension fork top **D** to the elastomer **E** and the suspension fork bottom **F**. DO NOT use excessive force.
3. If replacing the elastomer **E**, discard the existing elastomer **E**.

### Installing the Elastomer

1. Position the new elastomer **E** between the suspension fork top **D** and suspension fork bottom **F**.
2. Align the mounting holes in the suspension fork top **D** and suspension fork bottom **F**.
3. Using the threaded bushing **B** and mounting screw **C**, secure the suspension fork top **D** and suspension fork bottom **F**. DO NOT use excessive force.



### WARNING!

– Use Loctite 242 when reinstalling the mounting screw **C** into the threaded bushing **B**. Otherwise the fork can become disassembled. Possible injury or damage could result.

4. Apply Loctite 242 to the mounting screw **C**.
5. Reinstall the mounting screw **C** into the threaded bushing **B** and tighten securely.

## 5.15 Replacing/Adjusting the Wheel Locks



### WARNING!

– After any adjustments, repair or service and before use, make sure all attaching hardware is tightened securely - otherwise injury or damage may occur.



### WARNING!

– If wheel locks DO NOT hold the occupied wheelchair in place contact a qualified technician - otherwise injury or damage may occur.



Before adjusting or replacing wheel locks, ensure that the tires are inflated to the recommended psi on the sidewall of the tire.

### Replacing the Wheel Lock

1. Loosen the two mounting screws and remove the existing wheel lock from the wheelchair.
2. Using the two mounting screws, install the new wheel lock. Securely tighten.

### Adjusting the Wheel Lock

1. Engage the wheel locks **A**.
  - i** Any wheel lock adjustment should embed the wheel lock shoe **D** at least 3/16-inch (0.48cm) **C** into the pneumatic tire **E** (1/8-inch (0.32cm) for urethane wheels) when engaged.
2. If necessary, loosen the two mounting screws **B** that secure the wheel locks **A** to the wheelchair frame and adjust position of the wheel lock **A** until the 3/16-inch (1/8-inch for urethane wheels) measurement **C** is obtained for correct wheel lock adjustment.
3. Securely tighten the two mounting screw(s) **B**.

4. Engage the wheel locks **A** and push against the wheelchair and determine if the wheel locks **A** engage the tires **E** enough to hold the wheelchair.
5. Repeat the above procedures until the wheel locks **A** hold the wheelchair.

#### Push-to-Lock or Pull-to-Lock Wheel Locks

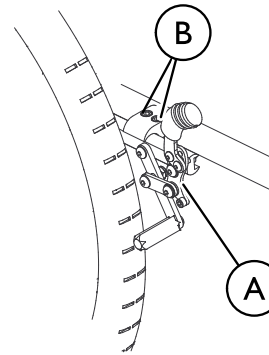

#### Under Mount Wheel Lock

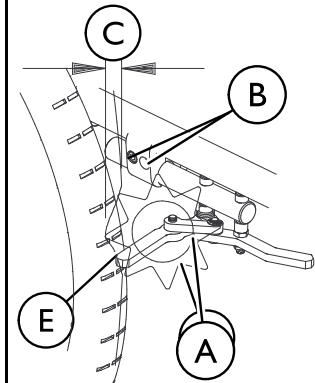

## 6 Maintenance

### 6.1 Maintenance



#### CAUTION!

- DO NOT overtighten hardware attaching to the frame. This could cause damage to the frame tubing.

#### Suggested Maintenance Procedures

1. Before using your wheelchair, make sure all nuts and bolts are tight.
2. Check all parts for damage or wear and replace.
3. Check all parts for proper adjustment.



#### WARNING!

- DO NOT use your wheelchair unless it has the proper tire pressure (p.s.i.).
- DO NOT overinflate the tires. Failure to follow these suggestions may cause the tire to explode and cause bodily harm. The recommended tire pressure is on the sidewall of the tire.



#### CAUTION!

- As with any vehicle, the wheels and tires should be checked periodically for cracks and wear, and should be replaced if damaged. Replace as recommended, refer to 5.15 Replacing/Adjusting the Wheel Locks, page 75 and 5.10 Repairing/Replacing Rear Wheel, Tire/Tube, page 68.

4. The rear wheels, casters and tires should be checked periodically for cacks and wear, and should be replaced by a qualified technician if damaged.

5. Periodically adjust wheel locks in correlation to tire wear. Refer to 5.15 Replacing/Adjusting the Wheel Locks, page 75.



Tire wear is excessive if:

Pneumatic Tires - there is missing tread or the tires are bald.

Urethane Tires - there are cuts, surface defects or the tires are loose on the rims.

Rubber Tires - 30% or more of the tire has worn away.

**Invacare recommends that rear wheel tire/tube and caster tire/tube be replaced every five years.**

6. Periodically check handrims to ensure they are secured to the rear wheels. Refer to 5.9 Handrim Replacement, page 67.
7. Periodically check caster wheel bearings to make sure they are clean and free from moisture. Use a Teflon® lubricant if necessary.
8. Check upholstery for sagging, rips or tears.
9. Clean upholstery with mild soap and water.
10. Hand grips should be checked monthly for wear/looseness/deterioration. Clean if desired. Replace if looseness or deterioration is found.
11. Replace any labels that are missing, worn or torn.

#### Replacing/Repairing Rear Wheel Tire/Tube



#### WARNING!

- Replacement of solid urethane tires is not recommended. If the solid urethane tire needs repaired, Invacare recommends replacing the complete wheel assembly.
- Replacement of rear wheel tube must be performed by a qualified technician.

## Replacing/Repairing Caster Tire/Tube



### **WARNING!**

- Replacement of solid urethane or semi-pneumatic tires is not recommended. If the solid urethane or semi-pneumatic tires need replaced, Invacare recommends replacing complete caster assembly.
- For pneumatic tires, replacement of the tube must be performed by a qualified technician.

## 7 Troubleshooting

### 7.1 Troubleshooting

CHAIR VEERS RIGHT	CHAIR VEERS LEFT	SLUGGISH TURN OR PERFORMANCE	CASTER FLUTTERS	SQUEAKS AND RATTLES	LOOSENESS IN CHAIR	SOLUTIONS
X	X	X	X			Check tires for correct and equal pressure.
		X	X	X	X	Check for loose stem nuts.
				X	X	Check spokes and nipples.
X	X		X			Check that both casters contact the ground at the same time.
X	X	X				Check toe in/toe out.

## 8 Options

### 8.1 Options

#### Installing/Adjusting the Fold-in Sideguards

##### Installing

1. Place the clamp (A) around the wheelchair frame (B).
2. Inset the bolt through the clamp (A) and tighten to attach the clamp (A) to the wheelchair frame (B).
3. Place the sideguard clamp (D) around the back post (E) by sliding the sideguard clamp (D) onto the back post (E).
4. Insert the bolt through the sideguard clamp (D) and sideguard (C) and tighten securely.

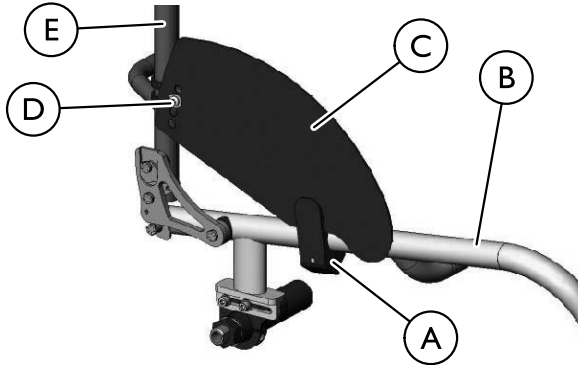

**i** If sideguard will not pivot freely, bolt through sideguard clamp (D) and sideguard (C) is too tight. To correct, loosen bolt.

If sideguard rattles, bolt through sideguard clamp (D) and sideguard (C) is too loose. To correct, tighten bolt.

Fold-in sideguard should be able to be moved vertically (Detail "A") and horizontally (Detail "B").

##### DETAIL "A"

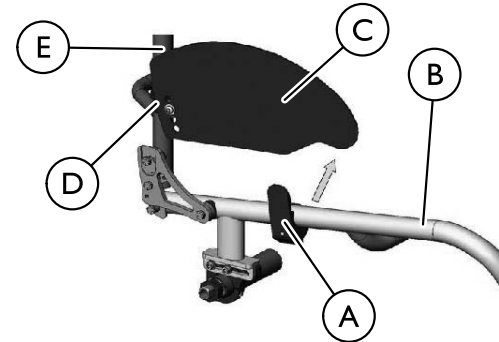

### DETAIL "B"

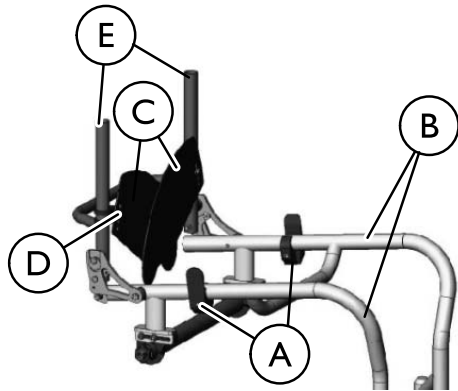

### Adjusting the Fold-In Sideguards Height

1. Lift sideguard to a level position (Detail "A").
2. Remove bolt from sideguard clamp D and sideguard C.
3. Adjust sideguard C to desired height.
4. Insert bolt through sideguard clamp D and sideguard C.
5. Tighten securely.
6. Repeat for opposite side.

### Installing/Removing the Removable Side Guards

#### Installing

1. Loosen two mounting screws A in side guard B.
2. Attach side guard clamp C to the back posts.
3. Tighten two mounting screws A securely.

#### Removing

1. Loosen two mounting screws A in side guard B.
2. Remove side guard clamp C from back posts.

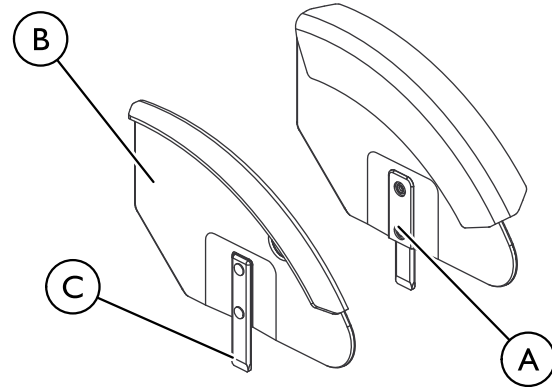



## Installing the Bolt-on Push Handles

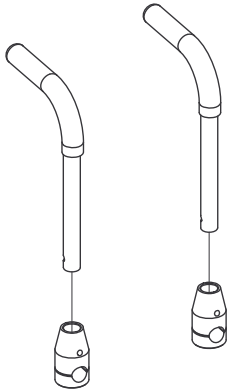

Using the mounting screw attach the bolt-on push handles to the back canes.

## Installing/Adjusting the Adjustable Push Handles

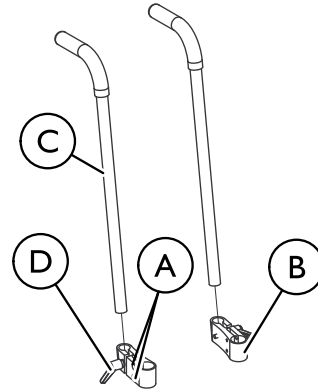

### **WARNING!**

- Push handles must be securely fastened. Otherwise injury may occur.
- If possible, insert bolt through integral push handles.

### To Install:

1. Loosen the two mounting screws **A** in the push handle clamp **B**.
2. Attach adjustable push handle **C** to back cane by inserting the front of the wheelchair frame into the push handle clamp **B**.
3. Tighten the two mounting screws **A** in the push handle clamp **B**.
4. Insert the adjustable push handle **C** into the push handle clamp **B**.
5. Repeat for opposite side.

To Adjust:

1. Insert adjustable push handle ③ into the push handle clamp ②.
2. Adjust to desired height.
3. Flip lever ④ to secure adjustable push handle ③.
4. Repeat for opposite side.

**Additional Options**

**Crutch Holder**

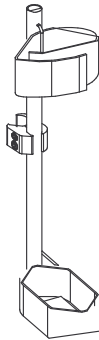

Attaches to backframe with clamp.

**Luggage Carrier**

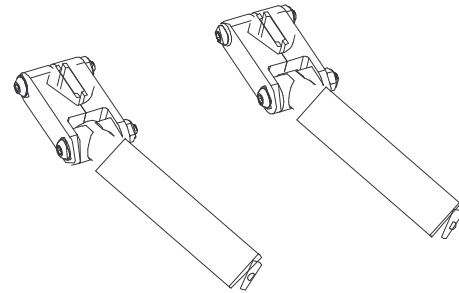

Attach luggage bracket to front frame with mounting screws.

**Backpack**

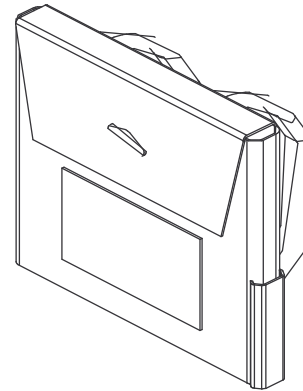

Attach backpack to the backframe using backpack straps.

## Seat Pouch

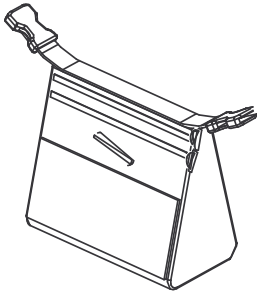

## Frame Protectors

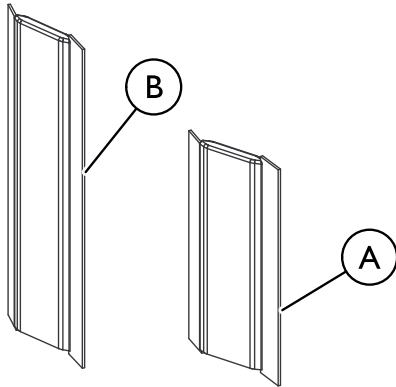

The rear frame protector <sup>Ⓐ</sup>

The front frame protector <sup>Ⓑ</sup>

## Seat Positioning Strap

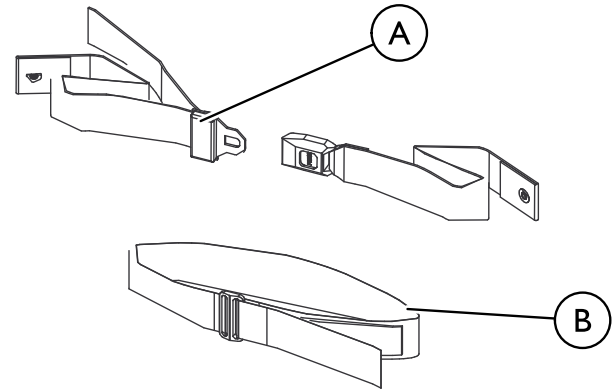

Buckle style strap <sup>Ⓐ</sup> bolts on to the chair.

Hook and loop style strap <sup>Ⓑ</sup> wraps around the back frame and fastens in front.

## Leg Strap

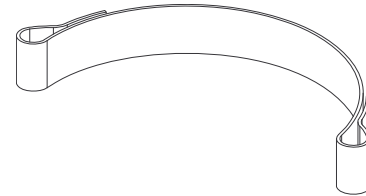

Secure legs around the calves with the leg strap.

---

## 9 Warranty

---

### 9.1 Warranty Information

#### United State Limited Warranty

**PLEASE NOTE: THE WARRANTY BELOW HAS BEEN DRAFTED TO COMPLY WITH FEDERAL LAW APPLICABLE TO PRODUCTS MANUFACTURED AFTER JULY 4, 1975.**

This warranty is extended only to the original purchaser who purchases this product when new and unused from Invacare or a dealer. This warranty is not extended to any other person or entity and is not transferable or assignable to any subsequent purchaser or owner. Coverage under this warranty will end upon any such subsequent sale or other transfer of title to any other person.

This warranty gives you specific legal rights and you may also have other legal rights which vary from state to state.

Invacare warrants the frames when purchased new and unused to be free from defects in materials and workmanship for a period of three (3) years from the date of purchase for the Crossfire All-Terrain and a period of five (5) years from the date of purchase for the Crossfire Titanium and Crossfire T6 from Invacare or a dealer, with a copy of the seller's invoice required for coverage under this warranty.

Invacare warrants the upholstered materials (seat and back) and remaining components of this product when purchased new and unused to be free from defects in materials and workmanship for a period of thirty-six (36) months from date of purchase from Invacare or a dealer, with a copy of the seller's invoice required for coverage under this warranty. If within such warranty periods any such product shall be proven to be defective, such product shall be repaired or replaced, at Invacare's option. This warranty does not include any labor or shipping charges incurred in replacement part installation or repair of any such product. Invacare's sole obligation and your exclusive remedy under this warranty shall be limited to such repair and/or replacement.

For warranty service, please contact the dealer from whom you purchased your Invacare product. In the event you do not receive satisfactory warranty service, please write directly to Invacare at the address at the bottom of this page. Provide dealer's name, address, the product model number, date of purchase, indicate nature of the defect and, if the product is serialized, indicate the serial number. Do not return products to our factory without our prior consent.

**LIMITATIONS AND EXCLUSIONS: THE FOREGOING WARRANTY SHALL NOT APPLY TO SERIAL NUMBERED PRODUCTS IF THE SERIAL NUMBER HAS BEEN REMOVED OR DEFACED, PRODUCTS SUBJECTED TO NEGLIGENCE, ACCIDENT, IMPROPER OPERATION, MAINTENANCE OR STORAGE, PRODUCTS MODIFIED WITHOUT INVACARE'S EXPRESS WRITTEN CONSENT INCLUDING, BUT NOT LIMITED TO, MODIFICATION THROUGH THE USE OF UNAUTHORIZED PARTS OR ATTACHMENTS; PRODUCTS DAMAGE BY REASON OF REPAIRS MADE TO ANY COMPONENT WITHOUT THE SPECIFIC CONSENT OF INVACARE, OR TO A PRODUCT DAMAGED BY CIRCUMSTANCES BEYOND INVACARE'S CONTROL, AND SUCH EVALUATION WILL BE SOLELY DETERMINED BY INVACARE. THE WARRANTY SHALL NOT APPLY TO NORMAL WEAR AND TEAR OR FAILURE TO ADHERE TO THE PRODUCT INSTRUCTIONS.**

**THE FOREGOING EXPRESS WARRANTY IS EXCLUSIVE AND IN LIEU OF ANY OTHER WARRANTIES WHATSOEVER, WHETHER EXPRESS OR IMPLIED, INCLUDING THE IMPLIED WARRANTIES OF MERCHANTABILITY AND FITNESS FOR A PARTICULAR PURPOSE, AND THE SOLE REMEDY FOR VIOLATIONS OF ANY WARRANTY WHATSOEVER, SHALL BE LIMITED TO REPAIR OR REPLACEMENT OF THE DEFECTIVE PRODUCT PURSUANT TO THE TERMS CONTAINED HEREIN. THE APPLICATION OF ANY IMPLIED WARRANTY WHATSOEVER SHALL NOT EXTEND BEYOND THE DURATION OF THE EXPRESS WARRANTY PROVIDED HEREIN. INVACARE SHALL NOT BE LIABLE FOR ANY CONSEQUENTIAL OR INCIDENTAL DAMAGES WHATSOEVER.**

**SOME STATES DO NOT ALLOW THE EXCLUSION OR LIMITATION OF INCIDENTAL OR CONSEQUENTIAL DAMAGE, OR LIMITATION OF HOW LONG AN IMPLIED WARRANTY LASTS, SO THE ABOVE EXCLUSION AND LIMITATION MAY NOT BE APPLICABLE.**

**THIS WARRANTY SHALL BE EXTENDED TO COMPLY WITH STATE/PROVINCIAL LAWS AND REQUIREMENTS.**

## 9.2 Usability Survey

Please complete the survey below to evaluate this manual.  
Your participation in the evaluation assists in the development of effective and usable manuals for our customers.

The survey is also available online:  
<http://www.invacare.com/TechnicalDocumentSurvey>



**Yes, you can!**

1. Please indicate your primary involvement with the product (choose one):

- |   |  |
|---|--|
| <input type="checkbox"/> Product User/Owner | <input type="checkbox"/> Product Service Technician    |
| <input type="checkbox"/> User Assistant     | <input type="checkbox"/> Health Care Provider          |
| <input type="checkbox"/> Product Dealer     | <input type="checkbox"/> Other (please specify): _____ |

2. Please indicate which product manual you are evaluating:  
\_\_\_\_\_

3. Evaluate the content:

	YES	NO
After reading this document, do you have a better understanding of how to use the product?	<input type="checkbox"/>	<input type="checkbox"/>
Do you have a better understanding of any limitations on the use of this product?	<input type="checkbox"/>	<input type="checkbox"/>
Is there any irrelevant information?	<input type="checkbox"/>	<input type="checkbox"/>
Is the Table of Contents useful?	<input type="checkbox"/>	<input type="checkbox"/>
Does any information seem inaccurate/misleading?	<input type="checkbox"/>	<input type="checkbox"/>
Do you understand that misuse of the product can cause injury or damage?	<input type="checkbox"/>	<input type="checkbox"/>
Explain: _____		

4. Evaluate the Warnings/Cautions:

	YES	NO
Are there any warnings/cautions that you do not understand?	<input type="checkbox"/>	<input type="checkbox"/>
Are there too many warnings/cautions?	<input type="checkbox"/>	<input type="checkbox"/>
Are there warnings/cautions that you feel do not apply to this product?	<input type="checkbox"/>	<input type="checkbox"/>

Explain:  
\_\_\_\_\_

5. Evaluate the style:

	YES	NO
Is anything hard to locate/follow?	<input type="checkbox"/>	<input type="checkbox"/>
Are any headings missing/confusing?	<input type="checkbox"/>	<input type="checkbox"/>
Are there too many headings?	<input type="checkbox"/>	<input type="checkbox"/>
Should any material be a bulleted list or checklist instead of numbered steps or a paragraph?	<input type="checkbox"/>	<input type="checkbox"/>
Is there material that might be clarified by a visual?	<input type="checkbox"/>	<input type="checkbox"/>

Explain:  
\_\_\_\_\_

6. Evaluate the illustrations:

	YES	NO
Are the illustrations useful?	<input type="checkbox"/>	<input type="checkbox"/>
Do the illustrations need more or less detail?	<input type="checkbox"/>	<input type="checkbox"/>
Is the number/size of illustrations adequate?	<input type="checkbox"/>	<input type="checkbox"/>

Explain:  
\_\_\_\_\_

7. Do you have suggestions for other ways of making this document easier to use?

Explain:	YES	NO
_____	<input type="checkbox"/>	<input type="checkbox"/>
_____		

**Thank You!** Thank you for completing this survey. If you have any questions or we may be of assistance to you, please feel free to contact us.

Send your survey to Invacare Technical Writing Department: [TechnicalWriting@invacare.com](mailto:TechnicalWriting@invacare.com)  
or Invacare Corporation: One Invacare Way, Elyria, Ohio 44035 FAX: 440-329-6975

Notes

**Invacare Corporation**

**USA**

One Invacare Way

Elyria, Ohio USA

44036-2125

(800) 333-6900

[www.invacare.com](http://www.invacare.com) and [www.topendchair.com](http://www.topendchair.com)

Manufactured by:

Top End Sports and Recreation Products

4501 63rd Circle North

Pinellas Park, Florida

(727) 522-8677

(800) 532-8677



1134872-D-08 2013-09-25



**Making Life's Experiences Possible™**



**Yes, you can.®**