

**Garaventa STAIR-TRAC SA-2**

# **Owner's Manual**

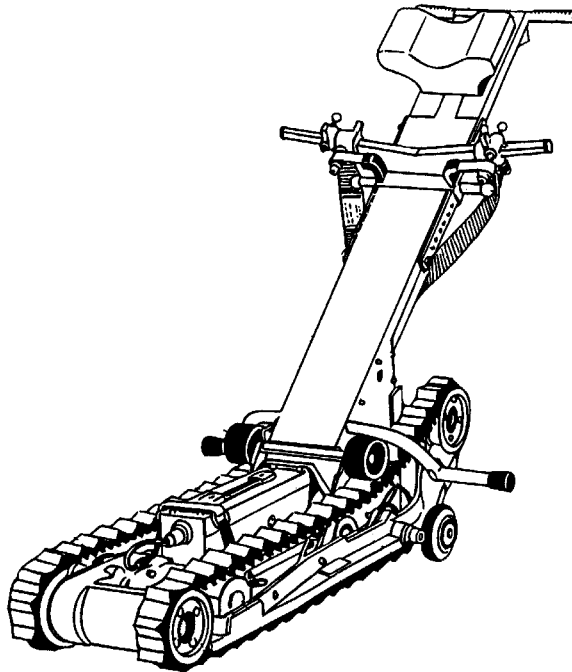

---

---

## Table of Contents

1. Safety First .....	2
2. Terminology .....	4
3. Operating Instructions .....	5
Introduction .....	5
Stair Slope Indicator .....	5
Attaching Wheelchair Support Handle .....	5
Attaching Wheelchairs .....	6
Detaching Wheelchairs .....	8
Horizontal Travel .....	9
Emergency Stop Button .....	9
Ascending Stairs .....	9
Descending Stairs .....	11
Storage .....	12
4. Operating Tips .....	13
5. Optional Equipment .....	15
Wheelchair Attachment Ramp .....	15
Vehicle Loading Ramp .....	16
6. Service .....	17
Batteries .....	17
General .....	17
Charging Batteries .....	17
Extending Battery Life .....	18
Storing Batteries .....	18
Holding Clamp Block .....	19
Friction Adjustment.....	19
Tracks .....	20
Alignment .....	20
Tension.....	20
Tension Adjustment .....	21
Removal and Replacement .....	21
Cleaning .....	22
Lubrication.....	23
7. Specifications .....	24
8. Trouble-Shooting .....	25
9. Clearances .....	26
10. Warranty.....	27

# GARAVENTA STAIR-TRAC

---

Congratulations on the purchase of your new Garaventa Stair-Trac.

Stair-Trac has been designed to provide years of use in assisting physically disabled people to overcome the barrier presented by stairs.

Before using the unit, please view the Operator Training video, and take a moment to read this manual so you will have a thorough understanding of the operation of Stair-Trac. Ensure **that Stair-Trac is operated only by someone who has been properly trained.**

Your Garaventa dealer is knowledgeable about the servicing requirements and safe operation of your Stair-Trac. If you have any questions consult your dealer, or contact Garaventa by phoning 604-594-0422, email [customerrelations@garaventa.ca](mailto:customerrelations@garaventa.ca), or by writing:

In Canada: Garaventa Accessibility  
7505-134A St.  
Surrey, BC  
V3W 7B3

In USA: Garaventa Accessibility  
PO Box 1769  
Blaine, WA  
98231-1769

Your Authorized Garaventa Dealer is:

Name: \_\_\_\_\_

Address \_\_\_\_\_  
\_\_\_\_\_

Telephone: \_\_\_\_\_

Record your Stair-Trac serial number in the space below, and refer to it whenever you call your Garaventa dealer about Stair-Trac.

Stair-Trac serial number: \_\_\_\_\_

# 1 Safety First!

---



This symbol is used throughout this manual to draw your attention to instructions that must be carefully followed to avoid possible dangers.

The following procedures are important to ensure the safe operation of Stair-Trac:

## **CHECK THE STAIRWAY**



Do not use Stair-Trac on curved or spiral stairs, irregular or insecure stairs or stairs with loose carpeting. Use extra caution on wet or slippery stairs.

## **CHECK THE STAIR ANGLE**



Do not use Stair-Trac on stairs that have not been checked by using the Stair Slope Indicator. Refer to page 5.

## **ENSURE THE WHEELCHAIR CAN BE PROPERLY ATTACHED**



Stair-Trac is not designed to be used with electric wheelchairs, scooters, carts and some models of sports chairs.

A chart on page 26 shows the sizes of wheelchairs that can be attached to Stair-Trac. Use Stair-Trac only with wheelchairs that conform to these ranges and clearances.

Some small wheelchairs may not be able to be pulled over the tracks due to their low underside clearances. These may be able to be attached by using the Wheelchair Attachment Ramp. Refer to page 16 for details.



### **DO NOT OVERLOAD**

Do not use Stair-Trac when the total load being carried (passenger and wheelchair) is more than 130 kg (285 lbs).



### **DOUBLE-CHECK ALL ATTACHMENTS BEFORE OPERATING**

Ensure the wheelchair is securely attached to the Wheelchair Support Handle. Refer to step 6 on page 7.

Ensure the Wheelchair Support Handle is locked on the Drive Frame. Refer to step 8 on page 7.

Ensure the Safety Belt is securely fastened, and that it passes *under* the arms of the passenger.



### **REMOVE ALL LOOSE ITEMS FROM WHEELCHAIR**

Do not operate Stair-Trac if loose objects are hanging outside of the wheelchair. Objects such as clothing or purses can be a safety hazard if they become caught on the stairway or in the Stair-Trac drive mechanism.

# 2 Terminology

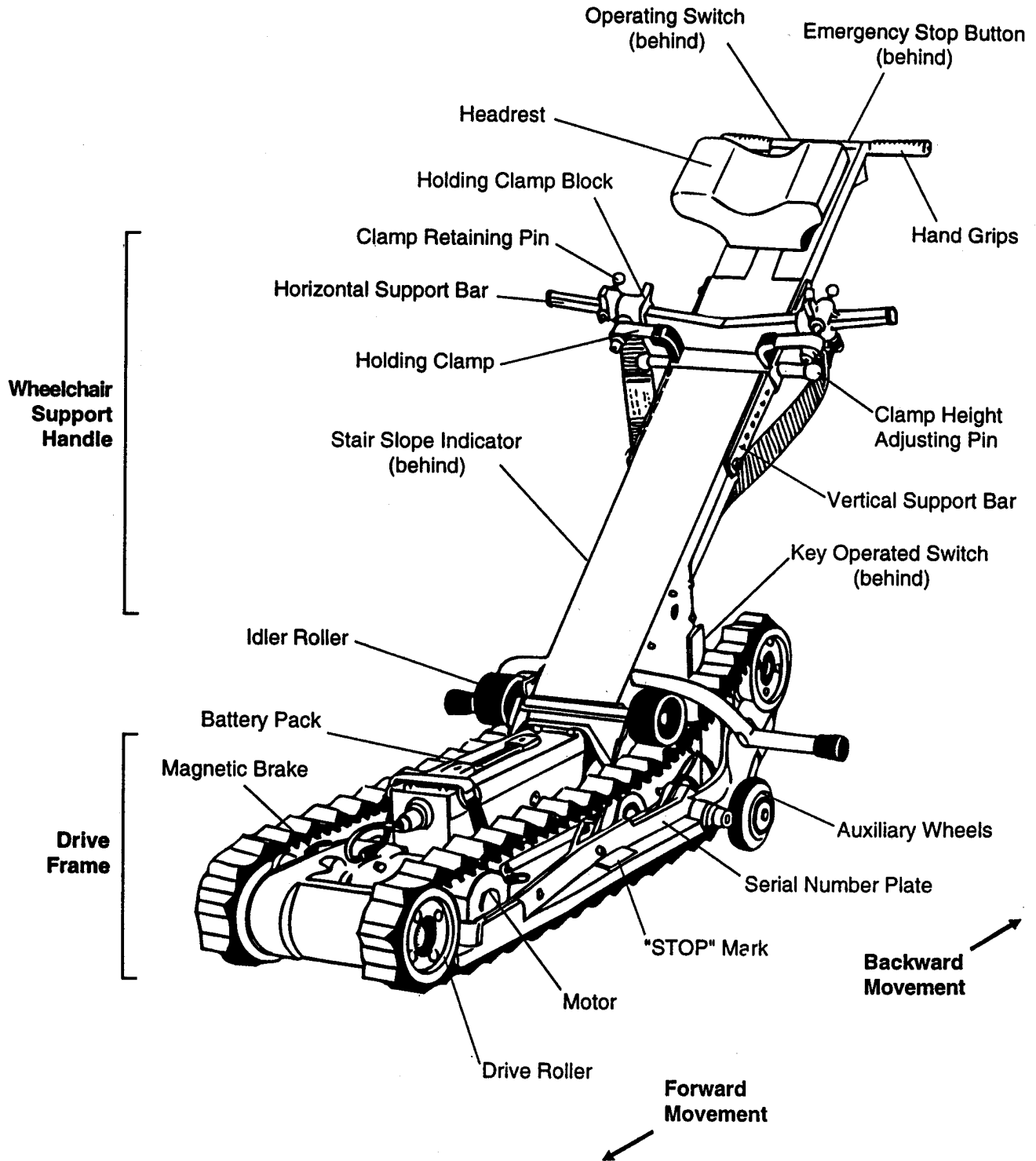

# 3 Operating Instructions

---

## INTRODUCTION

To ensure the safety of the passenger and operator, read these operating instructions carefully and view the Operator Training video. Practice sessions should be held on a regular basis (monthly is recommended) to maintain operator proficiency. In addition, building occupants for whom the Stair-Trac is provided should be familiar with and comfortable in using Stair-Trac.

### Note

The note symbol is used to direct you to a section in this manual containing additional operating tips.

---

## STAIR SLOPE INDICATOR

The Stair Slope Indicator is used to assess whether the angle of the stairway is within the optimum operating range of Stair-Trac. It should always be used.

Place the indicator across two stair noses and observe the colored area to which the arrow points.

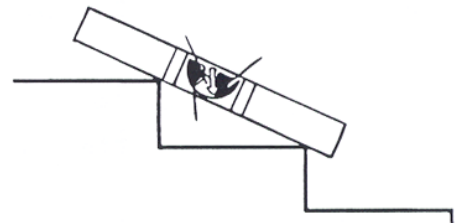

**Green:** Optimum operating range.

**Yellow:** Use added caution when operating.

**Red:** Stairway is too steep for safe operation. Do not use Stair-Trac.

## ATTACHING THE WHEELCHAIR SUPPORT HANDLE

1. Place the U-shaped brackets (at the bottom of the Wheelchair Support Handle) on the Mounting Bar. Lock in place with the retaining pins.

- 
2. Tilt the Support Handle backwards until the Locking Teeth latch under the Locking Bar
  3. To disconnect the Support Handle, pull the black Release Handle located just below the controls on the Support Handle. This lifts the Safety Bar. Then push the red Sliding Catch forward, raise the handle upright.

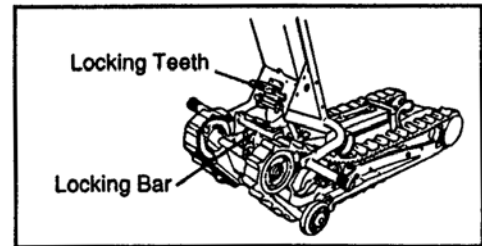

---

## ATTACHING WHEELCHAIRS

1. Refer to page 26 to determine the types and sizes of wheelchairs that can be attached to Stair-Trac.
2. Turn on the Key-Operated Switch located at the rear of the Drive Frame.

3. Back the wheelchair over the tracks, and center it (side to side) over the tracks.
4. Lift the Clamp Retaining Pins and open the Holding Clamps.

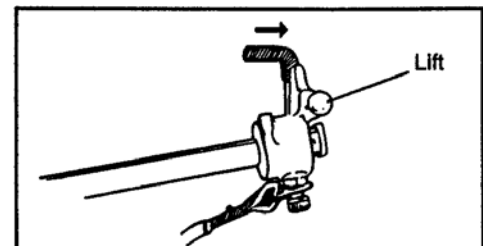
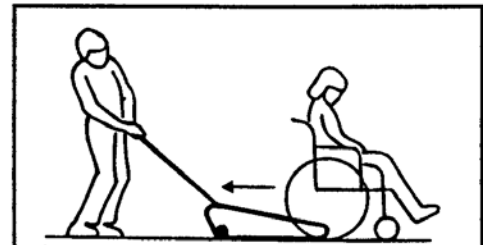



**Note**  
Page 13  
Item 2

5. Raise the Wheelchair Support Handle and position the Holding Clamp Blocks under the curve in the wheelchair handle. Ensure that the wheelchair handle rests in the hollow of the Clamp Block.

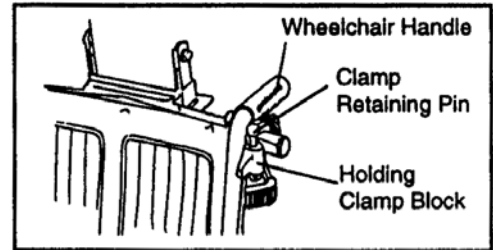

Adjust the Clamp Blocks side to side by sliding them on their mounting bars.

Adjust their height by pulling out the Clamp Height Adjusting Pins and raising or lowering the entire clamp assembly.

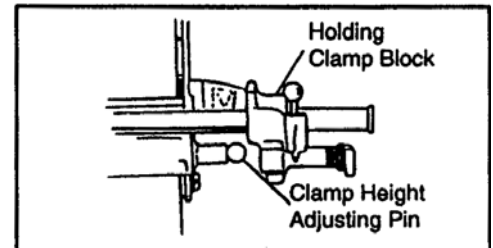

6. Close the Holding Clamps over the wheelchair handle, ensuring the Retaining Pin is on the outside of the Holding Clamp.

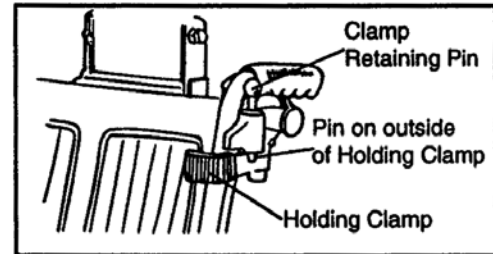

To ensure side-to-side stability, verify that the wheelchair is centered over the tracks (refer to step 3 above).



7. Fasten the Safety Belt securely, ensuring that it passes *under the arms* of the passenger. Adjust the Headrest.

8. Pull the Wheelchair Handle toward you until you hear a “click” sound as it latches in its operating position with the Locking Teeth latched under the Locking Bar.

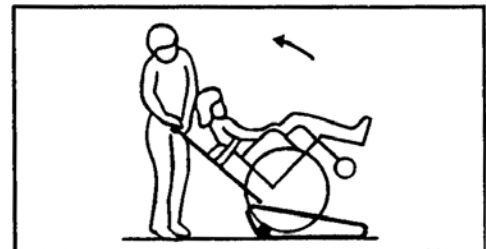



Since the weight of the passenger is tilted backwards at this point, always keep both hands on the Support Handle Hand Grips for stability. Do not leave the passenger unattended in this position.

---

## DETACHING WHEELCHAIRS

1. To lower the wheelchair to a horizontal position for detaching, firmly grip the Support Handle and press down slightly, but not enough to raise the front of Stair-Trac off the ground.

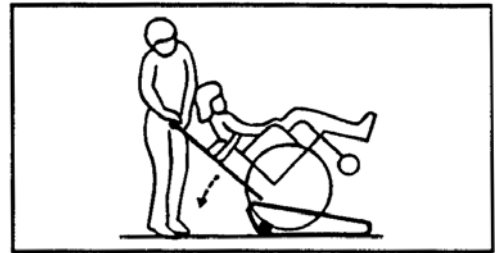

2. Pull the black Release Handle located just below the controls on the Support Handle. This lifts the Safety Bar. Then push the red Sliding Catch forward. Tip the Support Handle and wheelchair forward until the wheelchair touches the floor.

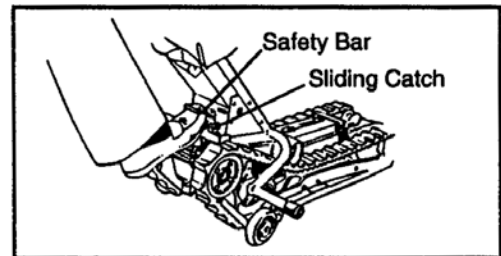

Do not release the locking mechanism while on a stairway.

3. Lift the handle upright, release the Safety Belt and Holding Clamps, and remove the wheelchair.

---

## HORIZONTAL TRAVEL

**Note**  
Page 14  
Item 3

To move Stair-Trac on flat surfaces, push down on the Support Handle until the tracks are raised from the surface, then push Stair-Trac along on its Auxiliary Wheels.



---

## EMERGENCY STOP BUTTON

In the unlikely event that the motor does not stop after the Operating Switch has been released, power to the motor can be disconnected by pressing and holding the Emergency Stop Button.

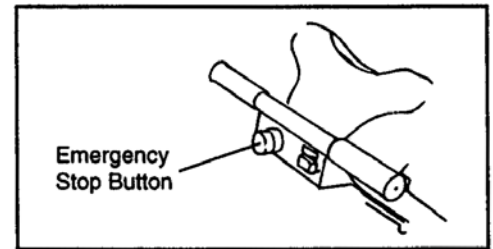

If it is necessary to use the Emergency Stop Button, ensure that Stair-Trac is examined by a qualified service person before it is used again.

---

## ASCENDING STAIRS

Practice ascending stairs without a passenger until you feel confident of your ability to use Stair-Trac. Practice ascending before you practice descending.

Note: Stair-Trac must travel “backward” when ascending stairs (Refer to Terminology on page 4).

1. Use the Slope Indicator to determine if Stair-Trac can be used on the stairway.

**Note**  
Page 14  
Item 4

2. Position Stair-Trac at the base of the stairs, at a right angle (90°) to the stairway with the passenger's back towards the stairs.

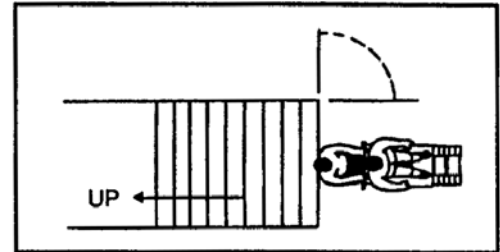

3. Keeping both hands on the Hand Grips, use your thumb to press the right side of the Operating Switch. Stair-Trac will begin climbing the stairs backwards.

**Note**  
Page 14  
Item 5

**Note**  
Page 14  
Item 6

4. As you ascend, ensure that Stair-Trac remains at a right angle to the stairs.

5. Stop Stair-Trac at the top of the stairs when the leading edge of the red "STOP" mark on the Drive Frame reaches the top stair nose.

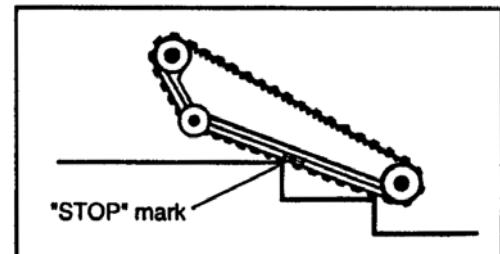

**Note**  
Page 15  
Item 7

6. Keeping both hands on the Hand Grips, slowly tilt Stair-Trac backward onto the landing.

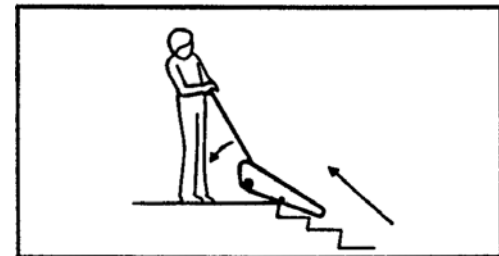

7. When Stair-Trac is level, press the right side of the Operating Switch, and back up until no part of Stair-Trac extends over the stairs.

8. Move Stair-Trac as required using the procedures described under "Horizontal Travel" (page 9).

## DESCENDING STAIRS

Practice descending stairs without a passenger until you feel confident of your ability to use Stair-Trac. Practice ascending before you practice descending.

Note: Stair-Trac must travel “forward” when descending stairs. (Refer to Terminology on page 4)

1. Use the Slope Indicator to determine if Stair-Trac can be used on stairway.

**Note**  
Page 14  
Item 4

2. Position Stair-Trac at the top of the stairs, at a right angle (90°) to the stairway with the passenger facing toward the stairs.

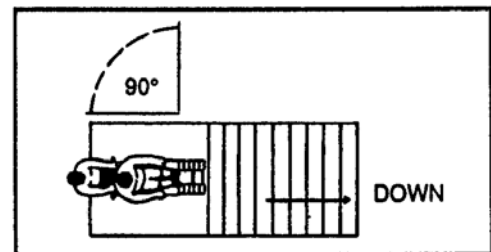

3. Keeping both hands on the hand grips, use your thumb to press the left side of the Operating Switch to move Stair-Trac forward. Release the Switch when the leading edge of the red “STOP” mark on the Drive Frame reaches the top of the stair nose.

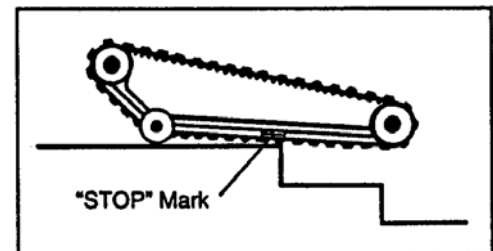

4. Keeping both hands on the Hand Grips, slowly tilt Stair-Trac forward until the tracks are resting on the stair noses, then press the left side of the Operating Switch to continue descending the stairs.



**Note**  
Page 14  
Item 7

---

5. As you descend, ensure that Stair-Trac remains at a right angle to the stairs.

6. On the lower landing, move Stair-Trac as required using the procedures described under “Horizontal Travel” (page 9).

---

## STORAGE

Stair-Trac occupies a minimal amount of space when stored as shown. Simply remove the Wheelchair Support Handle and place it upside down on the Drive Frame.

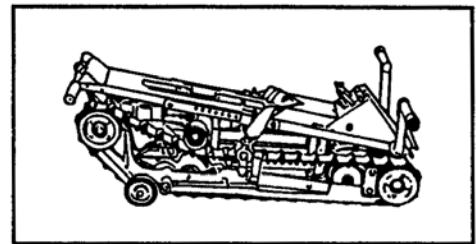

If Stair-Trac is to be stored for periods of 3 months or more, please follow the instructions under “Storing Batteries” (page 19).

# 4 Operating Tips

---

**Note**

Throughout this manual, the note symbol has been used to indicate areas where additional operating tips may be helpful. Following are these tips.

1. When attaching a small wheelchair, the chair's cross-frame may contact the tracks of Stair-Trac. The Wheelchair Attachment Ramp (optional item) can be used to raise the wheelchair slightly and facilitate attachment and detachment. Refer to "Wheelchair Attachment Ramp" on page 16.

2. Sometimes a wheelchair may be of such a height that with the clamp assembly under the curve of the handle you can almost, but not quite, lift the Clamp Assembly up to its next highest locked position. Since it is important to have as close a fit as possible, move the chair forward so the clamps are out from under the chair handles, and raise the Clamp Assembly up to its next highest locked position.

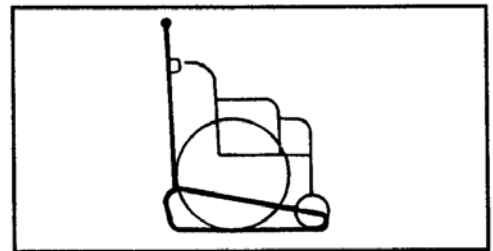

Ask the passenger to lean forward slightly and move the chair and handle forward until the Holding Clamp Blocks can be positioned under the curve in the handle.

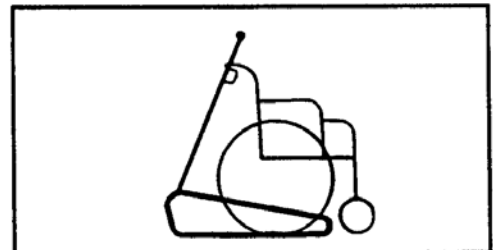

Now move the chair back and raise the handle upright at the same time. At this point the handle may even be supporting some of the chair's weight and the chair may be slightly off the ground.

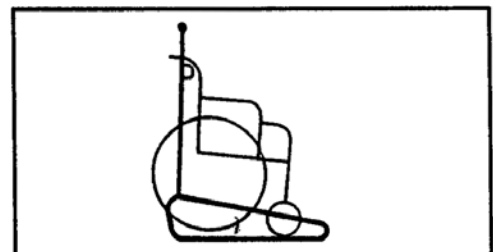

- 
3. Curbs or ridges higher than 50 mm (2 in) should be crossed by *backing* Stair-Trac over them, powered by the tracks. For ridges less than 50 mm (2 in) that Stair-Trac cannot easily rollover, simply lift upward on the handle and press the left side of the Operating Switch while moving forward over the obstacle. This will allow the tracks to pull Stair-Trac over the obstacle. Practice this maneuver first without a passenger.
  4. Operating Stair-Trac near the inner core of a stairway will keep the stairway clear for pedestrians, facilitate turning corners at the landings and provide your passenger with an added sense of comfort.
  5. A slight bump may occur as the Auxiliary Wheels rollover the first stair nose. This is normal. If the tracks slip and can't seem to push Stair-Trac past this point, simply lift up slightly on the handle while Stair-Trac is moving backwards. This will provide added traction between the tracks and the *floor*, allowing the Wheels to ride over the first stair nose.
  6. On some stairways Stair-Trac may "bump" slightly at one or two points during ascent or descent. This will not happen on all stairways, and occurs because the spacing between lugs on the tracks does not always coincide with the spacing between stair noses. When the top of a lug contacts a stair nose the Stair-Trac will shift slightly to position the base of the track on the stair nose, resulting in a slight "bump". There is no cause for alarm as Stair-Trac is perfectly stable and safe. You should inform your passenger that these "bumps" may occur so the passenger is not alarmed.
  7. The red "STOP" mark identifies the balance point of Stair-Trac. Under most conditions the mark is accurate; however, balance points will vary depending on the size of the wheelchair and the weight of the passenger. Always use caution when tilting Stair-Trac backward or forward at this point.



# 5 Optional Equipment

---

## WHEELCHAIR ATTACHMENT RAMP

On small wheelchairs the cross-frame of the chair may be too low to clear the tracks of the Stair-Trac, making it difficult to roll the wheelchair over the Drive Frame.

This problem can be eliminated by positioning the Wheelchair Attachment Ramp as shown and backing the wheelchair onto the Ramp.

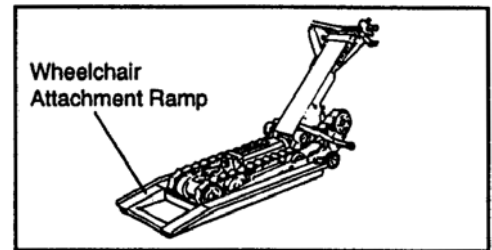

Attach the wheelchair as described under “Attaching Wheelchairs” on page 6, back the Stair-Trac away from the Ramp and proceed to the stairway. The Ramp can now be carried to the destination area.

On stairways where the Ramp is used repeatedly it may be beneficial to obtain two Ramps, locating one at each destination point.

To detach the wheelchair, move the Stair-Trac and passenger into position over the ramp, then lower the wheelchair and detach it as described under “Detaching Wheelchairs” on page 8.

---

## VEHICLE LOADING RAMP

Stair-Trac can easily be loaded into a van or a car trunk by using the Vehicle Loading Ramp.



The Ramp was designed to support the Drive Frame only, and is not capable of supporting Stair-Trac with a passenger.

1. Place the hook end of the Ramp over the edge of the trunk lid or van bumper.
2. Line up the front of the Drive Frame with the Ramp.

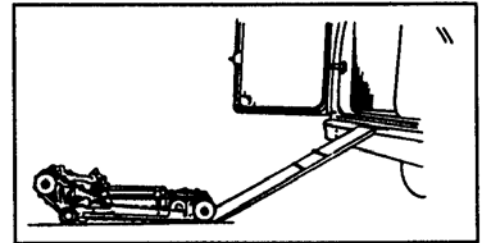

3. Remove the Wheelchair Support Handle.
4. Use the Operating Switch to make the Drive Frame crawl up the Ramp until it is balanced over the top edge of the Ramp.
5. *(a) Cars:*  
Tilt the front of the Drive Frame into the car trunk. When the tracks rest on the trunk floor, swing the back of the unit into the trunk, using the Operating Switch located on the Drive Frame to position Stair-Trac as required.
5. *(b) Vans or wagons:*  
Tilt the front of the Drive Frame onto the vehicle floor and use the Operating Switch located on the Drive Frame to move it into the vehicle.
6. Place the Wheelchair Support Handle upside down on the top of the Drive Frame. Refer to "Storage" (page 12).

# 6 Service

---

## BATTERIES

### General

Stair-Trac is powered by two 6-volt sealed batteries. These cells are spill-proof, maintenance-free and rechargeable. Power capacity under a full load while travelling upstairs is about 650 stairs or approximately 30 minutes on a full charge.

### Charging Batteries

The Battery Charger is used to charge the Stair-Trac batteries from the mainline (120 VAC) supply. Your Stair-Trac comes supplied with a 12 volt Charger designed for sealed batteries. It features the maximum recommended 4 amp charge rate and will automatically switch to a trickle-charge rate when the batteries are close to fully charged. At this point the Charger may be left connected indefinitely without damaging the batteries. The trickle-charge feature is important to prevent over-charging of the batteries and to help prolong their life.

Charging time will vary depending on battery use, but should not require more than eight hours.

**Caution:** Use of unauthorized chargers may cause damage to the batteries. If a substitute charger is used, ensure that it features a dual-mode automatic cut-off. Do not use a lead/acid battery charger.

To use the Battery Charger:

1. Disconnect the Stair-Trac cable from the battery pack.
2. Connect the Battery Charger cable to the battery pack.
3. Plug the Battery Charger into a 110 VAC power supply.

- 
4. The lamp will glow AMBER when the battery is charging and will change to GREEN when the battery is fully charged.

### **Extending Battery Life**

Battery life can be increased greatly by frequent charging. If a battery is totally discharged before being recharged it might be cycled (charged and discharged) only 180 times before it becomes unusable. If this same battery had been charged more often (for example at a 30% depth of discharge) it could be cycled over 1200 times. This is a life increase of more than six times.

If a battery has been stored for a long period and has become discharged (but still shows a voltage reading) it can be brought back to full charge by cycling it several times. To do this, charge the battery about ten hours, then use it for a few minutes but not long enough to totally discharge it. Then charge the battery again for about ten hours then use it for a few minutes. Cycle it this way about five times over a period of two weeks and the battery may recover. Whether or not it does will depend on the age of the battery and the care it has been given.

### **Storing Batteries**

Stored batteries should be fully charged every three months during the storage period.

Storage for a long period without recharging may cause batteries to become unable to be restored to capacity. This period will vary depending on what use the batteries have had before storage, their depth of charge at the time of storage, and the storage conditions.

Ensure the batteries are fully charged when storing.

---

Remove the battery pack from the equipment if it will not be used for more than six months.

To store the battery pack, disconnect it from the charger and store it in as dry and cool a location as possible.

**IMPORTANT:** The self-discharge rate increases dramatically as temperature increases. Batteries stored where temperatures are allowed to reach 100°F (38°C) will become totally discharged within five months. If kept at 50°F (10°C) they would have lost only 8% of their charge during the same period.

Batteries can be kept for storage in temperatures as low as -4°F (-20°C).

## HOLDING CLAMP BLOCK

### Friction Adjustment

To adjust the friction fit between the Holding Clamp Block and the Horizontal Support Bar, loosen the locking nut at the rear of the Block and use a 10 mm allen key to rotate the socket head bolt as required. Tighten the locking nut after the adjustment

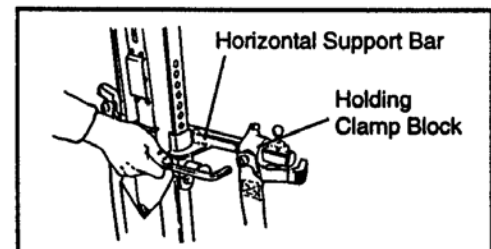

---

## TRACKS

### Alignment

It is important that tracks are aligned with each other to ensure that the track lugs on both tracks contact a stair nose at the same time.

Incorrectly aligned tracks will cause Stair-Trac to ascend stairways at an angle, reducing stability.



To check alignment, position a track so that a straight-edge placed across the Drive Frame lines up with a specific point on the track, for example the beginning of a lug. Check the opposite track to ensure that the same relative point on the track lines up with the same point on the straight edge.

To adjust alignment, reposition one of the tracks on the cogs of the Drive Wheel so that the alignment indicators on both tracks are exactly opposite each other. The alignment indicators are the numbers "87.5 x 2" in raised print on both sides of one track lug. Note that you may have to try re-positioning the track a few times to find a location that provides correct alignment.

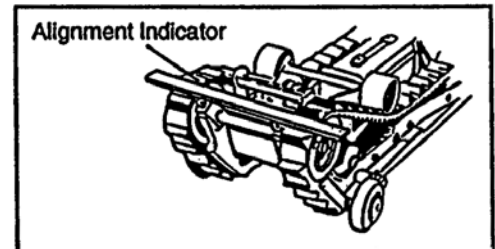

After adjusting track alignment, be sure to check track tension.

### Tension

Track tension should be very low and a visible amount of slack should be seen in the tracks.

To check tension, position the tracks until the Idler Rollers rest between lugs on the tracks.

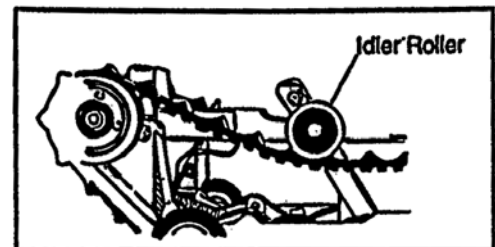

---

At a point halfway between the Idler Roller and the Drive Roller, press down firmly with your hand. At the closest point the track cogs should be 70mm  $\pm$  3mm (2 3/4 in  $\pm$  1/8 in) away from the part of the Drive Frame. You'll note that tracks will touch the motor housing, but is taken into consideration in the measurements. Check and adjust each track to obtain this measurement.

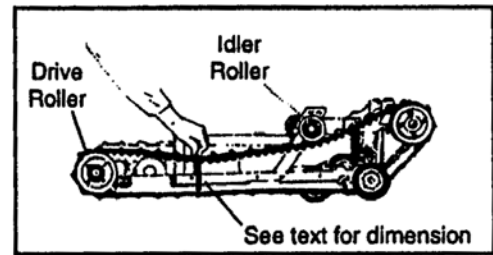

flat  
the  
this

## Tension Adjustment

To adjust tension use two 19 mm wrenches to slightly loosen the rear axle. Then use a 17 mm wrench and a 5 mm allen key to loosen the Tension Locking Nuts and turn the Tension Adjusting Screw; clockwise to increase tension, or counter-clockwise to decrease tension.

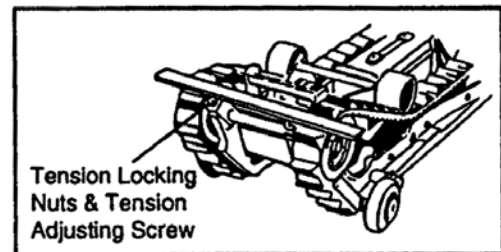

When decreasing tension, after turning the Adjusting Screw, press down on the tracks to remove any slack in them and to relocate the rear axle.

## Removal and Replacement

Wear on Stair-Trac's tracks should be minimal and track life will be determined by natural environmental conditions. The tracks contain hundreds of steel wires to eliminate any possibility of stretching, and are covered by a thick coat of rubber. They are very durable, but should be replaced if they are cut or cracked in any way, or show signs of deterioration.

---

To remove a track, remove the four screws that attach the Wheel Flange to the Wheel, then remove the Flange. Use chalk or a felt pen to mark the position of the track relative to its toothed wheel, then slide the track off the wheel.

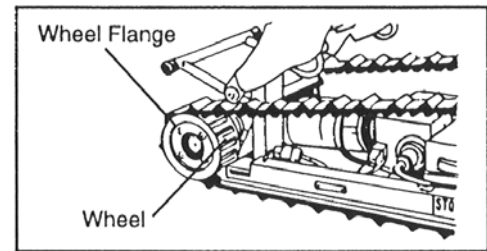

When re-installing the track, ensure the chalk mark you've made on the track lines up with the chalk mark on the wheel. Check track alignment as outlined at the beginning of this chapter.

## Cleaning

To ensure maximum adhesion to stair surfaces, tracks must be kept clean and free of oil and dirt.

In some cases wax applied to floor surfaces can be spread to the stairs by pedestrian traffic. Over a period of time this wax will build up on the tracks, causing poor traction between the tracks and the stairs, and resulting in Stair-Trac slipping on the stairs.

Tracks can be cleaned using a mild detergent. Wax build-up can be removed with household wax-removing products. The need for cleaning the tracks will depend on the frequency that Stair-Trac is used, but we recommend that tracks be cleaned at least twice yearly.

Similarly, the noses of the stairs that Stair-Trac routinely ascends or descends should be cleaned regularly.



---

## LUBRICATION

Bearings used in the motor, gearbox and drive wheels are sealed and require no lubrication. All other moving parts except for the Locking Teeth should be *lightly* oiled with a medium weight oil such as automotive type SAE 30.

Use care when applying oil as excessive oil could drip on the tracks, causing a safety hazard on stairs. The Locking Teeth should always have a thin film of lightweight grease at the points shown.

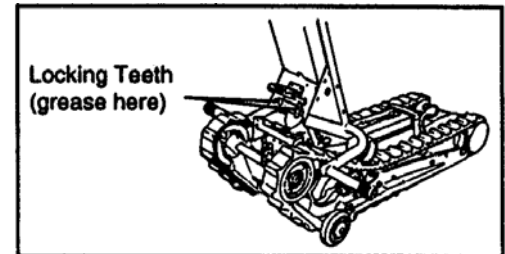

# 7 Specifications

---

Load Capacity .....	130 kg/285 lbs
Power capacity (loaded) .....	650 stairs
Speed:	
Up stairs .....	6.45 m(21.2 ft)/min
Down stairs .....	8.81 m(28.9 ft)/min
Motor .....	12 V dc
Batteries .....	2 x 6V, 20 AH
Charge rate (max) .....	4 Amps
Maximum stair angle .....	35 °
Dimensions:	
Height .....	922 mm/36.3 in
Length .....	1468 mm/57.8 in
Width .....	636 mm/25 in
Weight:	
Drive Frame .....	31 kg/68 lbs
Support Handle .....	14 kg/31lbs
Battery .....	8.5 kg/19 lbs
Total .....	53.5 kg/118 lbs

# 8 Trouble Shooting

---

If the remedies shown below do not resolve your operating problem, contact your authorized Stair-Trac dealer for service.

<b>SYMPTOM</b>	<b>POSSIBLE CAUSE</b>	<b>REMEDY</b>
Motor won't operate	Key not turned on	Refer to page 4
	Battery not connected	Connect battery
	Battery low	Recharge battery
Charger won't recharge battery	Poor connection between charger and battery	Check and tighten
	Charger defective	Contact dealer
	Batteries worn out or defective	Contact dealer
Goes up or down stairs at an angle	Tracks out of alignment	Refer to page 20, or contact dealer
Tracks slip on stairs	Tracks out of alignment	Refer to page 20, or contact dealer
	Tracks dirty	Refer to page 23
	Wheelchair anti-tip wheels touching auxiliary wheels	Remove anti-tip wheels
	Wheelchair mounted too low, and wheels touch stair noses	Mount wheelchair higher
	Normal operation	Refer to page 14, item 6
Tracks slip on first step	Normal operation	Refer to page 14, item 5

# 9 Clearances

To determine if a wheelchair can be attached to Stair-Trac, measure the height and width of the wheelchair handles and measure the clearances under the wheelchair. If they fall within the limits shown below and no special modifications have been made which might hinder its attachment, the chair should be able to be attached to Stair-Trac. Note that by using a Wheelchair Attachment Ramp (refer to page 16) the wheelchair is raised by 63 mm (2 1/2 in). This increased clearance enables some small wheelchairs to be attached to Stair-Trac.

Stair-Trac can be used only with wheelchairs that are fitted with push handles, and the push handles must be securely fastened to the wheelchair frames.

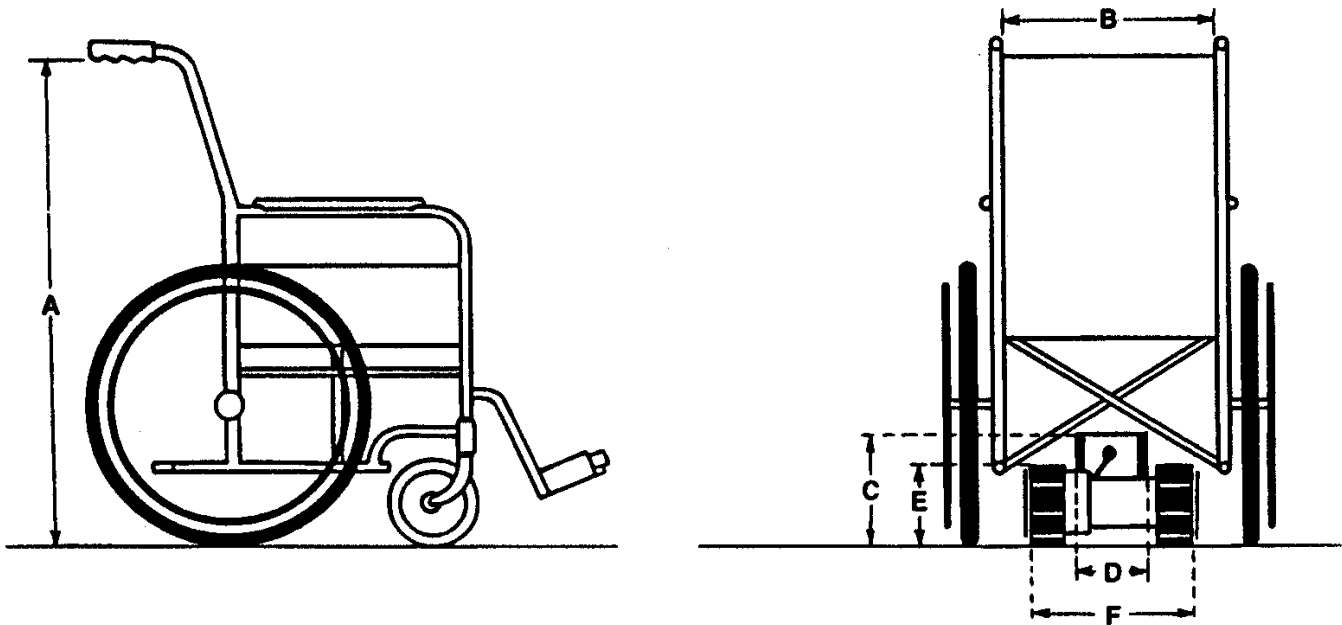

- A. Height from floor to underside of curve in wheelchair handle
  - Minimum .....694 mm (27.25 in)
  - Maximum ..... 970mm (38 in)
- B. Width between inside of wheelchair handles
  - Minimum ..... 228 mm (9 in)
  - Maximum .....470 mm (18.5 in)
- C. Height of top of battery pack .....187 mm (7.4 in)
- D. Width of top of battery pack .....114 mm (4.5 in)
- E. Height of track .....159 mm (6.25 in)
- F. Width of track .....295 mm (11.6 in)

# 10 Warranty

---

Garaventa warrants Stair-Trac to be free from defects in materials and workmanship under normal use and service for a period of one year from the date of purchase, reasonable wear and tear excluded. Proof of date of purchase is required to determine warranty period.

This Warranty does not extend to any Stair-Trac unit which has been subjected to misuse, neglect, accident, modifications, or damage from fire, lightning, or water, or used in violation of the instructions furnished, nor units repaired or altered by other than an authorized dealer .

Garaventa's liability hereunder is limited to repair and replacement only. Transportation and labor charges are not covered. Garaventa accepts no liability for any loss or damage resulting from the use or misuse of Stair-Trac, whether such loss or damage is direct, indirect or consequential. All other express or implied warranties, statutory or otherwise, are excluded.

## **WARRANTY REGISTRATION**

A postage-paid warranty registration card is enclosed with this Owner's Manual. Complete and return the card within ten days of your Stair-Trac purchase.